

ASME B31.1-2016
(Revision of ASME B31.1-2014)

Power Piping

ASME Code for Pressure Piping, B31

AN INTERNATIONAL PIPING CODE®



**The American Society of
Mechanical Engineers**

ASME B31.1-2016
(Revision of ASME B31.1-2014)

Power Piping

ASME Code for Pressure Piping, B31

AN INTERNATIONAL PIPING CODE®



**The American Society of
Mechanical Engineers**

Two Park Avenue • New York, NY • 10016 USA

Date of Issuance: June 30, 2016

The next edition of this Code is scheduled for publication in 2018. This Code will become effective 6 months after the Date of Issuance.

ASME issues written replies to inquiries concerning interpretations of technical aspects of this Code. Interpretations are published under <http://go.asme.org/Interpretations>. Periodically certain actions of the ASME B31 Committees may be published as Cases. Cases are published on the ASME Web site under the Committee Pages at <http://go.asme.org/B31committee> as they are issued.

Errata to codes and standards may be posted on the ASME Web site under the Committee Pages to provide corrections to incorrectly published items, or to correct typographical or grammatical errors in codes and standards. Such errata shall be used on the date posted.

The B31 Committee Pages can be found at <http://go.asme.org/B31committee>. The associated B31 Committee Pages for each code and standard can be accessed from this main page. There is an option available to automatically receive an e-mail notification when errata are posted to a particular code or standard. This option can be found on the appropriate Committee Page after selecting “Errata” in the “Publication Information” section.

ASME is the registered trademark of The American Society of Mechanical Engineers.

This international code or standard was developed under procedures accredited as meeting the criteria for American National Standards and it is an American National Standard. The Standards Committee that approved the code or standard was balanced to assure that individuals from competent and concerned interests have had an opportunity to participate. The proposed code or standard was made available for public review and comment that provides an opportunity for additional public input from industry, academia, regulatory agencies, and the public-at-large.

ASME does not “approve,” “rate,” or “endorse” any item, construction, proprietary device, or activity.

ASME does not take any position with respect to the validity of any patent rights asserted in connection with any items mentioned in this document, and does not undertake to insure anyone utilizing a standard against liability for infringement of any applicable letters patent, nor assume any such liability. Users of a code or standard are expressly advised that determination of the validity of any such patent rights, and the risk of infringement of such rights, is entirely their own responsibility.

Participation by federal agency representative(s) or person(s) affiliated with industry is not to be interpreted as government or industry endorsement of this code or standard.

ASME accepts responsibility for only those interpretations of this document issued in accordance with the established ASME procedures and policies, which precludes the issuance of interpretations by individuals.

No part of this document may be reproduced in any form,
in an electronic retrieval system or otherwise,
without the prior written permission of the publisher.

The American Society of Mechanical Engineers
Two Park Avenue, New York, NY 10016-5990

Copyright © 2016 by
THE AMERICAN SOCIETY OF MECHANICAL ENGINEERS
All rights reserved
Printed in U.S.A.

CONTENTS

Foreword	vii	
Committee Roster	viii	
Introduction	xii	
Summary of Changes	xiv	
Chapter I	Scope and Definitions	1
100	General	1
Chapter II	Design	14
Part 1	Conditions and Criteria	14
101	Design Conditions	14
102	Design Criteria	15
Part 2	Pressure Design of Piping Components	21
103	Criteria for Pressure Design of Piping Components	21
104	Pressure Design of Components	21
Part 3	Selection and Limitations of Piping Components	36
105	Pipe	36
106	Fittings, Bends, and Intersections	36
107	Valves	37
108	Pipe Flanges, Blanks, Flange Facings, Gaskets, and Bolting	38
Part 4	Selection and Limitations of Piping Joints	39
110	Piping Joints	39
111	Welded Joints	39
112	Flanged Joints	40
113	Expanded or Rolled Joints	40
114	Threaded Joints	40
115	Flared, Flareless, and Compression Joints, and Unions	45
116	Bell End Joints	45
117	Brazed and Soldered Joints	45
118	Sleeve Coupled and Other Proprietary Joints	46
Part 5	Expansion, Flexibility, and Pipe-Supporting Element	46
119	Expansion and Flexibility	46
120	Loads on Pipe-Supporting Elements	49
121	Design of Pipe-Supporting Elements	49
Part 6	Systems	53
122	Design Requirements Pertaining to Specific Piping Systems	53
Chapter III	Materials	68
123	General Requirements	68
124	Limitations on Materials	69
125	Creep Strength Enhanced Ferritic Materials	71
Chapter IV	Dimensional Requirements	73
126	Material Specifications and Standards for Standard and Nonstandard Piping Components	73
Chapter V	Fabrication, Assembly, and Erection	81
127	Welding	81
128	Brazing and Soldering	92
129	Bending and Forming	94
130	Requirements for Fabricating and Attaching Pipe Supports	97
131	Welding Preheat	97

132	Postweld Heat Treatment	97
133	Stamping	104
135	Assembly	104
Chapter VI	Inspection, Examination, and Testing	106
136	Inspection and Examination	106
137	Pressure Tests	110
Chapter VII	Operation and Maintenance	114
138	General	114
139	Operation and Maintenance Procedures	114
140	Condition Assessment of CPS	114
141	CPS Records	115
142	Piping and Pipe-Support Maintenance Program and Personnel Requirements	116
144	CPS Walkdowns	116
145	Material Degradation Mechanisms	116
146	Dynamic Loading	116
Figures		
100.1.2(A.1)	Code Jurisdictional Limits for Piping — An Example of Forced Flow Steam Generators With No Fixed Steam and Water Line	2
100.1.2(A.2)	Code Jurisdictional Limits for Piping — An Example of Steam Separator Type Forced Flow Steam Generators With No Fixed Steam and Water Line	3
100.1.2(B.1)	Code Jurisdictional Limits for Piping — Drum-Type Boilers	4
100.1.2(B.2)	Code Jurisdictional Limits for Piping — Isolable Economizers Located in Feedwater Piping and Isolable Superheaters in Main Steam Piping (Boiler Pressure Relief Valves, Blowoff, and Miscellaneous Piping for Boiler Proper Not Shown for Clarity)	5
100.1.2(B.3)	Code Jurisdictional Limits for Piping — Nonintegral Separately Fired Superheaters	6
100.1.2(C)	Code Jurisdictional Limits for Piping — Spray-Type Desuperheater	7
102.4.5	Nomenclature for Pipe Bends	19
104.3.1(D)	Reinforcement of Branch Connections	27
104.3.1(G)	Reinforced Extruded Outlets	30
104.5.3	Types of Permanent Blanks	34
104.8.4	Cross Section Resultant Moment Loading	35
122.1.7(C)	Typical Globe Valves	57
122.4	Desuperheater Schematic Arrangement	62
127.3	Butt Welding of Piping Components With Internal Misalignment	82
127.4.2	Welding End Transition — Maximum Envelope	83
127.4.4(A)	Fillet Weld Size	86
127.4.4(B)	Welding Details for Slip-On and Socket-Welding Flanges; Some Acceptable Types of Flange Attachment Welds	87
127.4.4(C)	Minimum Welding Dimensions Required for Socket Welding Components Other Than Flanges	87
127.4.8(A)	Typical Welded Branch Connection Without Additional Reinforcement	87
127.4.8(B)	Typical Welded Branch Connection With Additional Reinforcement	87
127.4.8(C)	Typical Welded Angular Branch Connection Without Additional Reinforcement	87
127.4.8(D)	Some Acceptable Types of Welded Branch Attachment Details Showing Minimum Acceptable Welds	88
127.4.8(E)	Some Acceptable Details for Integrally Reinforced Outlet Fittings	89
127.4.8(F)	Typical Full Penetration Weld Branch Connections for NPS 3 (DN 80) and Smaller Half Couplings or Adapters	90

127.4.8(G)	Typical Partial Penetration Weld Branch Connection for NPS 2 (DN 50) and Smaller Fittings	91
135.5.3	Typical Threaded Joints Using Straight Threads	105
Tables		
102.4.3	Longitudinal Weld Joint Efficiency Factors	18
102.4.5	Bend Thinning Allowance	19
102.4.6(B.1.1)	Maximum Severity Level for Casting Thickness 4½ in. (114 mm) or Less	20
102.4.6(B.2.2)	Maximum Severity Level for Casting Thickness Greater Than 4½ in. (114 mm)	21
102.4.7	Weld Strength Reduction Factors to Be Applied When Calculating the Minimum Wall Thickness or Allowable Design Pressure of Components Fabricated With a Longitudinal Seam Fusion Weld	22
104.1.2(A)	Values of y	24
112	Piping Flange Bolting, Facing, and Gasket Requirements	41
114.2.1	Threaded Joints Limitations	45
121.5	Suggested Steel Pipe Support Spacing	50
121.7.2(A)	Carrying Capacity of Threaded ASTM A36, A575, and A576 Hot-Rolled Carbon Steel	52
122.2	Design Pressure for Blowoff/Blowdown Piping Downstream of BEP Valves	58
122.8.2(B)	Minimum Wall Thickness Requirements for Toxic Fluid Piping	65
126.1	Specifications and Standards	74
127.4.2	Reinforcement of Girth and Longitudinal Butt Welds	85
129.3.1	Approximate Lower Critical Temperatures	94
129.3.3.1	Post Cold-Forming Strain Limits and Heat-Treatment Requirements	95
129.3.4.1	Post Cold-Forming Strain Limits and Heat-Treatment Requirements	96
131.4.1	Preheat Temperatures	98
132	Postweld Heat Treatment	99
132.1	Alternate Postweld Heat Treatment Requirements for Carbon and Low Alloy Steels, P-Nos. 1 and 3	100
132.1.3	Postweld Heat Treatment of P36/F36	100
132.2	Exemptions to Mandatory Postweld Heat Treatment	101
136.4	Mandatory Minimum Nondestructive Examinations for Pressure Welds or Welds to Pressure-Retaining Components	108
136.4.1	Weld Imperfections Indicated by Various Types of Examination	109
Mandatory Appendices		
A	Allowable Stress Tables	117
	Table A-1, Carbon Steel	118
	Table A-2, Low and Intermediate Alloy Steel	130
	Table A-3, Stainless Steels	140
	Table A-4, Nickel and High Nickel Alloys	170
	Table A-5, Cast Iron	182
	Table A-6, Copper and Copper Alloys	184
	Table A-7, Aluminum and Aluminum Alloys	188
	Table A-8, Temperatures 1,200°F and Above	196
	Table A-9, Titanium and Titanium Alloys	202
	Table A-10, Bolts, Nuts, and Studs	206
B	Thermal Expansion Data	211
C	Moduli of Elasticity	220
D	Flexibility and Stress Intensification Factors	226
F	Referenced Standards	233
G	Nomenclature	237
H	Preparation of Technical Inquiries	244
J	Quality Control Requirements for Boiler External Piping (BEP)	245
N	Rules for Nonmetallic Piping and Piping Lined With Nonmetals	247

Nonmandatory Appendices		
II	Rules for the Design of Safety Valve Installations	275
IV	Corrosion Control for ASME B31.1 Power Piping Systems	296
V	Recommended Practice for Operation, Maintenance, and Modification of Power Piping Systems	300
VI	Approval of New Materials	313
VII	Procedures for the Design of Restrained Underground Piping	315
VIII	Guidelines for Determining If Low-Temperature Service Requirements Apply	326
Index	335

FOREWORD

The general philosophy underlying this Power Piping Code is to parallel those provisions of Section I, Power Boilers, of the ASME Boiler and Pressure Vessel Code, as they can be applied to power piping systems. The Allowable Stress Values for power piping are generally consistent with those assigned for power boilers. This Code is more conservative than some other piping codes, reflecting the need for long service life and maximum reliability in power plant installations.

The Power Piping Code as currently written does not differentiate among the design, fabrication, and erection requirements for critical and noncritical piping systems, except for certain stress calculations and mandatory nondestructive tests of welds for heavy wall, high temperature applications. The problem involved is to try to reach agreement on how to evaluate criticality, and to avoid the inference that noncritical systems do not require competence in design, fabrication, and erection. Someday such levels of quality may be definable, so that the need for the many different piping codes will be overcome.

There are many instances where the Code serves to warn a designer, fabricator, or erector against possible pitfalls; but the Code is not a handbook, and cannot substitute for education, experience, and sound engineering judgment.

Nonmandatory Appendices are included in the Code. Each contains information on a specific subject, and is maintained current with the Code. Although written in mandatory language, these Appendices are offered for application at the user's discretion.

The Code never intentionally puts a ceiling limit on conservatism. A designer is free to specify more rigid requirements as he feels they may be justified. Conversely, a designer who is capable of a more rigorous analysis than is specified in the Code may justify a less conservative design, and still satisfy the basic intent of the Code.

The Power Piping Committee strives to keep abreast of the current technological improvements in new materials, fabrication practices, and testing techniques; and endeavors to keep the Code updated to permit the use of acceptable new developments.

ASME B31 COMMITTEE

Code for Pressure Piping

(The following is the roster of the Committee at the time of approval of this Code.)

STANDARDS COMMITTEE OFFICERS

J. E. Meyer, *Chair*
J. W. Frey, *Vice Chair*
G. Eisenberg, *Secretary*

STANDARDS COMMITTEE PERSONNEL

R. J. T. Appleby	W. J. Mauro , American Electric Power
C. Becht IV , Becht Engineering Co.	J. E. Meyer , Louis Perry Group
K. C. Bodenhamer , Willbros Professional Services	T. Monday , Team Industries, Inc.
R. Bojarczuk , ExxonMobil Research and Engineering Co.	M. L. Nayyar , NICE
C. J. Campbell , Air Liquide	G. R. Petru , Acapella Engineering Services, LLC
J. S. Chin , TransCanada Pipeline U.S.	D. W. Raho , CCM 2000
D. D. Christian , Victaulic	R. Reamey , Turner Industries Group, LLC
P. Deubler , Fronex Power Systems, LLC	E. Rinaca
G. Eisenberg , The American Society of Mechanical Engineers	M. J. Rosenfeld , Kiefner/Applus — RTD
C. Eskridge, Jr. , Jacobs Engineering	J. T. Schmitz , Southwest Gas Corp.
D. J. Fetzner , BP Exploration Alaska, Inc.	S. K. Sinha , Lucius Pitkin, Inc.
P. D. Flenner , Flenner Engineering Services	W. Sperko , Sperko Engineering Services, Inc.
J. W. Frey , Stress Engineering Services, Inc.	J. Swezy, Jr. , Boiler Code Tech, LLC
D. Friksen , Becht Engineering Co.	F. W. Tatar , FM Global
R. A. Grichuk , Fluor Enterprises, Inc.	K. A. Vilminot , Black & Veatch
R. W. Haupt , Pressure Piping Engineering Associates, Inc.	L. E. Hayden, Jr. , <i>Ex-Officio</i> , Consultant
G. Jolly , Flowserve/Gestra, USA	A. J. Livingston , <i>Ex-Officio</i> , Kinder Morgan
	J. S. Willis , <i>Ex-Officio</i> , Page Southerland Page, Inc.

B31.1 POWER PIPING SECTION COMMITTEE

W. J. Mauro , <i>Chair</i> , American Electric Power	C. Henley
K. A. Vilminot , <i>Vice Chair</i> , Black & Veatch	B. P. Holbrook , Babcock Power, Inc.
C. E. O'Brien , <i>Secretary</i> , The American Society of Mechanical Engineers	M. W. Johnson , NRG Energy
D. D. Christian , Victaulic	R. Kennedy , DTE Energy
M. J. Cohn , Intertek AIM	D. J. Leininger , WorleyParsons
R. Corbit	W. M. Lundy , U.S. Coast Guard
D. Creates , Ontario Power Generation, Inc.	L. C. McDonald
P. M. Davis , Amec Foster Wheeler	T. Monday , Team Industries, Inc.
P. Deubler , Fronex Power Systems, LLC	M. L. Nayyar , NICE
A. S. Drake , Constellation Energy Group	J. W. Power , GE Power
M. Engelkemier , Stanley Consultants, Inc.	D. W. Raho , CCM 2000
S. Findlan , CB&I	K. I. Rapkin , FPL
P. D. Flenner , Flenner Engineering Services	R. Reamey , Turner Industries Group, LLC
J. W. Frey , Stress Engineering Services, Inc.	E. Rinaca
S. Gingrich , AECOM	J. P. Scott , Dominion
J. W. Goodwin , Southern Co.	J. J. Sekely , Welding Services, Inc.
J. Hainsworth	H. R. Simpson , PM&C Engineering
T. E. Hansen , American Electric Power	S. K. Sinha , Lucius Pitkin, Inc.
R. W. Haupt , Pressure Piping Engineering Associates, Inc.	A. L. Watkins , First Energy Corp.
	R. B. Wilson , R. B. Wilson & Associates Ltd.
	E. C. Goodling, Jr. , <i>Contributing Member</i>

B31.1 SUBGROUP ON DESIGN

M. Engelkemier, *Chair*, Stanley Consultants, Inc.
R. Kennedy, *Secretary*, DTE Energy
M. J. Barcelona, Riley Power, Inc.
S. M. Byda
N. P. Circolone, Sargent & Lundy, LLC
D. Creates, Ontario Power Generation, Inc.
S. A. Davis, WorleyParsons
A. S. Drake, Constellation Energy Group
J. W. Goodwin, Southern Co.
R. W. Haupt, Pressure Piping Engineering Associates, Inc.
B. P. Holbrook, Babcock Power, Inc.

M. W. Johnson, NRG Energy
W. M. Lundy, U.S. Coast Guard
J. McCormick, Commonwealth Associates, Inc.
K. I. Rapkin, FPL
P. E. Sandage
T. Sato, Japan Power Engineering and Inspection Corp.
D. B. Selman, Middough, Inc.
K. A. Vilminot, Black & Veatch
A. L. Watkins, First Energy Corp.
R. B. Wilson, R. B. Wilson & Associates Ltd.
A. D. Nance, *Contributing Member*, Senior Consultant

B31.1 SUBGROUP ON FABRICATION AND EXAMINATION

R. Reamey, *Chair*, Turner Industries Group, LLC
B. M. Boseo, Graycor Industrial Constructors, Inc.
R. Corbit
R. D. Couch, Electric Power Research Institute
P. M. Davis, Amec Foster Wheeler
S. Findlan, CB&I
P. D. Flenner, Flenner Engineering Services
J. W. Frey, Stress Engineering Services, Inc.
S. Gingrich, AECOM

W. J. Goedde, High Energy Piping SME
J. Hainsworth
T. E. Hansen, American Electric Power
K. G. Kofford, Idaho National Laboratory
D. J. Leininger, WorleyParsons
R. L. Miletti, Babcock & Wilcox Construction Co.
T. Monday, Team Industries, Inc.
J. J. Sekely, Welding Services, Inc.
C. R. Zimpel, Bendtec, Inc.
E. F. Gerwin, *Honorary Member*

B31.1 SUBGROUP ON GENERAL REQUIREMENTS

J. W. Power, *Chair*, GE Power
D. D. Christian, Victaulic
W. J. Mauro, American Electric Power
R. Thein, St. Paul Pipefitters Joint Apprenticeship Training Committee

M. Treat, Associated Electric Cooperative, Inc.
G. B. Trinker, Victaulic Co.

B31.1 SUBGROUP ON MATERIALS

D. W. Raho, *Chair*, CCM 2000
P. Deubler, Fronex Power Systems, LLC
C. Henley
S. L. McCracken, Electric Power Research Institute – WRTC

L. C. McDonald
M. L. Nayyar, NICE
R. G. Young, American Electric Power

B31.1 SUBGROUP ON OPERATION AND MAINTENANCE

J. P. Scott, *Chair*, Dominion
P. M. Davis, *Secretary*, Amec Foster Wheeler
M. J. Barcelona, Riley Power, Inc.
M. J. Cohn, Intertek AIM
D. Creates, Ontario Power Generation, Inc.
S. DuChes, Bechtel Power
M. Engelkemier, Stanley Consultants, Inc.
P. D. Flenner, Flenner Engineering Services
J. W. Frey, Stress Engineering Services, Inc.
W. J. Goedde, High Energy Piping SME
J. W. Goodwin, Southern Co.
T. E. Hansen, American Electric Power

R. W. Haupt, Pressure Piping Engineering Associates, Inc.
B. P. Holbrook, Babcock Power, Inc.
M. W. Johnson, NRG Energy
R. Kennedy, DTE Energy
W. J. Mauro, American Electric Power
L. C. McDonald
M. L. Nayyar, NICE
K. I. Rapkin, FPL
R. Reamey, Turner Industries Group, LLC
E. Rinaca
L. Vetter, Sargent & Lundy Engineers
E. C. Goodling, Jr., *Contributing Member*

B31.1 SUBGROUP ON SPECIAL ASSIGNMENTS

S. K. Sinha, *Chair*, Lucius Pitkin, Inc.
J. P. Scott, *Secretary*, Dominion
M. J. Cohn, Intertek AIM
S. DuChez, Bechtel Power
A. A. Hassan, Power Generation Engineering and Services Co.

E. Rinaca
H. R. Simpson, PM&C Engineering
L. Vetter, Sargent & Lundy Engineers
D. A. Yoder, WorleyParsons
E. C. Goodling, Jr., *Contributing Member*

B31 EXECUTIVE COMMITTEE

J. W. Frey, *Chair*, Stress Engineering Services, Inc.
G. Antaki, Becht Engineering Co., Inc.
R. J. T. Appleby
D. D. Christian, Victaulic
D. Frikken, Becht Engineering Co.
R. A. Grichuk, Fluor Enterprises, Inc.
L. E. Hayden, Jr., Consultant
C. E. Kolovich, Kiefner

H. Kutz, Johnson Controls Corp.
A. J. Livingston, Kinder Morgan
W. J. Mauro, American Electric Power
J. E. Meyer, Louis Perry Group
M. L. Nayyar, NICE
S. K. Sinha, Lucius Pitkin, Inc.
J. S. Willis, Page Southerland Page, Inc.

B31 CONFERENCE GROUP

A. Bell, Bonneville Power Administration
R. A. Coomes, Commonwealth of Kentucky, Department of Housing/Boiler Section
D. H. Hanrath
C. J. Harvey, Alabama Public Service Commission
D. T. Jagger, Ohio Department of Commerce
K. T. Lau, Alberta Boilers Safety Association
R. G. Marini, New Hampshire Public Utilities Commission
I. W. Mault, Manitoba Department of Labour
A. W. Meiring, Fire and Building Safety Division, Boilers and Pressure Vessels Section/Indiana

R. F. Mullaney, Boiler and Pressure Vessel Safety Branch/Vancouver
P. Sher, State of Connecticut
D. A. Starr, Nebraska Department of Labor, Office of Safety
D. J. Sturmsma, Iowa Utilities Board
R. P. Sullivan, The National Board of Boiler and Pressure Vessel Inspectors
J. E. Troppman, Division of Labor/State of Colorado Boiler Inspections
W. A. M. West, Lighthouse Assistance, Inc.
T. F. Wickham, Rhode Island Department of Labor

B31 FABRICATION AND EXAMINATION COMMITTEE

J. Swezy, Jr., *Chair*, Boiler Code Tech, LLC
U. D'Urso, *Secretary*, The American Society of Mechanical Engineers
R. D. Campbell, Bechtel
R. D. Couch, Electric Power Research Institute
R. J. Ferguson, Metallurgist
P. D. Flenner, Flenner Engineering Services

S. Gingrich, AECOM
J. Hainsworth
A. Nalbandian, Thielsch Engineering, Inc.
R. J. Silvia, Process Engineers & Constructors, Inc.
W. Sperko, Sperko Engineering Services, Inc.
P. Vaughan, ONEOK Partners
K. Wu, Stellar Energy Systems

B31 MATERIALS TECHNICAL COMMITTEE

R. A. Grichuk, *Chair*, Fluor Enterprises, Inc.
G. Eisenberg, *Secretary*, The American Society of Mechanical Engineers
B. T. Bounds, Bechtel Corp.
W. Collins, WPC Solutions, LLC
P. Deubler, Fronek Power Systems, LLC
C. Eskridge, Jr., Jacobs Engineering
A. A. Hassan, Power Generation Engineering and Services Co.

G. Jolly, Flowserve/Gestra, USA
C. J. Melo, Technip USA, Inc.
M. L. Nayyar, NICE
M. B. Pickell, Willbros Engineers, Inc.
D. W. Raho, CCM 2000
R. A. Schmidt, Canadoil
J. L. Smith, Jacobs Engineering
Z. Djalali, *Contributing Member*, Sonatrach

B31.1 INDIA INTERNATIONAL WORKING GROUP

A. Kumar, *Chair*, Bechtel India
G. Ravichandran, *Vice Chair*, Bharat Heavy Electricals Ltd.
V. D. Bharani, CH2M Hill
S. Chauhan, GAIL (India) Ltd.
D. D. Christian, Victaulic
A. Gupta, GAIL Training Institute
B. P. Gupta, PVGRB/QCI/GAIL

N. Khera, CH2M Hill India Pvt. Ltd.
P. S. Khinchi, GAIL (India) Ltd.
T. Monani, Foster Wheeler India
S. S. Palkar, CB&I India Private Ltd.
V. T. Randeria, Gujarat Gas Ltd.
D. V. Shastry, GAIL (India) Ltd., GAIL Training Institute
M. Sharma, *Contributing Member*, ASME India Pvt. Ltd.

B31 MECHANICAL DESIGN TECHNICAL COMMITTEE

- G. Antaki**, *Chair*, Becht Engineering Co., Inc.
J. E. Meyer, *Vice Chair*, Louis Perry Group
R. Lucas, *Secretary*, The American Society of Mechanical Engineers
D. Arnett, Pipe Stress Engineer
C. Becht IV, Becht Engineering Co.
R. Bethea, Newport News Shipbuilding
P. Cakir-Kavcar, Bechtel Corp.
N. Consumo, Sr.
J. P. Ellenberger
D. J. Fetzner, BP Exploration Alaska, Inc.
D. Fraser, NASA Ames Research Center
J. A. Graziano, Consultant
J. D. Hart, SSD, Inc.
- R. W. Haupt**, Pressure Piping Engineering Associates, Inc.
B. P. Holbrook, Babcock Power, Inc.
W. J. Koves, Pi Engineering Software, Inc.
R. A. Leishear, Savannah River National Laboratory
G. D. Mayers, Alion Science & Technology
J. F. McCabe, General Dynamics Electric Boat
T. Q. McCawley, TQM Engineering
J. Minichiello, Bechtel National, Inc.
A. Paulin, Paulin Research Group
R. A. Robleto, KBR
M. J. Rosenfeld, Kiefner/Applus — RTD
T. Sato, Japan Power Engineering and Inspection Corp.
G. Stevick, Berkeley Engineering and Research, Inc.
E. C. Rodabaugh, *Honorary Member*, Consultant

INTRODUCTION

The ASME B31 Code for Pressure Piping consists of a number of individually published Sections, each an American National Standard, under the direction of ASME Committee B31, Code for Pressure Piping.

Rules for each Section have been developed considering the need for application of specific requirements for various types of pressure piping. Applications considered for each Code Section include

- B31.1 Power Piping: piping typically found in electric power generating stations, in industrial and institutional plants, geothermal heating systems, and central and district heating and cooling systems
- B31.3 Process Piping: piping typically found in petroleum refineries; chemical, pharmaceutical, textile, paper, semiconductor, and cryogenic plants; and related processing plants and terminals
- B31.4 Pipeline Transportation Systems for Liquids and Slurries: piping transporting products that are predominately liquid between plants and terminals and within terminals, pumping, regulating, and metering stations
- B31.5 Refrigeration Piping and Heat Transfer Components: piping for refrigerants and secondary coolants
- B31.8 Gas Transmission and Distribution Piping Systems: piping transporting products that are predominately gas between sources and terminals, including compressor, regulating, and metering stations; and gas gathering pipelines
- B31.9 Building Services Piping: piping typically found in industrial, institutional, commercial, and public buildings, and in multi-unit residences, which does not require the range of sizes, pressures, and temperatures covered in B31.1
- B31.12 Hydrogen Piping and Pipelines: piping in gaseous and liquid hydrogen service, and pipelines in gaseous hydrogen service

This is the B31.1 Power Piping Code Section. Hereafter, in this Introduction and in the text of this Code Section B31.1, where the word *Code* is used without specific identification, it means this Code Section.

It is the owner's responsibility to select the Code Section that most nearly applies to a proposed piping installation. Factors to be considered by the owner include limitations of the Code Section, jurisdictional

requirements, and the applicability of other codes and standards. All applicable requirements of the selected Code Section shall be met. For some installations, more than one Code Section may apply to different parts of the installation. The owner is also responsible for imposing requirements supplementary to those of the selected Code Section, if necessary, to assure safe piping for the proposed installation.

Certain piping within a facility may be subject to other codes and standards, including but not limited to

- ASME Boiler and Pressure Vessel Code, Section III: nuclear power piping

- ANSI Z223.1/NFPA 54 National Fuel Gas Code: piping for fuel gas from the point of delivery to the connection of each fuel utilization device

- NFPA Fire Protection Standards: fire protection systems using water, carbon dioxide, halon, foam, dry chemical, and wet chemicals

- NFPA 85 Boiler and Combustion Systems Hazards Code

- building and plumbing codes, as applicable, for potable hot and cold water, and for sewer and drain systems

The Code sets forth engineering requirements deemed necessary for safe design and construction of pressure piping. While safety is the basic consideration, this factor alone will not necessarily govern the final specifications for any piping system. The designer is cautioned that the Code is not a design handbook; it does not eliminate the need for the designer or for competent engineering judgment.

To the greatest possible extent, Code requirements for design are stated in terms of basic design principles and formulas. These are supplemented as necessary with specific requirements to ensure uniform application of principles and to guide selection and application of piping elements. The Code prohibits designs and practices known to be unsafe and contains warnings where caution, but not prohibition, is warranted.

The specific design requirements of the Code usually revolve around a simplified engineering approach to a subject. It is intended that a designer capable of applying more complete and rigorous analysis to special or unusual problems shall have latitude in the development of such designs and the evaluation of complex or combined stresses. In such cases the designer is responsible for demonstrating the validity of his approach.

This Code Section includes the following:

- (a) references to acceptable material specifications and component standards, including dimensional requirements and pressure–temperature ratings

(b) requirements for design of components and assemblies, including pipe supports

(c) requirements and data for evaluation and limitation of stresses, reactions, and movements associated with pressure, temperature changes, and other forces

(d) guidance and limitations on the selection and application of materials, components, and joining methods

(e) requirements for the fabrication, assembly, and erection of piping

(f) requirements for examination, inspection, and testing of piping

(g) requirements for operation and maintenance of piping systems

It is intended that this edition of Code Section B31.1 not be retroactive. Unless agreement is specifically made between contracting parties to use another issue, or the regulatory body having jurisdiction imposes the use of another issue, the latest edition issued at least 6 months prior to the original contract date for the first phase of activity covering a piping system or systems shall be the governing document for all design, materials, fabrication, erection, examination, and testing for the piping until the completion of the work and initial operation.

Users of this Code are cautioned against making use of revisions without assurance that they are acceptable to the proper authorities in the jurisdiction where the piping is to be installed.

Code users will note that clauses in the Code are not necessarily numbered consecutively. Such discontinuities result from following a common outline, insofar as practicable, for all Code Sections. In this way, corresponding material is correspondingly numbered in most Code Sections, thus facilitating reference by those who have occasion to use more than one Section.

The Code is under the direction of ASME Committee B31, Code for Pressure Piping, which is organized and operates under procedures of The American Society of Mechanical Engineers which have been accredited by the American National Standards Institute. The Committee is a continuing one, and keeps all Code Sections current with new developments in materials, construction, and industrial practice. New editions are published at intervals of two to five years.

When no Section of the ASME Code for Pressure Piping, specifically covers a piping system, at the user's discretion, he/she may select any Section determined

to be generally applicable. However, it is cautioned that supplementary requirements to the Section chosen may be necessary to provide for a safe piping system for the intended application. Technical limitations of the various Sections, legal requirements, and possible applicability of other codes or standards are some of the factors to be considered by the user in determining the applicability of any Section of this Code.

The Committee has established an orderly procedure to consider requests for interpretation and revision of Code requirements. To receive consideration, inquiries must be in writing and must give full particulars (see Mandatory Appendix H covering preparation of technical inquiries). The Committee will not respond to inquiries requesting assignment of a Code Section to a piping installation.

The approved reply to an inquiry will be sent directly to the inquirer. In addition, the question and reply will be published as part of an Interpretation Supplement issued to the applicable Code Section.

A Case is the prescribed form of reply to an inquiry when study indicates that the Code wording needs clarification or when the reply modifies existing requirements of the Code or grants permission to use new materials or alternative constructions. The Case will be published as part of a Case Supplement issued to the applicable Code Section.

The ASME B31 Standards Committee took action to eliminate Code Case expiration dates effective September 21, 2007. This means that all Code Cases in effect as of this date will remain available for use until annulled by the ASME B31 Standards Committee.

Materials are listed in the Stress Tables only when sufficient usage in piping within the scope of the Code has been shown. Materials may be covered by a Case. Requests for listing shall include evidence of satisfactory usage and specific data to permit establishment of allowable stresses, maximum and minimum temperature limits, and other restrictions. Additional criteria can be found in the guidelines for addition of new materials in the ASME Boiler and Pressure Vessel Code, Section II. (To develop usage and gain experience, unlisted materials may be used in accordance with para. 123.1.)

Requests for interpretation and suggestions for revision should be addressed to the Secretary, ASME B31 Committee, Two Park Avenue, New York, NY 10016-5990.

ASME B31.1-2016

SUMMARY OF CHANGES

Following approval by the B31 Committee and ASME, and after public review, ASME B31.1-2016 was approved by the American National Standards Institute on May 31, 2016.

Changes given below are identified on the pages by a margin note, **(16)**, placed next to the affected area.

<i>Page</i>	<i>Location</i>	<i>Change</i>
xii	Introduction	(1) Second paragraph revised (2) Footnote deleted
1–12	100.1.2	In subpara. (A), third and last paragraphs revised
	Fig. 100.1.2(B.1)	Fig. 100.1.2(B) redesignated as Fig. 100.1.2(B.1)
	Fig. 100.1.2(B.2)	Added
	Fig. 100.1.2(B.3)	Added
	100.1.4	Revised
	100.2	(1) Definitions of <i>alteration</i> , <i>cold spring</i> , <i>failure</i> , <i>failure analysis</i> , and <i>repair</i> added (2) Definitions of <i>component</i> and <i>covered piping systems (CPS)</i> revised (3) For <i>stresses</i> , subdefinitions rearranged
15	101.7.2	Revised
19	102.4.6	In subpara. (A), first paragraph revised
21, 24	104.1.2	Subparagraphs (C.3.1) and (C.3.2) revised
	Table 104.1.2(A)	Row for UNS No. N06690 added
25, 31	104.3.1	(1) DN values added in 13 places (2) In subpara. (C.2), cross-references revised
32, 33	104.5.1	In subpara. (A), first two paragraphs revised
34, 35	104.8	Revised
	104.8.1	Nomenclature for S_h revised
	104.8.3	Revised
38	107.4	Revised
41, 43	Table 112	General Note (c) revised
48	119.7.3	Second paragraph revised
	119.10.1	Nomenclature for S_h revised
50	121.4	First paragraph revised
	Table 121.5	Column for Diameter Nominal added

<i>Page</i>	<i>Location</i>	<i>Change</i>
51	121.7.2	In subpara. (A), first paragraph revised
53	122.1.1	In subparas. (E), (F), and (H), DN values added
55–58	122.1.7	Subparagraphs (B.5), (C.5), and (C.12) revised
59	122.3.2	Subparagraph (A.1) revised
60	122.3.6	Subparagraph (A.5) revised
74–80	Table 126.1	(1) API 570 added (2) For MSS SP-45, SP-51, SP-61, SP-75, SP-83, and SP-95, titles revised (3) ASME B31J added (4) For AWS QC1, title revised
84–91	127.4.8	Subparagraph (F) revised
	Fig. 127.4.8(E)	Note (4) revised
	Fig. 127.4.8(F)	Title revised
	Fig. 127.4.8(G)	Title revised
	127.4.10	Revised
94	129.3.3	First paragraph revised
	129.3.3.1	Revised in its entirety
95	Table 129.3.3.1	Added
	129.3.4.5	Revised
96	Table 129.3.4.1	(1) Row for Grade 690 added (2) In last row, Grade deleted (3) Note (2) revised
97, 98	132.1.1	Revised
100, 103	132.4.2	In subparagraph (E), equation revised
104	132.6	Subparagraph (B) revised
106	136.1.4	Revised in its entirety
107–109	136.3.2	Last paragraph revised
	136.4.2	First paragraph revised
	136.4.3	First paragraph revised
	Table 136.4	(1) Seven DN values added (2) General Note (b) revised (3) Note (5) redesignated as (6), and new Note (5) added
	136.4.4	First paragraph revised
110	136.4.5	First paragraph revised
	136.4.6	First paragraph revised
114	138	Last paragraph revised
	139	Subparagraph (E) revised
	140	Third paragraph added

<i>Page</i>	<i>Location</i>	<i>Change</i>
115, 116	141	Revised in its entirety
140, 141	Table A-3	Under Seamless Pipe and Tube, Austenitic, A312 N08904 added
142, 143	Table A-3	A312 TP317LMN added
144, 145	Table A-3	(1) Under Ferritic/Austenitic, A789 and A790 S32101 added (2) For A789 2205, Type or Grade revised (3) For A790 2205, Type or Grade, Specified Minimum Tensile, and stress values revised
148, 149	Table A-3	Under Welded Pipe and Tube — Without Filler Metal, Austenitic, A312 N08904 and TP317LMN added
150, 151	Table A-3	(1) Under Ferritic/Austenitic, A789 and A790 S32101 added (2) For A789 2205, Type or Grade revised (3) For A790 2205, Type or Grade, Specified Minimum Tensile, and stress values revised
156, 157	Table A-3	(1) Under Welded Pipe — Filler Metal Added, Ferritic/Austenitic, A928 2205 added (2) Under Plate, Sheet, and Strip, Austenitic, A240 N08904 added
158, 159	Table A-3	(1) A240 317LMN added (2) Under Ferritic/Austenitic, A240 S32101 added (3) For A240 2205, Type or Grade, Specified Minimum Tensile, and stress values revised (4) Under Forgings, Austenitic, A182 F904L added
162, 163	Table A-3	Under Fittings (Seamless and Welded), Austenitic, for A403 WP304 and WP304H, Notes revised
164, 165	Table A-3	(1) A403 WPS31726 added (2) Under Ferritic/Austenitic, A815 S32101 added
166, 167	Table A-3	Under Bar, Austenitic, A479 N08904 and 317LMN added
168, 169	Table A-3	(1) Under Ferritic/Austenitic, A479 S32101 and 2205 added (2) Note (23) revised
170, 171	Table A-4	(1) Under Seamless Pipe and Tube, B167 N06690 added (2) For B444 N06625, Notes revised, and stress values for 1,150°F and 1,200°F deleted

<i>Page</i>	<i>Location</i>	<i>Change</i>
174, 175	Table A-4	<ul style="list-style-type: none"> (1) Under Welded Pipe and Tube, for B704 and B705 N06625, Notes revised, and stress values for 1,150°F and 1,200°F deleted (2) Under Plate, Sheet, and Strip, B168 N06690 added (3) For B443 N06625, Notes revised, and stress values for 1,150°F and 1,200°F deleted
176, 177	Table A-4	<ul style="list-style-type: none"> (1) Under Bars, Rods, Shapes, and Forgings, B166 N06690 added (2) For B446 and B564 N06625, Notes revised, and stress values for 1,150°F and 1,200°F deleted
178, 179	Table A-4	Under Welded Fittings, for B366 N06625, Notes revised, and stress values for 1,150°F and 1,200°F deleted
181	Table A-4	Note (23) added
182, 183	Table A-5	<ul style="list-style-type: none"> (1) Column for -20°F to 650°F deleted (2) Under Gray Cast Iron, for A126 Classes A, B, and C, Notes revised (3) For A278 Classes 40 through 60, stress values added (4) Under Ductile Cast Iron, for A395 60-40-18, A536 60-42-10, and A536 70-50-05, stress values added
188, 189	Table A-7	<ul style="list-style-type: none"> (1) Under Drawn Seamless Tube, for B210 A96061 T4, stress value for 250°F revised (2) For B210 A96061 T6, stress values for 250°F and 300°F revised (3) For B210 A96061 T4, T6 welded, Specified Minimum Yield deleted and first four stress values revised (4) Under Seamless Pipe and Seamless Extruded Tube, for B241 A95083 H112, Notes revised (5) For B241 A96061 T4, stress value for 250°F revised (6) For first B241 A96061 T6, Size or Thickness and stress value for 250°F revised (7) For second B241 A96061 T6, Size or Thickness, Notes, and stress values for 250°F and 300°F revised (8) For B241 A96061 T4, T6 welded, Specified Minimum Yield deleted and first four stress values revised (9) Under Drawn Seamless Condenser and Heat Exchanger Tube, for B234 A96061 T4, stress value for 250°F revised

<i>Page</i>	<i>Location</i>	<i>Change</i>
190, 191	Table A-7	<ul style="list-style-type: none"> (10) For B234 A96061 T6, stress values for 250°F and 300°F revised (11) For B234 A96061 T4, T6 welded, Specified Minimum Yield deleted and first four stress values revised (1) Under Arc-Welded Round Tube, eight B547 A96061 lines referencing Note (25) added (2) Under Sheet and Plate, for B209 A96061 T4, Size or Thickness and stress value for 250°F revised (3) For B209 A96061 T451, stress value for 250°F revised (4) For B209 A96061 T4 welded, Size or Thickness revised, Specified Minimum Yield deleted, and first four stress values revised (5) For B209 A96061 T451 welded, Specified Minimum Yield deleted and first four stress values revised (6) For B209 A96061 T6 and T651, stress value for 250°F revised (7) For B209 A96061 T6 welded and T651 welded, Specified Minimum Yield deleted and first four stress values revised
192, 193	Table A-7	<ul style="list-style-type: none"> (1) Under Die and Hand Forgings, for B247 A96061 T6, stress value for 250°F revised (2) For B247 A96061 T6 welded, Specified Minimum Yield deleted and first four stress values revised (3) Under Rods, Bars, and Shapes, for B221 A96061 T4 and T6, stress value for 250°F revised (4) For A96061 T4 welded and T6 welded, Specified Minimum Yield deleted and first four stress values revised
195	Table A-7	<ul style="list-style-type: none"> (1) Note (17) revised (2) Notes (24) and (25) added
208, 209	Table A-10	Under Stainless Steels, Austenitic, for A453 660, stress values for 200°F through 1,000°F added
233–235	Mandatory Appendix F	<ul style="list-style-type: none"> (1) For ASCE/SEI 7, newer edition added (2) Editions updated for ASTM A240/A240M, A312/A312M, A403/A403M, A479/A479M, A789/A789M, A790/A790M, A928/A928M, B166, B167, and B168 (3) Editions updated for 16 MSS standard practices (4) API 570 and ASME B31J added (5) List of organizations updated

<i>Page</i>	<i>Location</i>	<i>Change</i>
237–243	Mandatory Appendix G	(1) D_n , q , and ΔT deleted (2) References updated for D_o , d_n , f , N , N_E , N_i , P , S_c , S_{hr} , S_{ip} , S_A , and SE (3) q_i added
298	IV-5.2	Second paragraph revised
	Table IV-5.2	SI units added
	IV-5.3	Revised
301	V-3.1	Revised
	V-4	First paragraph revised
302, 303	V-6	Revised in its entirety
309	V-10	Revised in its entirety
312	V-14	Added

INTENTIONALLY LEFT BLANK

POWER PIPING

Chapter I Scope and Definitions

100 GENERAL

This Power Piping Code is one of several Sections of the American Society of Mechanical Engineers Code for Pressure Piping, B31. This Section is published as a separate document for convenience.

Standards and specifications specifically incorporated by reference into this Code are shown in Table 126.1. It is not considered practical to refer to a dated edition of each of the standards and specifications in this Code. Instead, the dated edition references are included in an Addenda and will be revised yearly.

100.1 Scope

Rules for this Code Section have been developed considering the needs for applications that include piping typically found in electric power generating stations, in industrial and institutional plants, geothermal heating systems, and central and district heating and cooling systems.

100.1.1 This Code prescribes requirements for the design, materials, fabrication, erection, test, inspection, operation, and maintenance of piping systems.

Piping as used in this Code includes pipe, flanges, bolting, gaskets, valves, pressure-relieving valves/devices, fittings, and the pressure-containing portions of other piping components, whether manufactured in accordance with Standards listed in Table 126.1 or specially designed. It also includes hangers and supports and other equipment items necessary to prevent overstressing the pressure-containing components.

Rules governing piping for miscellaneous appurtenances, such as water columns, remote water level indicators, pressure gages, gage glasses, etc., are included within the scope of this Code, but the requirements for boiler appurtenances shall be in accordance with Section I of the ASME Boiler and Pressure Vessel Code, PG-60.

The users of this Code are advised that in some areas legislation may establish governmental jurisdiction over the subject matter covered by this Code. However, any such legal requirement shall not relieve the owner of his inspection responsibilities specified in para. 136.1.

100.1.2 Power piping systems as covered by this Code apply to all piping and their component parts except as excluded in para. 100.1.3. They include but are not limited to steam, water, oil, gas, and air services. (16)

(A) This Code covers boiler external piping as defined below for power boilers and high-temperature, high-pressure water boilers in which steam or vapor is generated at a pressure of more than 15 psig [100 kPa (gage)]; and high temperature water is generated at pressures exceeding 160 psig [1 103 kPa (gage)] and/or temperatures exceeding 250°F (120°C).

Boiler external piping shall be considered as piping that begins where the boiler proper terminates at

- (1) the first circumferential joint for welding end connections; or
- (2) the face of the first flange in bolted flanged connections; or
- (3) the first threaded joint in that type of connection; and that extends up to and including the valve or valves required by para. 122.1.

The terminal points themselves are considered part of the boiler external piping. The terminal points and piping external to power boilers are illustrated by Figs. 100.1.2(A.1), 100.1.2(A.2), 100.1.2(B.1), 100.1.2(B.2), 100.1.2(B.3), and 100.1.2(C).

Piping between the terminal points and the valve or valves required by para. 122.1 shall be provided with Data Reports, inspection, and stamping as required by Section I of the ASME Boiler and Pressure Vessel Code. All welding and brazing of this piping shall be performed by manufacturers or contractors authorized to use the ASME Certification Mark and appropriate Designators shown in Figs. PG-105.1 through PG-109 of Section I of the ASME Boiler and Pressure Vessel Code. The installation of boiler external piping by mechanical means may be performed by an organization not holding an ASME Certification Mark. However, the holder of a valid ASME Certification Mark, Certificate of Authorization, with an "S," "A," or "PP" Designator shall be responsible for the documentation and hydrostatic test, regardless of the method of assembly. The quality control system requirements of Section I of the

Fig. 100.1.2(A.1) Code Jurisdictional Limits for Piping – An Example of Forced Flow Steam Generators With No Fixed Steam and Water Line

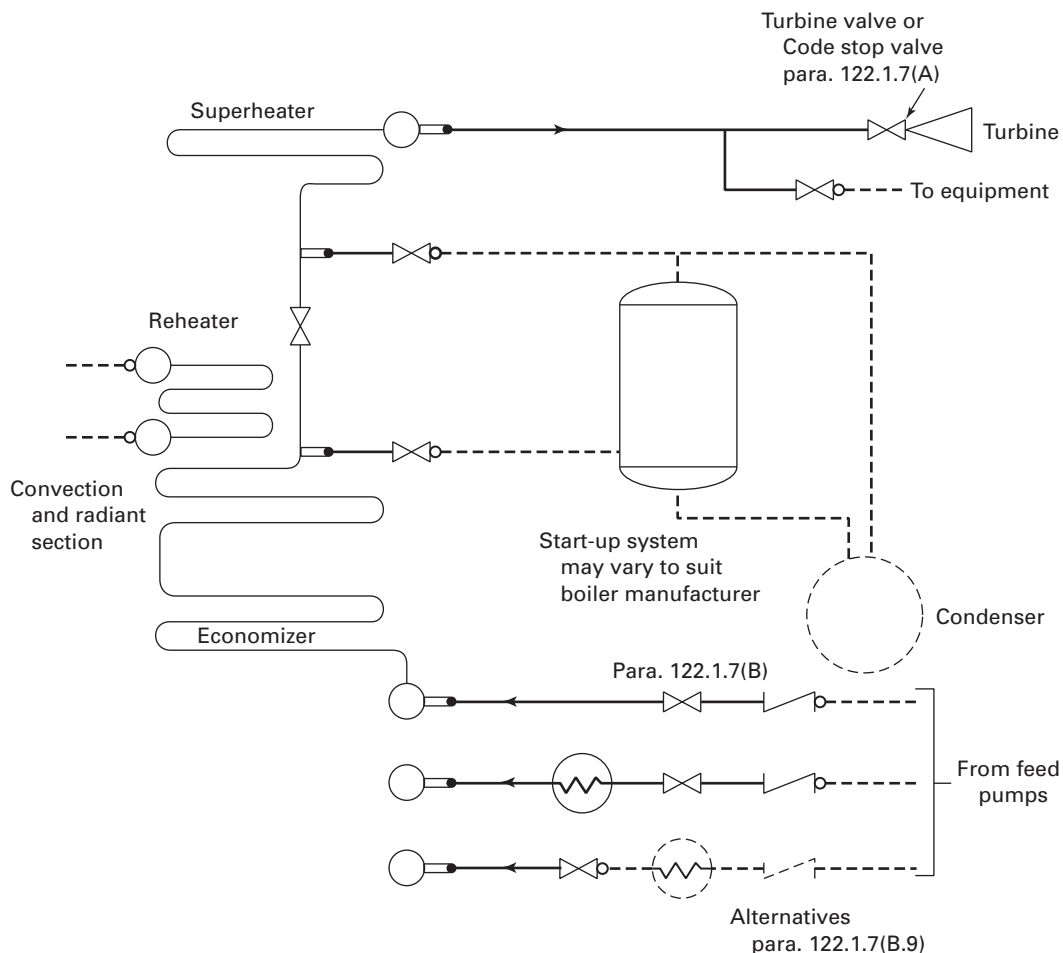

Administrative Jurisdiction and Technical Responsibility

- Boiler Proper — The ASME Boiler and Pressure Vessel Code (ASME BPVC) has total administrative jurisdiction and technical responsibility. Refer to ASME BPVC Section I Preamble.
- Boiler External Piping and Joint (BEP) — The ASME BPVC has total administrative jurisdiction (mandatory certification by stamping the Certification Mark with the appropriate Designator, ASME Data Forms, and Authorized Inspection) of BEP. The ASME Section Committee B31.1 has been assigned technical responsibility. Refer to ASME BPVC Section I Preamble, fifth, sixth, and seventh paragraphs and ASME B31.1 Scope, para. 100.1.2(A). Applicable ASME B31.1 Editions and Addenda are referenced in ASME BPVC Section I, PG-58.3.
- Nonboiler External Piping and Joint (NBEP) — The ASME Code Committee for Pressure Piping, B31, has total administrative and technical responsibility.

Fig. 100.1.2(A.2) Code Jurisdictional Limits for Piping – An Example of Steam Separator Type Forced Flow Steam Generators With No Fixed Steam and Water Line

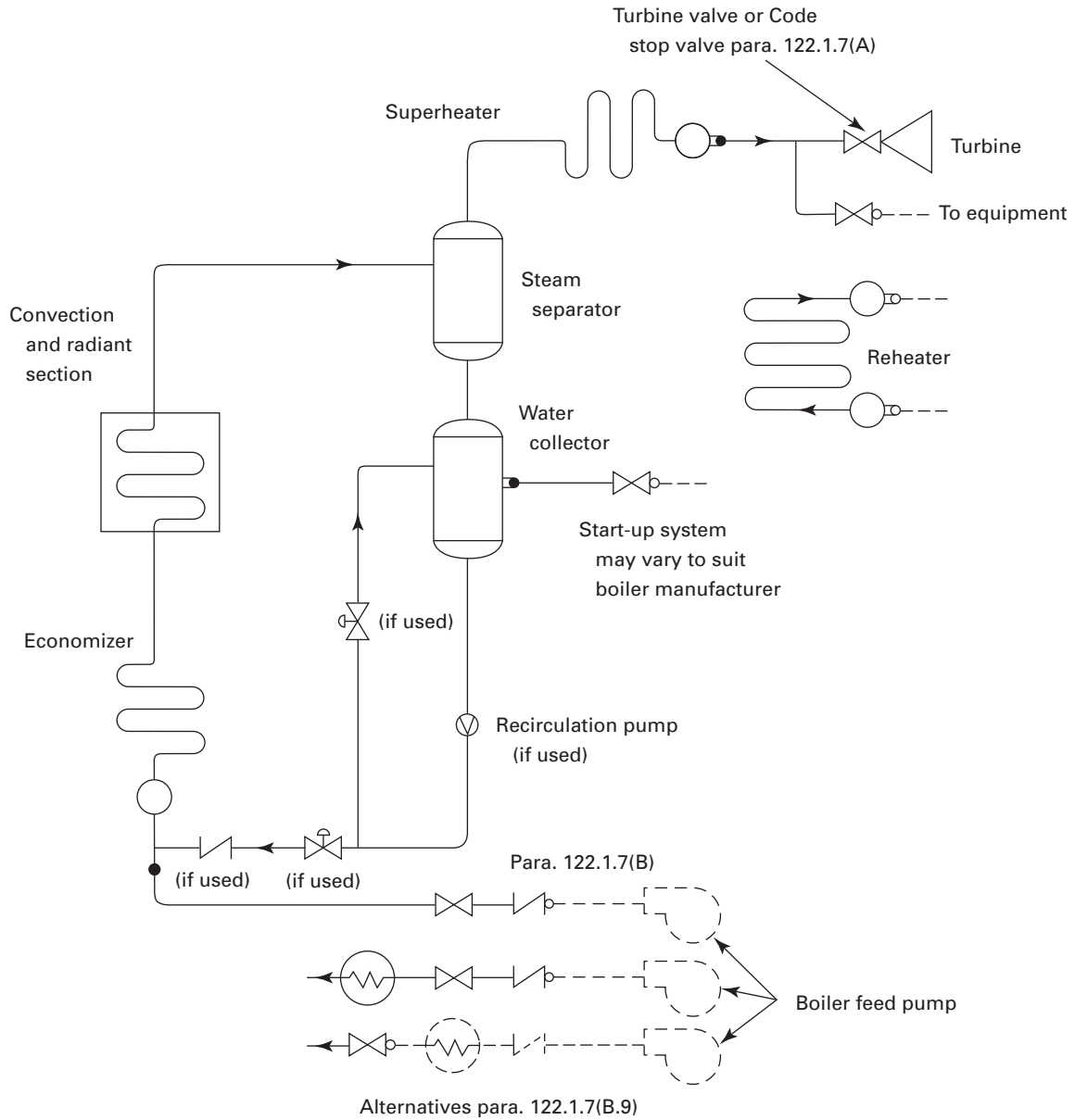

Administrative Jurisdiction and Technical Responsibility

- Boiler Proper – The ASME Boiler and Pressure Vessel Code (ASME BPVC) has total administrative jurisdiction and technical responsibility. Refer to ASME BPVC Section I Preamble.
- Boiler External Piping and Joint (BEP) – The ASME BPVC has total administrative jurisdiction (mandatory certification by stamping the Certification Mark with the appropriate Designator, ASME Data Forms, and Authorized Inspection) of BEP. The ASME Section Committee B31.1 has been assigned technical responsibility. Refer to ASME BPVC Section I Preamble, fifth, sixth, and seventh paragraphs and ASME B31.1 Scope, para. 100.1.2(A). Applicable ASME B31.1 Editions and Addenda are referenced in ASME BPVC Section I, PG-58.3.
- Nonboiler External Piping and Joint (NBEP) – The ASME Code Committee for Pressure Piping, B31, has total administrative and technical responsibility.

(16) **Fig. 100.1.2(B.1) Code Jurisdictional Limits for Piping — Drum-Type Boilers**

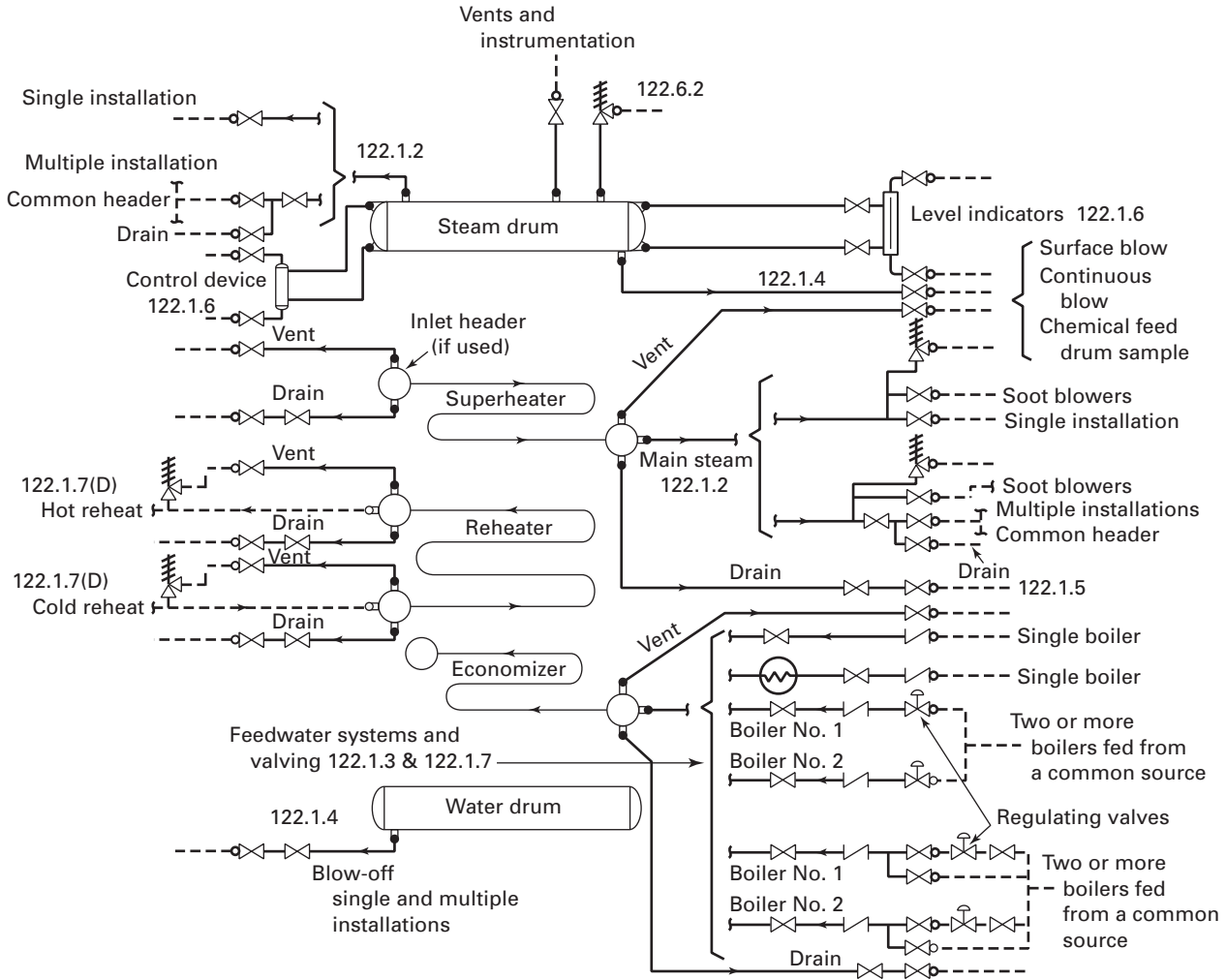

Administrative Jurisdiction and Technical Responsibility

- Boiler Proper — The ASME Boiler and Pressure Vessel Code (ASME BPVC) has total administrative jurisdiction and technical responsibility. Refer to ASME BPVC Section I Preamble.
- Boiler External Piping and Joint (BEP) — The ASME BPVC has total administrative jurisdiction (mandatory certification by stamping the Certification Mark with the appropriate Designator, ASME Data Forms, and Authorized Inspection) of BEP. The ASME Section Committee B31.1 has been assigned technical responsibility. Refer to ASME BPVC Section I Preamble and ASME B31.1 Scope, para. 100.1.2(A). Applicable ASME B31.1 Editions and Addenda are referenced in ASME BPVC Section I, PG-58.3.
- Nonboiler External Piping and Joint (NBEP) — The ASME Code Committee for Pressure Piping, B31, has total administrative jurisdiction and technical responsibility.

(16) **Fig. 100.1.2(B.2) Code Jurisdictional Limits for Piping — Isolable Economizers Located in Feedwater Piping and Isolable Superheaters in Main Steam Piping (Boiler Pressure Relief Valves, Blowoff, and Miscellaneous Piping for Boiler Proper Not Shown for Clarity)**

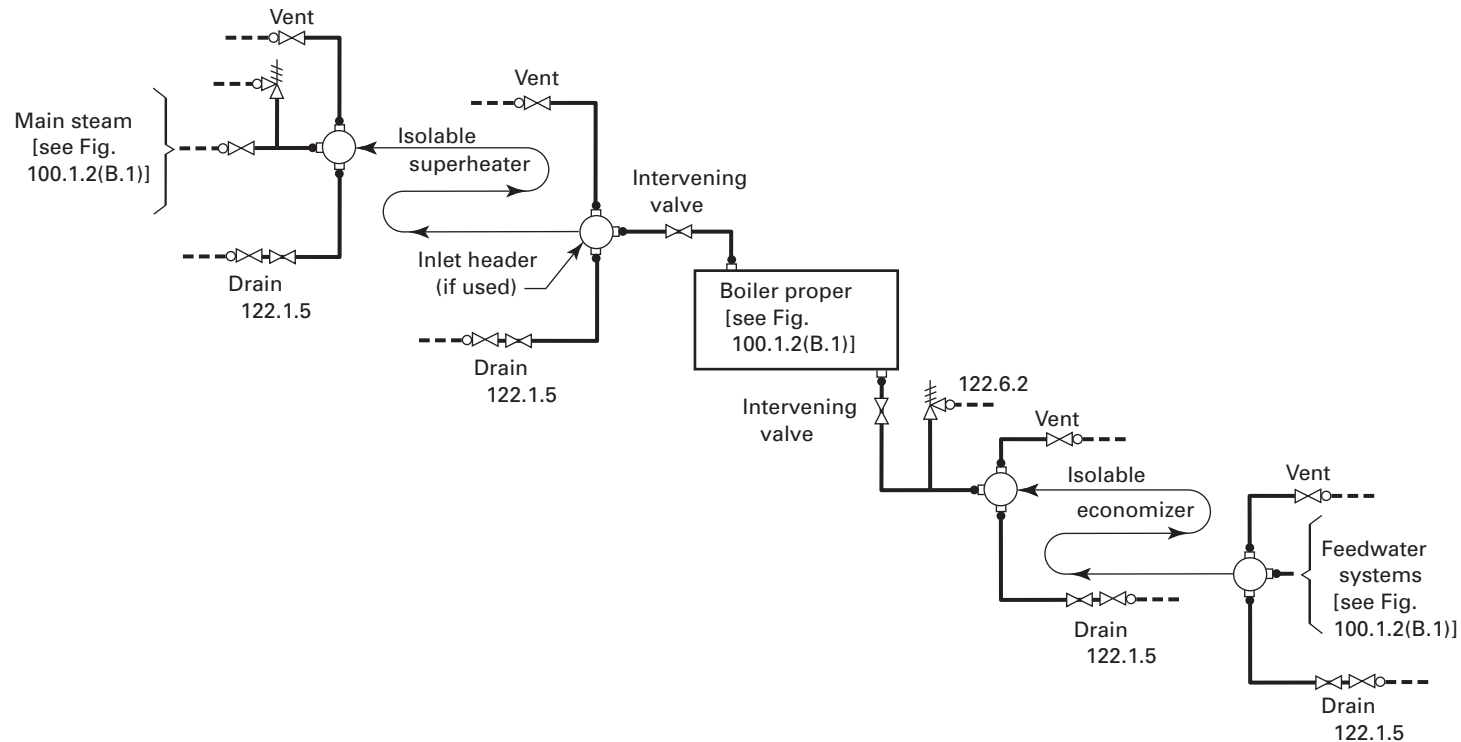

Administrative Jurisdiction and Technical Responsibility

- Boiler Proper — The ASME Boiler and Pressure Vessel Code (ASME BPVC) has total administrative jurisdiction and technical responsibility. Refer to ASME BPVC Section I Preamble.
- Boiler External Piping and Joint (BEP) — The ASME BPVC has total administrative jurisdiction (mandatory certification by stamping the Certification Mark with the appropriate Designator, ASME Data Forms, and Authorized Inspection) of BEP. The ASME Section Committee B31.1 has been assigned technical responsibility. Refer to ASME BPVC Section I Preamble and ASME B31.1 Scope, para. 100.1.2(A). Applicable ASME B31.1 Editions and Addenda are referenced in ASME BPVC Section I, PG-58.3.
- Nonboiler External Piping and Joint (NBEP) — The ASME Code Committee for Pressure Piping, B31, has total administrative jurisdiction and technical responsibility.

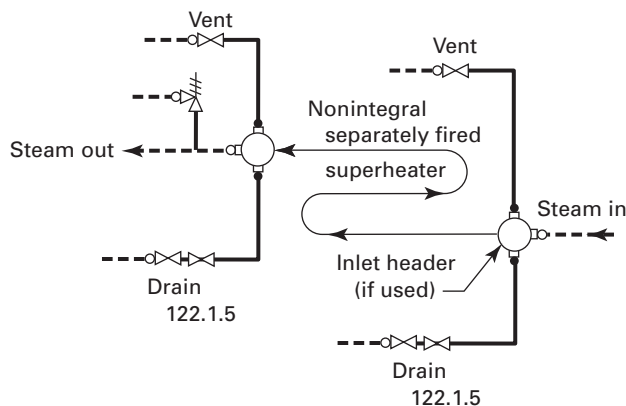
(16) **Fig. 100.1.2(B.3) Code Jurisdictional Limits for Piping — Nonintegral Separately Fired Superheaters**

Administrative Jurisdiction and Technical Responsibility

- Boiler Proper — The ASME Boiler and Pressure Vessel Code (ASME BPVC) has total administrative jurisdiction and technical responsibility. Refer to ASME BPVC Section I Preamble.
- Boiler External Piping and Joint (BEP) — The ASME BPVC has total administrative jurisdiction (mandatory certification by stamping the Certification Mark with the appropriate Designator, ASME Data Forms, and Authorized Inspection) of BEP. The ASME Section Committee B31.1 has been assigned technical responsibility. Refer to ASME BPVC Section I Preamble and ASME B31.1 Scope, para. 100.1.2(A). Applicable ASME B31.1 Editions and Addenda are referenced in ASME BPVC Section I, PG-58.3.
- Nonboiler External Piping and Joint (NBEP) — The ASME Code Committee for Pressure Piping, B31, has total administrative jurisdiction and technical responsibility.

ASME Boiler and Pressure Vessel Code shall apply. These requirements are shown in Mandatory Appendix J of this Code.

The valve or valves required by para. 122.1 are part of the boiler external piping, but do not require ASME Boiler and Pressure Vessel Code, Section I inspection and stamping except for safety, safety relief, and relief valves; see para. 107.8.2. Refer to PG-11.

Pipe connections meeting all other requirements of this Code but not exceeding NPS $\frac{1}{2}$ (DN 15) may be welded to pipe or boiler headers without inspection and stamping required by Section I of the ASME Boiler and Pressure Vessel Code.

(B) Nonboiler external piping includes all the piping covered by this Code except for that portion defined above as boiler external piping.

100.1.3 This Code does not apply to the following:

(A) economizers, heaters, pressure vessels, and components covered by Sections of the ASME Boiler and Pressure Vessel Code.

(B) building heating and distribution steam and condensate piping designed for 15 psig [100 kPa (gage)] or

less, or hot water heating systems designed for 30 psig [200 kPa (gage)] or less.

(C) piping for hydraulic or pneumatic tools and their components downstream of the first block or stop valve off the system distribution header.

(D) piping for marine or other installations under Federal control.

(E) towers, building frames, tanks, mechanical equipment, instruments, and foundations.

(F) piping included as part of a shop-assembled packaged equipment assembly within a B31.1 Code piping installation when such equipment piping is constructed to another B31 Code Section (e.g., B31.3 or B31.9) with the owner's approval. See para. 100.2 for a definition of packaged equipment.

100.1.4 This Code does not provide procedures for flushing, cleaning, start-up, operating, or maintenance. (16)

100.2 Definitions (16)

Some commonly used terms relating to piping are defined below. Terms related to welding generally agree with AWS A3.0. Some welding terms are defined with

Fig. 100.1.2(C) Code Jurisdictional Limits for Piping — Spray-Type Desuperheater

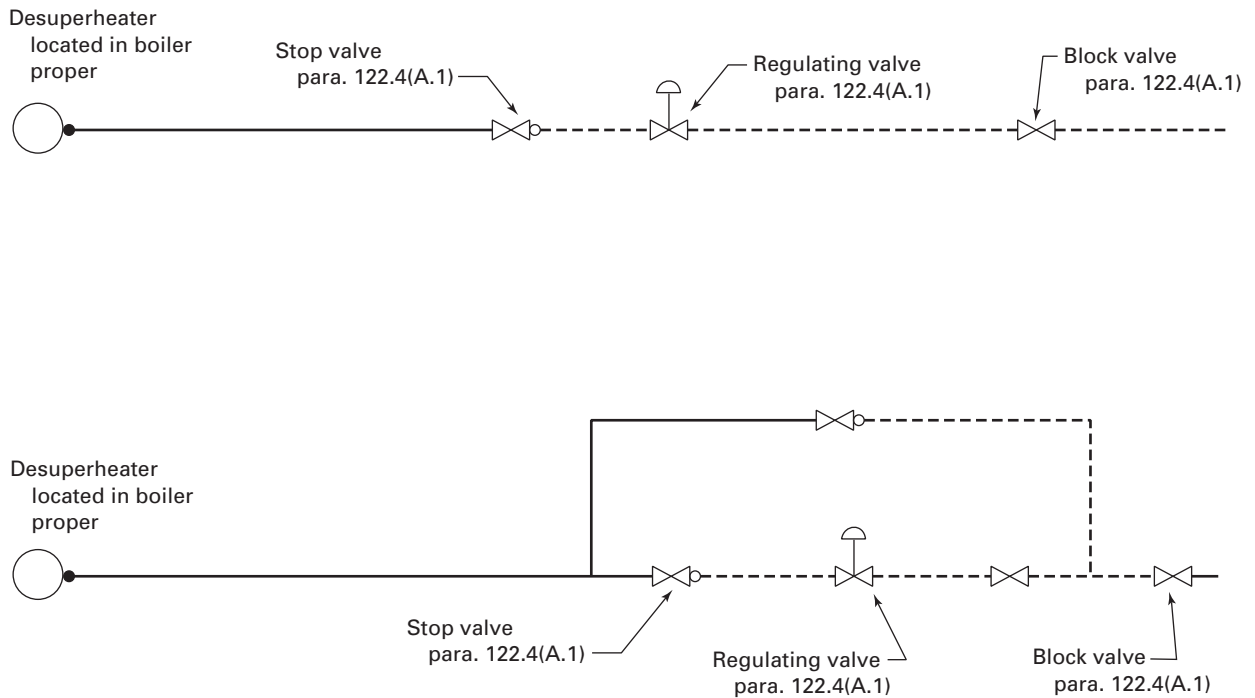

Administrative Jurisdiction and Technical Responsibility

- Boiler Proper — The ASME Boiler and Pressure Vessel Code (ASME BPVC) has total administrative jurisdiction and technical responsibility. Refer to ASME BPVC Section 1 Preamble.
- Boiler External Piping and Joint (BEP) — The ASME BPVC has total administrative jurisdiction (mandatory certification by stamping the Certification Mark with the appropriate Designator, ASME Data Forms, and Authorized Inspection) of BEP. The ASME Section Committee B31.1 has been assigned technical responsibility. Refer to ASME BPVC Section I Preamble and ASME B31.1 Scope, para. 100.1.2(A). Applicable ASME B31.1 Editions and Addenda are referenced in ASME BPVC Section I, PG-58.3.
- Nonboiler External Piping and Joint (NBEP) — The ASME Code Committee for Pressure Piping, B31, has total administrative and technical responsibility.

specified reference to piping. For welding terms used in this Code, but not shown here, definitions of AWS A3.0 apply.

alteration: a change in any item described in the original design that affects the pressure-containing capability of the pressure-retaining component.

anchor: a rigid restraint providing substantially full fixation, permitting neither translatory nor rotational displacement of the pipe.

annealing: see *heat treatments*.

arc welding: a group of welding processes wherein coalescence is produced by heating with an electric arc or arcs, with or without the application of pressure and with or without the use of filler metal.

assembly: the joining together of two or more piping components by bolting, welding, caulking, brazing, soldering, cementing, or threading into their installed location as specified by the engineering design.

automatic welding: welding with equipment that performs the entire welding operation without constant observation and adjustment of the controls by an operator. The equipment may or may not perform the loading and unloading of the work.

backing ring: backing in the form of a ring that can be used in the welding of piping.

ball joint: a component that permits universal rotational movement in a piping system.

base metal: the metal to be welded, brazed, soldered, or cut.

branch connection: the attachment of a branch pipe to the run of a main pipe with or without the use of fittings.

braze welding: a method of welding whereby a groove, fillet, plug, or slot weld is made using a nonferrous filler metal having a melting point below that of the base metals, but above 840°F (450°C). The filler metal is not distributed in the joint by capillary action. (Bronze welding, formerly used, is a misnomer for this term.)

brazing: a metal joining process wherein coalescence is produced by use of a nonferrous filler metal having a melting point above 840°F (450°C) but lower than that of the base metals joined. The filler metal is distributed between the closely fitted surfaces of the joint by capillary action.

butt joint: a joint between two members lying approximately in the same plane.

capacitor discharge welding (CDW): stud arc welding process in which DC arc power is produced by a rapid discharge of stored electrical energy with pressure applied during or immediately following the electrical discharge. The process uses an electrostatic storage system as a power source in which the weld energy is stored in capacitors.

cold spring: the intentional movement of piping during assembly to produce a desired initial displacement and reaction.

component: component as used in this Code is defined as consisting of but not limited to items such as pipe, piping subassemblies, parts, valves, strainers, relief devices, fittings, pipe supports and hangers, etc.

pecially designed component: a component designed in accordance with para. 104.7.2.

standard component: a component manufactured in accordance with one or more of the standards listed in Table 126.1.

covered piping systems (CPS): piping systems on which condition assessments are to be conducted. As a minimum for electric power generating stations, the CPS systems are to include NPS 4 (DN 100) and larger of the main steam, hot reheat steam, cold reheat steam, and boiler feedwater piping systems. In addition to the above, CPS also includes NPS 4 (DN 100) and larger piping in other systems that operate above 750°F (400°C) or above 1,025 psi (7 100 kPa). The Operating Company may add other piping systems to the scope of covered piping systems.

creep strength enhanced ferritic steel: steel in which the microstructure, consisting of lower transformation products such as martensite and bainite, is stabilized by controlled precipitation of temper-resistant carbides, carbonitrides, and/or nitrides.

defect: a flaw (imperfection or unintentional discontinuity) of such size, shape, orientation, location, or properties as to be rejectable.

discontinuity: a lack of continuity or cohesion; an interruption in the normal physical structure of material or a product.

employer: the owner, manufacturer, fabricator, contractor, assembler, or installer responsible for the welding, brazing, and NDE performed by his organization including procedure and performance qualifications.

engineering design: the detailed design developed from process requirements and conforming to Code requirements, including all necessary drawings and specifications, governing a piping installation.

equipment connection: an integral part of such equipment as pressure vessels, heat exchangers, pumps, etc., designed for attachment of pipe or piping components.

erection: the complete installation of a piping system, including any field assembly, fabrication, testing, and inspection of the system.

examination: denotes the procedures for all nondestructive examination. Refer to para. 136.3 and the definition for visual examination.

expansion joint: a flexible piping component that absorbs thermal and/or terminal movement.

fabrication: primarily, the joining of piping components into integral pieces ready for assembly. It includes bending, forming, threading, welding, or other operations upon these components, if not part of assembly. It may be done in a shop or in the field.

face of weld: the exposed surface of a weld on the side from which the welding was done.

failure: a physical condition that renders a system or component unable to perform its intended function(s) or is a hazard to personnel safety.

failure analysis: the process of collecting and evaluating data to determine the damage mechanism(s) and cause of a failure.

filler metal: metal to be added in welding, soldering, brazing, or braze welding.

fillet weld: a weld of approximately triangular cross section joining two surfaces approximately at right angles to each other in a lap joint, tee joint, corner joint, or socket weld.

fire hazard: situation in which a material of more than average combustibility or explosibility exists in the presence of a potential ignition source.

flaw: an imperfection or unintentional discontinuity that is detectable by a nondestructive examination.

full fillet weld: a fillet weld whose size is equal to the thickness of the thinner member joined.

fusion: the melting together of filler metal and base metal, or of base metal only, that results in coalescence.

gas blow: a process to clean and remove debris from the gas supply piping by releasing gas (flammable or nonflammable) at a high pressure and velocity through the piping system while venting to atmosphere.

gas purge: a process to purge air from the flammable gas supply piping, typically conducted at a low pressure and velocity.

gas welding: a group of welding processes wherein coalescence is produced by heating with a gas flame or flames, with or without the application of pressure, and with or without the use of filler metal.

groove weld: a weld made in the groove between two members to be joined.

heat affected zone: portion of the base metal that has not been melted, but whose mechanical properties or microstructure have been altered by the heat of welding or cutting.

heat treatments

annealing, full: heating a metal or alloy to a temperature above the critical temperature range and holding above the range for a proper period of time, followed by cooling to below that range. (A softening treatment is often carried out just below the critical range, which is referred to as a subcritical anneal.)

normalizing: a process in which a ferrous metal is heated to a suitable temperature above the transformation range and is subsequently cooled in still air at room temperature.

postweld heat treatment: any heat treatment subsequent to welding.

preheating: the application of heat to a base metal immediately prior to a welding or cutting operation.

stress-relieving: uniform heating of a structure or portion thereof to a sufficient temperature to relieve the major portion of the residual stresses, followed by uniform cooling.

imperfection: a condition of being imperfect; a departure of a quality characteristic from its intended condition.

indication: the response or evidence from the application of a nondestructive examination.

inert gas metal arc welding: an arc welding process wherein coalescence is produced by heating with an electric arc between a metal electrode and the work. Shielding is obtained from an inert gas, such as helium or argon. Pressure may or may not be used and filler metal may or may not be used.

inspection: denotes the activities performed by an Authorized Inspector, or an owner's Inspector, to verify that all required examinations and testing have been completed, and to ensure that all the documentation for material, fabrication, and examination conforms to the applicable requirements of this Code and the engineering design.

integrally reinforced branch outlet fitting: a branch outlet fitting that is welded directly to a run pipe, where the branch fitting and the deposited weld metal used to attach the fitting to the run pipe are designed by the fitting manufacturer to provide all the reinforcement required by this Code without the addition of separate saddles or pads. The attachment of the branch pipe to the fitting is by butt welding, socket welding, threading, or by a flanged connection. Integrally reinforced branch outlet fittings include those fittings conforming to MSS SP-97.

joint design: the joint geometry together with the required dimensions of the welded joint.

joint penetration: the minimum depth of a groove weld extends from its face into a joint, exclusive of reinforcement.

low energy capacitor discharge welding: a resistance welding process wherein coalescence is produced by the rapid discharge of stored electric energy from a low voltage electrostatic storage system.

manual welding: welding wherein the entire welding operation is performed and controlled by hand.

maximum allowable stress: the maximum stress value that may be used in the design formulas for a given material and design temperature.

maximum allowable working pressure (MAWP): the pressure at the coincident temperature to which a boiler or pressure vessel can be subjected without exceeding the maximum allowable stress of the material or pressure-temperature rating of the equipment. For this Code, the term “MAWP” is as defined in the ASME Boiler and Pressure Vessel Code, Sections I and VIII.

may: used to denote permission; neither a requirement nor a recommendation.

mechanical joint: a joint for the purpose of mechanical strength or leak resistance, or both, where the mechanical strength is developed by threaded, grooved, rolled, flared, or flanged pipe ends, or by bolts, pins, and compounds, gaskets, rolled ends, caulking, or machined and mated surfaces. These joints have particular application where ease of disassembly is desired.

miter: two or more straight sections of pipe matched and joined on a line bisecting the angle of junction so as to produce a change in direction.

nominal thickness: the thickness given in the product material specification or standard to which manufacturing tolerances are applied.

normalizing: see *heat treatments*.

Operating Company: the owner, user, or agent acting on behalf of the owner, who has the responsibility for performing the operations and maintenance functions on the piping systems within the scope of the Code.

owner: the party or organization ultimately responsible for operation of a facility. The owner is usually the one who would be granted an operating license by the regulatory authority having jurisdiction or who has the administrative and operational responsibility for the facility. The owner may be either the operating organization (may not be the actual owner of the physical property of the facility) or the organization that owns and operates the plant.

oxygen cutting: a group of cutting processes wherein the severing of metals is effected by means of the chemical reaction of oxygen with the base metal at elevated temperatures. In the case of oxidation-resistant metals, the reaction is facilitated by use of a flux.

oxygen gouging: an application of oxygen cutting wherein a chamfer or groove is formed.

packaged equipment: an assembly of individual components or stages of equipment, complete with its interconnecting piping and connections for piping external to the equipment assembly. The assembly may be mounted on a skid or other structure prior to delivery.

peening: the mechanical working of metals by means of hammer blows.

pipe and tube: the fundamental difference between pipe and tube is the dimensional standard to which each is manufactured.

A pipe is a tube with a round cross section conforming to the dimensional requirements for nominal pipe size as tabulated in ASME B36.10M, Table 1, and ASME B36.19M, Table 1. For special pipe having a diameter not listed in these Tables, and also for round tube, the nominal diameter corresponds with the outside diameter.

A tube is a hollow product of round or any other cross section having a continuous periphery. Round tube size may be specified with respect to any two, but not all three, of the following: outside diameter, inside diameter, wall thickness; types K, L, and M copper tube may also be specified by nominal size and type only. Dimensions and permissible variations (tolerances) are specified in the appropriate ASTM or ASME standard specifications.

Types of pipe, according to the method of manufacture, are defined as follows:

(A) *electric resistance welded pipe*: pipe produced in individual lengths or in continuous lengths from coiled skelp and subsequently cut into individual lengths, having a longitudinal butt joint wherein coalescence is produced by the heat obtained from resistance of the pipe to the flow of electric current in a circuit of which the pipe is a part, and by the application of pressure.

(B) *furnace butt welded pipe*

(B.1) *furnace butt welded pipe, bell welded*: pipe produced in individual lengths from cut length skelp, having its longitudinal butt joint forge welded by the mechanical pressure developed in drawing the furnace heated skelp through a cone shaped die (commonly known as a “welding bell”) that serves as a combined forming and welding die.

(B.2) *furnace butt welded pipe, continuous welded*: pipe produced in continuous lengths from coiled skelp and subsequently cut into individual lengths, having its longitudinal butt joint forge welded by the mechanical pressure developed in rolling the hot formed skelp through a set of round pass welding rolls.

(C) *electric fusion welded pipe*: pipe having a longitudinal butt joint wherein coalescence is produced in the preformed tube by manual or automatic electric arc welding. The weld may be single (welded from one side), or double (welded from inside and outside) and may be made with or without the use of filler metal. Spiral welded pipe is also made by the electric fusion welded process with either a butt joint, a lap joint, or a lock seam joint.

(D) *electric flash welded pipe*: pipe having a longitudinal butt joint wherein coalescence is produced, simultaneously over the entire area of abutting surfaces, by the heat obtained from resistance to the flow of electric current between the two surfaces, and by the application of pressure after heating is substantially completed. Flashing and upsetting are accompanied by expulsion of metal from the joint.

(E) *double submerged arc welded pipe*: pipe having a longitudinal butt joint produced by the submerged arc process, with at least two passes, one of which is on the inside of the pipe.

(F) *seamless pipe*: pipe produced by one or more of the following processes:

(F.1) *rolled pipe*: pipe produced from a forged billet that is pierced by a conical mandrel between two diametrically opposed rolls. The pierced shell is subsequently rolled and expanded over mandrels of increasingly larger diameter. Where closer dimensional tolerances are desired, the rolled pipe is cold or hot drawn through dies, and machined.

One variation of this process produces the hollow shell by extrusion of the forged billet over a mandrel in a vertical, hydraulic piercing press.

(F.2) *forged and bored pipe*: pipe produced by boring or trepanning of a forged billet.

(F.3) *extruded pipe*: pipe produced from hollow or solid round forgings, usually in a hydraulic extrusion press. In this process the forging is contained in a cylindrical die. Initially a punch at the end of the extrusion plunger pierces the forging. The extrusion plunger then forces the contained billet between the cylindrical die and the punch to form the pipe, the latter acting as a mandrel.

(F.4) *centrifugally cast pipe*: pipe formed from the solidification of molten metal in a rotating mold. Both metal and sand molds are used. After casting, the pipe is machined, to sound metal, on the internal and external diameters to the surface roughness and dimensional requirements of the applicable material specification.

One variation of this process utilizes autofrettage (hydraulic expansion) and heat treatment, above the recrystallization temperature of the material, to produce a wrought structure.

(F.5) *statically cast pipe*: pipe formed by the solidification of molten metal in a sand mold.

pipe supporting elements: pipe supporting elements consist of hangers, supports, and structural attachments.

hangers and supports: hangers and supports include elements that transfer the load from the pipe or structural attachment to the supporting structure or equipment. They include hanging type fixtures, such as hanger rods, spring hangers, sway braces, counterweights, turnbuckles, struts, chains, guides, and anchors, and bearing type fixtures, such as saddles, bases, rollers, brackets, and sliding supports.

structural attachments: structural attachments include elements that are welded, bolted, or clamped to the pipe, such as clips, lugs, rings, clamps, clevises, straps, and skirts.

porosity: cavity-type discontinuities formed by gas entrapment during metal solidification.

postweld heat treatment: see *heat treatments*.

preheating: see *heat treatments*.

pressure: an application of force per unit area; fluid pressure (an application of internal or external fluid force per unit area on the pressure boundary of piping components).

Procedure Qualification Record (PQR): a record of the welding data used to weld a test coupon. The PQR is a record of variables recorded during the welding of the test coupons. It also contains the test results of the tested specimens. Recorded variables normally fall within a small range of the actual variables that will be used in production welding.

qualified (personnel): individuals who have demonstrated and documented abilities gained through training and/or experience that enable them to perform a required function to the satisfaction of the Operating Company.

readily accessible: for visual examination, readily accessible inside surfaces are defined as those inside surfaces that can be examined without the aid of optical devices. (This definition does not prohibit the use of optical devices for a visual examination; however, the selection of the device should be a matter of mutual agreement between the owner and the fabricator or erector.)

Reid vapor pressure: the vapor pressure of a flammable or combustible liquid as determined by ASTM Standard Test Method D323 Vapor Pressure of Petroleum Products (Reid Method).

reinforcement of weld: weld metal on the face of a groove weld in excess of the metal necessary for the specified weld size.

repair: the work necessary to restore pressure-retaining items to a safe and satisfactory operating condition.

restraint: any device that prevents, resists, or limits movement of a piping system.

root opening: the separation between the members to be joined, at the root of the joint.

root penetration: the depth a groove weld extends into the root opening of a joint measured on the centerline of the root cross section.

seal weld: a weld used on a pipe joint primarily to obtain fluid tightness as opposed to mechanical strength.

semiautomatic arc welding: arc welding with equipment that controls only the filler metal feed. The advance of the welding is manually controlled.

shall: "shall" or "shall not" is used to indicate that a provision or prohibition is mandatory.

shielded metal arc welding: an arc welding process wherein coalescence is produced by heating with an electric arc between a covered metal electrode and the work. Shielding is obtained from decomposition of the electrode covering. Pressure is not used and filler metal is obtained from the electrode.

should: “should” or “it is recommended” is used to indicate that a provision is not mandatory but recommended as good practice.

size of weld

fillet weld: for equal leg fillet welds, the leg lengths of the largest isosceles right triangle that can be inscribed within the fillet weld cross section. For unequal leg fillet welds, the leg lengths of the largest right triangle that can be inscribed within the fillet weld cross section.

groove weld: the joint penetration (depth of chamfering plus the root penetration when specified).

slag inclusion: nonmetallic solid material entrapped in weld metal or between weld metal and base metal.

soldering: a metal joining process wherein coalescence is produced by heating to suitable temperature and by using a nonferrous alloy fusible at temperatures below 840°F (450°C) and having a melting point below that of the base metals being joined. The filler metal is distributed between closely fitted surfaces of the joint by capillary action. In general, solders are lead–tin alloys and may contain antimony, bismuth, silver, and other elements.

steel: an alloy of iron and carbon with no more than 2% carbon by weight. Other alloying elements may include manganese, sulfur, phosphorus, silicon, aluminum, chromium, copper, nickel, molybdenum, vanadium, and others depending upon the type of steel. For acceptable material specifications for steel, refer to Chapter III, Materials.

stresses

sustained stress: a stress developed by an imposed loading that is necessary to satisfy the laws of equilibrium between external and internal forces and moments. The basic characteristic of a sustained stress is that it is not self-limiting. If a sustained stress exceeds the yield strength of the material through the entire thickness, the prevention of failure is entirely dependent on the strain-hardening properties of the material. A thermal stress is not classified as a sustained stress. Further, the sustained stresses calculated in this Code are “effective” stresses and are generally lower than those predicted by theory or measured in strain-gage tests.

displacement stress: a stress developed by the self-constraint of the structure. It must satisfy an imposed strain pattern rather than being in equilibrium with an external load. The basic characteristic of a displacement stress is that it is self-limiting. Local yielding and minor distortions can satisfy the displacement or expansion conditions that cause the stress to occur. Failure from one application of the stress is not to be expected. Further, the displacement stresses calculated in this Code are

“effective” stresses and are generally lower than those predicted by theory or measured in strain-gage tests.¹

peak stress: the highest stress in the region under consideration. The basic characteristic of a peak stress is that it causes no significant distortion and is objectionable only as a possible source of a fatigue crack initiation or a brittle fracture. This Code does not utilize peak stress as a design basis, but rather uses effective stress values for sustained stress and for displacement stress; the peak stress effect is combined with the displacement stress effect in the displacement stress range calculation.

stress-relieving: see *heat treatments*.

submerged arc welding: an arc welding process wherein coalescence is produced by heating with an electric arc or arcs between a bare metal electrode or electrodes and the work. The welding is shielded by a blanket of granular, fusible material on the work. Pressure is not used, and filler metal is obtained from the electrode and sometimes from a supplementary welding rod.

supplementary steel: steel members that are installed between existing members for the purpose of installing supports for piping or piping equipment.

swivel joint: a component that permits single-plane rotational movement in a piping system.

tack weld: a weld made to hold parts of a weldment in proper alignment until the final welds are made.

throat of a fillet weld

actual: the shortest distance from the root of a fillet weld to its face.

theoretical: the distance from the beginning of the root of the joint perpendicular to the hypotenuse of the largest right triangle that can be inscribed within the fillet weld cross section.

toe of weld: the junction between the face of the weld and the base metal.

tube: refer to *pipe and tube*.

tungsten electrode: a nonfiller metal electrode used in arc welding, consisting of a tungsten wire.

undercut: a groove melted into the base metal adjacent to the toe of a weld and not filled with weld metal.

visual examination: the observation of whatever portions of components, joints, and other piping elements that are exposed to such observation either before, during, or after manufacture, fabrication, assembly, erection,

¹ Normally, the most significant displacement stress is encountered in the thermal expansion stress range from ambient to the normal operating condition. This stress range is also the stress range usually considered in a flexibility analysis. However, if other significant stress ranges occur, whether they are displacement stress ranges (such as from other thermal expansion or contraction events, or differential support point movements) or sustained stress ranges (such as from cyclic pressure, steam hammer, or earthquake inertia forces), paras. 102.3.2(B) and 104.8.3 may be used to evaluate their effect on fatigue life.

inspection, or testing. This examination may include verification of the applicable requirements for materials, components, dimensions, joint preparation, alignment, welding or joining, supports, assembly, and erection.

weld: a localized coalescence of metal that is produced by heating to suitable temperatures, with or without the application of pressure, and with or without the use of filler metal. The filler metal shall have a melting point approximately the same as the base metal.

welder: one who is capable of performing a manual or semiautomatic welding operation.

Welder/Welding Operator Performance Qualification (WPQ): demonstration of a welder's ability to produce welds in

a manner described in a Welding Procedure Specification that meets prescribed standards.

welding operator: one who operates machine or automatic welding equipment.

Welding Procedure Specification (WPS): a written qualified welding procedure prepared to provide direction for making production welds to Code requirements. The WPS or other documents may be used to provide direction to the welder or welding operator to ensure compliance with the Code requirements.

weldment: an assembly whose component parts are joined by welding.

Chapter II

Design

PART 1 CONDITIONS AND CRITERIA

101 DESIGN CONDITIONS

101.1 General

These design conditions define the pressures, temperatures, and various forces applicable to the design of power piping systems. Power piping systems shall be designed for the most severe condition of coincident pressure, temperature, and loading, except as herein stated. The most severe condition shall be that which results in the greatest required pipe wall thickness and the highest flange rating.

101.2 Pressure

All pressures referred to in this Code are expressed in pounds per square inch and kilopascals above atmospheric pressure, i.e., psig [kPa (gage)], unless otherwise stated.

101.2.2 Internal Design Pressure. The internal design pressure shall be not less than the maximum sustained operating pressure (MSOP) within the piping system including the effects of static head.

101.2.4 External Design Pressure. Piping subject to external pressure shall be designed for the maximum differential pressure anticipated during operating, shut-down, or test conditions.

101.2.5 Pressure Cycling. This Code does not address the contribution to fatigue in fittings and components caused by pressure cycling. Special consideration may be necessary where systems are subjected to a very high number of large pressure cycles.

101.3 Temperature

101.3.1 All temperatures referred to in this Code, unless otherwise stated, are the average metal temperatures of the respective materials expressed in degrees Fahrenheit, i.e., °F (Celsius, i.e., °C).

101.3.2 Design Temperature

(A) The piping shall be designed for a metal temperature representing the maximum sustained condition expected. The design temperature shall be assumed to be the same as the fluid temperature unless calculations or tests support the use of other data, in which case the design temperature shall not be less than the average of the fluid temperature and the outside wall temperature.

(B) Where a fluid passes through heat exchangers in series, the design temperature of the piping in each section of the system shall conform to the most severe temperature condition expected to be produced by the heat exchangers in that section of the system.

(C) For steam, feedwater, and hot water piping leading from fired equipment (such as boiler, reheater, superheater, economizer, etc.), the design temperature shall be based on the expected continuous operating condition plus the equipment manufacturers guaranteed maximum temperature tolerance. For operation at temperatures in excess of this condition, the limitations described in para. 102.2.4 shall apply.

(D) Accelerated creep damage, leading to excessive creep strains and potential pipe rupture, caused by extended operation above the design temperature shall be considered in selecting the design temperature for piping to be operated above 800°F (425°C).

101.4 Ambient Influences

101.4.1 Cooling Effects on Pressure. Where the cooling of a fluid may reduce the pressure in the piping to below atmospheric, the piping shall be designed to withstand the external pressure or provision shall be made to break the vacuum.

101.4.2 Fluid Expansion Effects. Where the expansion of a fluid may increase the pressure, the piping system shall be designed to withstand the increased pressure or provision shall be made to relieve the excess pressure.

101.5 Dynamic Effects

101.5.1 Impact. Impact forces caused by all external and internal conditions shall be considered in the piping design. One form of internal impact force is due to the propagation of pressure waves produced by sudden changes in fluid momentum. This phenomena is often called water or steam "hammer." It may be caused by the rapid opening or closing of a valve in the system. The designer should be aware that this is only one example of this phenomena and that other causes of impact loading exist.

101.5.2 Wind. Exposed piping shall be designed to withstand wind loadings. The analysis considerations and loads may be as described in ASCE/SEI 7, Minimum Design Loads for Buildings and Other Structures. Authoritative local meteorological data may also be

used to define or refine the design wind forces. Where local jurisdictional rules covering the design of building structures are in effect and specify wind loadings for piping, these values shall be considered the minimum design values. Wind need not be considered as acting concurrently with earthquakes.

101.5.3 Earthquake. The effect of earthquakes shall be considered in the design of piping, piping supports, and restraints. The analysis considerations and loads may be as described in ASCE/SEI 7. Authoritative local seismological data may also be used to define or refine the design earthquake forces. Where local jurisdictional rules covering the design of building structures are in effect and specify seismic loadings for piping, these values shall be considered the minimum design values. ASME B31E, Standard for the Seismic Design and Retrofit of Above-Ground Piping Systems, may be used as an alternate method of seismic qualification or for guidance in seismic design. Earthquakes need not be considered as acting concurrently with wind.

101.5.4 Vibration. Piping shall be arranged and supported with consideration of vibration [see paras. 120.1(C) and 121.7.5].

101.6 Weight Effects

The following weight effects combined with loads and forces from other causes shall be taken into account in the design of piping. Piping shall be carried on adjustable hangers or properly leveled rigid hangers or supports, and suitable springs, sway bracing, vibration dampeners, etc., shall be provided where necessary.

101.6.1 Live Load. The live load consists of the weight of the fluid transported. Snow and ice loads shall be considered in localities where such conditions exist.

101.6.2 Dead Load. The dead load consists of the weight of the piping components, insulation, protective lining and coating, and other superimposed permanent loads.

101.6.3 Test or Cleaning Fluid Load. The test or cleaning fluid load consists of the weight of the test or cleaning fluid.

101.7 Thermal Expansion and Contraction Loads

101.7.1 General. The design of piping systems shall take account of the forces and moments resulting from thermal expansion and contraction, and from the effects of expansion joints.

Thermal expansion and contraction shall be provided for preferably by pipe bends, elbows, offsets, or changes in direction of the pipeline.

Hangers and supports shall permit expansion and contraction of the piping between anchors.

101.7.2 Expansion, Swivel, or Ball Joints, and Flexible Metal Hose Assemblies. Joints of the corrugated bellows, slip, sleeve, ball, or swivel types and flexible metal hose assemblies may be used if their materials conform to this Code, their structural and working parts are of ample proportions, and their design prevents the complete disengagement of working parts while in service. In determining expansion joint design criteria, the designer shall give due consideration to conditions of service, including, but not limited to, temperature, pressure, externally imposed displacements, corrosion/erosion, fatigue, and flow velocity.

102 DESIGN CRITERIA

102.1 General

These criteria cover pressure–temperature ratings for standard and specially designed components, allowable stresses, stress limits, and various allowances to be used in the design of piping and piping components.

102.2 Pressure–Temperature Ratings for Piping Components

102.2.1 Components Having Specific Ratings.

Pressure–temperature ratings for certain piping components have been established and are contained in some of the standards listed in Table 126.1.

Where piping components have established pressure–temperature ratings that do not extend to the upper material temperature limits permitted by this Code, the pressure–temperature ratings between those established and the upper material temperature limit may be determined in accordance with the rules of this Code, but such extensions are subject to restrictions, if any, imposed by the standards.

Standard components may not be used at conditions of pressure and temperature that exceed the limits imposed by this Code.

102.2.2 Components Not Having Specific Ratings.

Some of the Standards listed in Table 126.1, such as those for buttwelding fittings, specify that components shall be furnished in nominal thicknesses. Unless limited elsewhere in this Code, such components shall be rated for the same allowable pressures as seamless pipe of the same nominal thickness, as determined in paras. 103 and 104 for material having the same allowable stress.

Piping components, such as pipe, for which allowable stresses have been developed in accordance with para. 102.3, but that do not have established pressure ratings, shall be rated by rules for pressure design in para. 104, modified as applicable by other provisions of this Code.

Should it be desired to use methods of manufacture or design of components not covered by this Code or not listed in referenced standards, it is intended that the manufacturer shall comply with the requirements

of paras. 103 and 104 and other applicable requirements of this Code for design conditions involved. Where components other than those discussed above, such as pipe or fittings not assigned pressure–temperature ratings in an American National Standard, are used, the manufacturer’s recommended pressure–temperature rating shall not be exceeded.

102.2.3 Ratings: Normal Operating Condition. A piping system shall be considered safe for operation if the maximum sustained operating pressure and temperature that may act on any part or component of the system does not exceed the maximum pressure and temperature allowed by this Code for that particular part or component. The design pressure and temperature shall not exceed the pressure–temperature rating for the particular component and material as defined in the applicable specification or standard listed in Table 126.1.

102.2.4 Ratings: Allowance for Variation From Normal Operation. The maximum internal pressure and temperature allowed shall include considerations for occasional loads and transients of pressure and temperature.

It is recognized that variations in pressure and temperature inevitably occur, and therefore the piping system, except as limited by component standards referred to in para. 102.2.1 or by manufacturers of components referred to in para. 102.2.2, shall be considered safe for occasional short operating periods at higher than design pressure or temperature. For such variations, either pressure or temperature, or both, may exceed the design values if the computed circumferential pressure stress does not exceed the maximum allowable stress from Mandatory Appendix A for the coincident temperature by

(A) 15% if the event duration occurs for no more than 8 hr at any one time and not more than 800 hr/yr, or

(B) 20% if the event duration occurs for not more than 1 hr at any one time and not more than 80 hr/yr

102.2.5 Ratings at Transitions. Where piping systems operating at different design conditions are connected, a division valve shall be provided having a pressure–temperature rating equal to or exceeding the more severe conditions. See para. 122 for design requirements pertaining to specific piping systems.

102.3 Allowable Stress Values and Other Stress Limits for Piping Components

102.3.1 Allowable Stress Values

(A) Allowable stress values to be used for the design of power piping systems are given in the Tables in Mandatory Appendix A, also referred to in this Code Section as the Allowable Stress Tables. These tables list allowable stress values for commonly used materials at temperatures appropriate to power piping installations. In every case the temperature is understood to be the

metal temperature. Where applicable, weld joint efficiency factors and casting quality factors are included in the tabulated values. Thus, the tabulated values are values of S , SE , or SF , as applicable.

(B) Allowable stress values in shear shall not exceed 80% of the values determined in accordance with the rules of para. 102.3.1(A). Allowable stress values in bearing shall not exceed 160% of the determined values.

(C) The basis for establishing the allowable stress values in this Code Section are the same as those in the ASME Boiler and Pressure Vessel Code, Section II, Part D, Mandatory Appendix 1; except that allowable stresses for cast iron and ductile iron are in accordance with Section VIII, Division 1, Nonmandatory Appendix P for Tables UCI-23 and UCD-23, respectively.

102.3.2 Limits for Sustained and Displacement Stresses

(A) Sustained Stresses

(A.1) *Internal Pressure Stress.* The calculated stress due to internal pressure shall not exceed the allowable stress values given in the Allowable Stress Tables in Mandatory Appendix A. This criterion is satisfied when the wall thickness of the piping component, including any reinforcement, meets the requirements of paras. 104.1 through 104.7, excluding para. 104.1.3 but including the consideration of allowances permitted by paras. 102.2.4, 102.3.3(B), and 102.4.

(A.2) *External Pressure Stress.* Piping subject to external pressure shall be considered safe when the wall thickness and means of stiffening meet the requirements of para. 104.1.3.

(A.3) *Longitudinal Stress.* The sum of the longitudinal stresses, S_L , due to pressure, weight, and other sustained loads shall not exceed the basic material allowable stress in the hot condition, S_h .

The longitudinal pressure stress, S_{lp} , may be determined by either of the following equations:

$$S_{lp} = \frac{PD_o}{4t_n}$$

or

$$S_{lp} = \frac{Pd_n^2}{D_o^2 - d_n^2}$$

(B) Displacement Stresses

(B.1) *Cyclic Displacement Stress Ranges.* The calculated reference displacement stress range, S_E (see paras. 104.8.3 and 119.6.4), shall not exceed the allowable stress range, S_A , calculated by eq. (1A)

$$S_A = f(1.25S_c + 0.25S_h) \quad (1A)$$

When S_h is greater than S_L , the difference between them may be added to the term $0.25S_h$ in eq. (1A). In

that case, the allowable stress range, S_A , is calculated by eq. (1B)

$$S_A = f(1.25S_c + 1.25S_h - S_L) \quad (1B)$$

where

f = cyclic stress range factor¹ for the total number of equivalent reference displacement stress range cycles, N , determined from eq. (1C)

$$f = 6/N^{0.2} \leq 1.0 \quad (1C)$$

N = total number of equivalent reference displacement stress range cycles expected during the service life of the piping. A minimum value for f is 0.15, which results in an allowable displacement stress range for a total number of equivalent reference displacement stress range cycles greater than 10^8 cycles.

S_c = basic material allowable stress from Mandatory Appendix A at the minimum metal temperature expected during the reference stress range cycle,² psi (kPa)

S_h = basic material allowable stress from Mandatory Appendix A at the maximum metal temperature expected during the reference stress range cycle,² psi (kPa)

In determining the basic material allowable stresses, S_c and S_h , for welded pipe, the joint efficiency factor, E , need not be applied (see para. 102.4.3). The values of the allowable stresses from Mandatory Appendix A may be divided by the joint efficiency factor given for that material. In determining the basic material allowable stresses for castings, the casting quality factor, F , shall be applied (see para. 102.4.6).

When considering more than a single displacement stress range, whether from thermal expansion or other cyclic conditions, each significant stress range shall be computed. The reference displacement stress range, S_E , is defined as the greatest computed displacement stress range. The total number of equivalent reference displacement stress range cycles, N , may then be calculated by eq. (2)

$$N = N_E + \sum(q_i^5 N_i) \text{ for } i = 1, 2, \dots, n \quad (2)$$

where

N_E = number of cycles of the reference displacement stress range, S_E

N_i = number of cycles associated with displacement stress range, S_i

$$q_i = S_i/S_E$$

S_i = any computed stress range other than the reference displacement stress range, psi (kPa)

(B.2) *Noncyclic Displacement Stress Ranges.* Stress ranges caused by noncyclic movements such as those due to settlement or uplift of pipe-supporting structures or components such as buildings, pipe racks, pipe anchors, or rigid supports will not significantly influence fatigue life. Stress ranges caused by such movements may be calculated using eq. (17), replacing S_A with an allowable stress range of $3.0S_c$ and replacing M_c with the moment range due to the noncyclic movement. The stress ranges due to noncyclic displacements need not be combined with cyclic stress ranges in accordance with (B.1) above.

102.3.3 Limits of Calculated Stresses Due to Occasional Loads

(A) *During Operation.* The sum of the longitudinal stresses produced by internal pressure, live and dead loads and those produced by occasional loads, such as the temporary supporting of extra weight, may exceed the allowable stress values given in the Allowable Stress Tables by the amounts and durations of time given in para. 104.8.2.

(B) *During Test.* During pressure tests performed in accordance with para. 137, the circumferential (hoop) stress shall not exceed 90% of the yield strength (0.2% offset) at test temperature. In addition, the sum of longitudinal stresses due to test pressure and live and dead loads at the time of test, excluding occasional loads, shall not exceed 90% of the yield strength at test temperature.

102.4 Allowances

102.4.1 Corrosion or Erosion. When corrosion or erosion is expected, an increase in wall thickness of the piping shall be provided over that required by other design requirements. This allowance in the judgment of the designer shall be consistent with the expected life of the piping.







102.4.2 Threading and Grooving. The calculated minimum thickness of piping (or tubing) that is to be threaded shall be increased by an allowance equal to thread depth; dimension h of ASME B1.20.1 or equivalent shall apply. For machined surfaces or grooves, where the tolerance is not specified, the tolerance shall be assumed to be $\frac{1}{64}$ in. (0.40 mm) in addition to the specified depth of cut. The requirements of para. 104.1.2(C) shall also apply.

102.4.3 Weld Joint Efficiency Factors. The use of joint efficiency factors for welded pipe is required by this Code. The factors in Table 102.4.3 are based on full penetration welds. These factors are included in the

¹ Applies to essentially noncorroded piping. Corrosion can sharply decrease cyclic life; therefore, corrosion-resistant materials should be considered where a large number of significant stress range cycles is anticipated. The designer is also cautioned that the fatigue life of materials operated at elevated temperatures may be reduced.

² For materials with a minimum tensile strength of over 70 ksi (480 MPa), eqs. (1A) and (1B) shall be calculated using S_c or S_h values no greater than 20 ksi (140 MPa), unless otherwise justified.

Table 102.4.3 Longitudinal Weld Joint Efficiency Factors

No.	Type of Joint	Type of Seam	Examination	Factor <i>E</i>
1	Furnace butt weld, continuous weld 	Straight	As required by listed specification	0.60 [Note (1)]
2	Electric resistance weld 	Straight or spiral	As required by listed specification	0.85 [Note (1)]
3	Electric fusion weld			
	(a) Single butt weld (without filler metal) 	Straight or spiral	As required by listed specification Additionally 100% volumetric examination (RT or UT)	0.85 1.00 [Note (2)]
	(b) Single butt weld (with filler metal) 	Straight or spiral	As required by listed specification Additionally 100% volumetric examination (RT or UT)	0.80 1.00 [Note (2)]
	(c) Double butt weld (without filler metal) 	Straight or spiral	As required by listed specification Additionally 100% volumetric examination (RT or UT)	0.90 1.00 [Note (2)]
	(d) Double butt weld (with filler metal) 	Straight or spiral	As required by listed specification Additionally 100% volumetric examination (RT or UT)	0.90 1.00 [Note (2)]
4	API 5L Submerged arc weld (SAW) Gas metal arc weld (GMAW) Combined GMAW, SAW 	Straight with one or two seams Spiral	As required by specification Additionally 100% volumetric examination (RT or UT)	0.90 1.00 [Note (2)]

NOTES:

- (1) It is not permitted to increase the longitudinal weld joint efficiency factor by additional examination for joint 1 or 2.
- (2) RT (radiographic examination) shall be in accordance with the requirements of para. 136.4.5 or the material specification, as applicable. UT (ultrasonic examination) shall be in accordance with the requirements of para. 136.4.6 or the material specification, as applicable.

Table 102.4.5 Bend Thinning Allowance

Radius of Bends	Minimum Thickness Recommended Prior to Bending
6 pipe diameters or greater	$1.06t_m$
5 pipe diameters	$1.08t_m$
4 pipe diameters	$1.14t_m$
3 pipe diameters	$1.25t_m$

GENERAL NOTES:

- (a) Interpolation is permissible for bending to intermediate radii.
 (b) t_m is determined by eq. (7) or (8) of para. 104.1.2(A).
 (c) Pipe diameter is the nominal diameter as tabulated in ASME B36.10M, Tables 1, and ASME B36.19M, Table 1. For piping with a diameter not listed in these Tables, and also for tubing, the nominal diameter corresponds with the outside diameter.

allowable stress values given in Mandatory Appendix A. The factors in Table 102.4.3 apply to both straight seam and spiral seam welded pipe.

102.4.4 Mechanical Strength. Where necessary for mechanical strength to prevent damage, collapse, excessive sag, or buckling of pipe due to superimposed loads from supports or other causes, the wall thickness of the pipe should be increased; or, if this is impractical or would cause excessive local stresses, the superimposed loads or other causes shall be reduced or eliminated by other design methods. The requirements of para. 104.1.2(C) shall also apply.

102.4.5 Bending. The minimum wall thickness at any point on the bend shall conform to (A) or (B) below.

(A) The minimum wall thickness at any point in a completed bend shall not be less than required by eq. (7) or (8) of para. 104.1.2(A).

(A.1) Table 102.4.5 is a guide to the designer who must specify wall thickness for ordering pipe. In general, it has been the experience that when good shop practices are employed, the minimum thicknesses of straight pipe shown in Table 102.4.5 should be sufficient for bending and still meet the minimum thickness requirements of para. 104.1.2(A).

(A.2) The bend thinning allowance in Table 102.4.5 may be provided in all parts of the cross section of the pipe circumference without any detrimental effects being produced.

(B) The minimum required thickness, t_m , of a bend, after bending, in its finished form, shall be determined in accordance with eq. (3) or (4)

$$t_m = \frac{PD_o}{2(SE/I + Py)} + A \quad (3)$$

or

$$t_m = \frac{Pd + 2SEA/I + 2yPA}{2(SE/I + Py - P)} \quad (4)$$

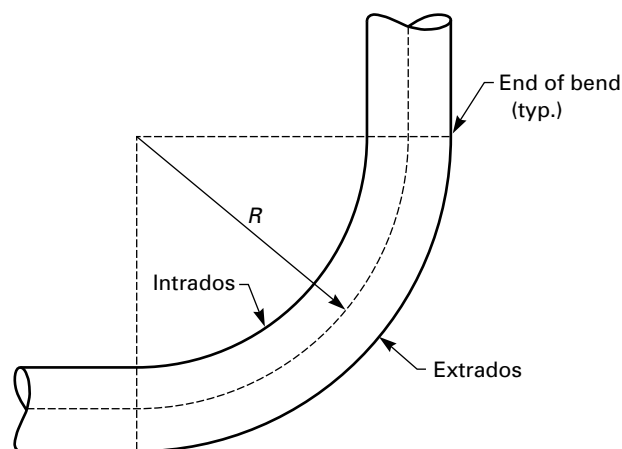
Fig. 102.4.5 Nomenclature for Pipe Bends

where at the intrados (inside of bend)

$$I = \frac{4(R/D_o) - 1}{4(R/D_o) - 2} \quad (5)$$

and at the extrados (outside of bend)

$$I = \frac{4(R/D_o) + 1}{4(R/D_o) + 2} \quad (6)$$

and at the sidewall on the bend centerline

$$I = 1.0$$

where

R = bend radius of pipe bend

Thickness variations from the intrados to the extrados and at the ends of the bend shall be gradual. The thickness requirements apply at the center of the bend arc, at the intrados, extrados, and bend centerline (see Fig. 102.4.5). The minimum thickness at the ends of the bends shall not be less than the requirements of para. 104.1.2 for straight pipe. For bends to conform to this paragraph, all thickness requirements must be met.

102.4.6 Casting Quality Factors

(16)

(A) *General.* Except for gray iron castings, the use of a casting quality factor is required for all cast components that use the allowable stress values of Mandatory Appendix A as the design basis. The factor, 0.80 for castings and 0.85 for centrifugally cast pipe, is included in the allowable stress values given in Mandatory Appendix A.

This required factor does not apply to component standards listed in Table 126.1, if such standards define allowable pressure-temperature ratings or provide the allowable stresses to be used as the design basis for the component.

Table 102.4.6(B.1.1) Maximum Severity Level for Casting Thickness 4½ in. (114 mm) or Less

Discontinuity Category Designation	Severity Level		Discontinuity Category Designation	Severity Level
	≤1 in. (25 mm) Thick	>1 in. (25 mm) Thick		
For E446 [Castings up to 2 in. (50 mm) Thickness]			For E186 [Castings 2 in. to 4½ in. (50 mm to 114 mm) Thickness]	
A	1	2	A, B, and Types 1 and 2 of C	2
B	2	3	Type 3 of C	3
C Types 1, 2, 3, and 4	1	3	D, E, and F	None acceptable
D, E, F, and G	None acceptable	None acceptable		

(B) For steel materials, a casting quality factor not exceeding 1.0 may be applied when the following requirements are met:

(B.1) All steel castings having a nominal body thickness of 4½ in. (114 mm) or less (other than pipe flanges, flanged valves and fittings, and butt welding end valves, all complying with ASME B16.5 or B16.34) shall be inspected visually (MSS SP-55 may be used for guidance) as follows:

(B.1.1) All critical areas, including the junctions of all gates, risers, and abrupt changes in section or direction and area of weld end preparation shall be volumetrically examined in accordance with Section V of the ASME Boiler and Pressure Vessel Code. Radiographs shall conform to the requirements of ASTM E446, Reference Radiographs for Steel Castings up to 2 in. (50 mm) in Thickness, or ASTM E186, Reference Radiographs for Heavy Walled (2 to 4½ in. [50 to 114 mm]) Steel Castings, depending upon the section thickness. MSS SP-54 may be used for guidance. The maximum acceptable severity level for a 1.0 quality factor shall be as listed in Table 102.4.6(B.1.1). Where appropriate, radiographic examination (RT) of castings may be supplemented or replaced with ultrasonic examination (UT), provided it is performed in accordance with MSS SP-94.

(B.1.2) All surfaces of each casting, including machined gasket seating surfaces, shall be examined by the magnetic particle or dye penetrant method after heat treatment. The examination techniques shall be in accordance with Article 6 or 7, as applicable, and Article 9 of Section V of the ASME Boiler and Pressure Vessel Code. MSS SP-53 and SP-93 may be used for guidance. Magnetic particle or dye penetrant indications exceeding degree 1 of Type I, degree 2 of Type II, and degree 3 of Type III, and exceeding degree 1 of Types IV and V of ASTM E125, Standard Reference Photographs for Magnetic Particle Indications on Ferrous Castings, are not acceptable and shall be removed.

(B.1.3) Where more than one casting of a particular design is produced, each of the first five castings shall be inspected as above. Where more than five castings are being produced, the examination shall be performed on the first five plus one additional casting to represent each five additional castings. If this additional casting proves to be unacceptable, each of the remaining castings in the group shall be inspected.

(B.1.4) Any discontinuities in excess of the maximum permitted in (B.1.1) and (B.1.2) above shall be removed, and the casting may be repaired by welding after the base metal has been inspected to ensure complete removal of discontinuities. [Refer to para. 127.4.11(A).] The complete 4d repair shall be subject to reinspection by the same method as was used in the original inspection and shall be reinspected after any required postweld heat treatment.

(B.2) All steel castings having a nominal body thickness greater than 4½ in. (114 mm) (other than pipe flanges, flanged valves and fittings, and butt welding end valves, all complying with ASME B16.5 or B16.34) shall be inspected visually (MSS SP-55 may be used for guidance) as follows:

(B.2.1) All surfaces of each casting including machined gasket seating surfaces, shall be examined by the magnetic particle or dye penetrant method after heat treatment. The examination techniques shall be in accordance with Article 6 or 7, as applicable, and with Article 9 of Section V of the ASME Boiler and Pressure Vessel Code. Magnetic particle or dye penetrant indications exceeding degree 1 of Type I, degree 2 of Type II, degree 3 of Type III, and degree 1 of Types IV and V of ASTM E125, Standard Reference Photographs for Magnetic Particle Indications on Ferrous Castings, shall be removed.

(B.2.2) All parts of castings shall be subjected to complete volumetric examination (RT or UT) in accordance with Section V of the ASME Boiler and Pressure

Table 102.4.6(B.2.2) Maximum Severity Level for Casting Thickness Greater Than 4½ in. (114 mm)

Discontinuity Category Designation	Severity Level
A, B, and Types 1, 2, and 3 of C	2
D, E, and F	None acceptable

Vessel Code. Radiographs shall conform to the requirements of ASTM E280.

The maximum acceptable severity level for a 1.0 quality factor shall be as listed in Table 102.4.6(B.2.2). MSS SP-54 may be used for guidance. Where appropriate, radiographic examination (RT) of castings may be supplemented or replaced with ultrasonic examination (UT), provided it is performed in accordance with MSS SP-94.

(B.2.3) Any discontinuities in excess of the maximum permitted in (B.2.1) and (B.2.2) above shall be removed and may be repaired by welding after the base metal has been magnetic particle or dye penetrant inspected to ensure complete removal of discontinuities. [Refer to para. 127.4.11(A).]

(B.2.4) All weld repairs of depth exceeding 1 in. (25 mm) or 20% of the section thickness, whichever is the lesser, shall be inspected by volumetric examination (RT or UT) in accordance with (B.2.2) above and by magnetic particle or dye penetrant inspection of the finished weld surface. All weld repairs of depth less than 20% of the section thickness, or 1 in. (25 mm), whichever is the lesser, and all weld repairs of section that cannot be effectively radiographed shall be examined by magnetic particle or dye penetrant inspection of the first layer, of each ¼ in. (6 mm) thickness of deposited weld metal, and of the finished weld surface. Magnetic particle or dye penetrant testing of the finished weld surface shall be done after postweld heat treatment.

(C) For cast iron and nonferrous materials, no increase of the casting quality factor is allowed except when special methods of examination, prescribed by the material specification, are followed. If such increase is specifically permitted by the material specification, a factor not exceeding 1.0 may be applied.

102.4.7 Weld Strength Reduction Factors. At elevated temperatures, seam welds on longitudinal-welded or spiral-welded pipe can have lower creep strength than the base material. This reduction is a factor in determining the minimum wall thickness for longitudinal-welded or spiral-welded pipe (i.e., not seamless), whether fabricated in accordance with a material specification or fabricated in accordance with the rules of this Code. The weld strength reduction factor, W , is given

in Table 102.4.7. The designer is responsible to assess application of weld strength reduction factor requirements for welds other than longitudinal and spiral, as applicable (e.g., circumferential welds).

PART 2

PRESSURE DESIGN OF PIPING COMPONENTS

103 CRITERIA FOR PRESSURE DESIGN OF PIPING COMPONENTS

The design of piping components shall consider the effects of pressure and temperature, in accordance with paras. 104.1 through 104.7, including the consideration of allowances permitted by paras. 102.2.4 and 102.4. In addition, the mechanical strength of the piping system shall be determined adequate in accordance with para. 104.8 under other applicable loadings, including but not limited to those loadings defined in para. 101.

104 PRESSURE DESIGN OF COMPONENTS

104.1 Straight Pipe

104.1.1 Straight Pipe Under Internal Pressure.

Straight pipe under internal pressure shall have a minimum wall thickness calculated per para. 104.1.2 if the pipe is of seamless construction or is designed for sustained operation below the creep range. Straight pipe under internal pressure shall have a minimum wall thickness calculated per para. 104.1.4 if the pipe is of longitudinal-welded or spiral-welded construction designed for sustained operation within the creep range. (See para. 123.4 for definition of the creep range.)

104.1.2 Straight Pipe Under Internal Pressure — (16) Seamless, Longitudinal Welded, or Spiral Welded and Operating Below the Creep Range

(A) *Minimum Wall Thickness.* The minimum thickness of pipe wall required for design pressures and for temperatures not exceeding those for the various materials listed in the Allowable Stress Tables, including allowances for mechanical strength, shall not be less than that determined by eq. (7) or (8), as follows:

$$t_m = \frac{PD_o}{2(SE + Py)} + A \quad (7)^3$$

$$t_m = \frac{Pd + 2SEA + 2yPA}{2(SE + Py - P)} \quad (8)^3$$

Design pressure shall not exceed

$$P = \frac{2SE(t_m - A)}{D_o - 2y(t_m - A)} \quad (9)^3$$

³ SF shall be used in place of SE where casting quality factors are intended. See definition of SE . Units of P and SE must be identical. Mandatory Appendix A values must be converted to kPa when the design pressure is in kPa.

Table 102.4.7 Weld Strength Reduction Factors to Be Applied When Calculating the Minimum Wall Thickness or Allowable Design Pressure of Components Fabricated With a Longitudinal Seam Fusion Weld

Steel Group	Weld Strength Reduction Factor for Temperature, °F (°C) [Notes (1)–(7)]										
	700 (371)	750 (399)	800 (427)	850 (454)	900 (482)	950 (510)	1,000 (538)	1,050 (566)	1,100 (593)	1,150 (621)	1,200 (649)
CrMo [Notes (8), (9), (10)]	1.00	0.95	0.91	0.86	0.82	0.77	0.73	0.68	0.64
CSEF (N+T) [Notes (8), (11), (12)]	1.00	0.95	0.91	0.86	0.82	0.77
CSEF (Sub Crit) [Notes (8), (13)]	1.00	0.50	0.50	0.50	0.50	0.50	0.50
Austenitic stainless (incl. 800H & 800HT) [Notes (14), (15)]	1.00	0.95	0.91	0.86	0.82	0.77
Autogenously welded austenitic stainless [Note (16)]	1.00	1.00	1.00	1.00	1.00	1.00

NOTES:

- (1) NP = not permitted.
- (2) Longitudinal welds in pipe for materials not covered in this Table operating in the creep regime are not permitted. For the purposes of this Table, the start of the creep range is the highest temperature where the nonitalicized stress values end in Mandatory Appendix A for the base material involved.
- (3) All weld filler metal shall be a minimum of 0.05% C for CrMo and CSEF materials, and 0.04% C for austenitic stainless in this Table.
- (4) Materials designed for temperatures below the creep range [see Note (2)] may be used without consideration of the WSRF or the rules of this Table. All other Code rules apply.
- (5) Longitudinal seam welds in CrMo and CSEF materials shall be subjected to, and pass, a 100% volumetric examination (RT or UT). For materials other than CrMo and CSEF, see para. 123.4(B).
- (6) At temperatures below those where WSRFs are tabulated, a value of 1.0 shall be used for the factor *W* where required by the rules of this Section. However, the additional rules of this Table and Notes do not apply.
- (7) Carbon steel pipes and tubes are exempt from the requirements of para. 102.4.7 and Table 102.4.7.
- (8) Basicity index of SAW flux ≥ 1.0 .
- (9) The CrMo steels include $\frac{1}{2}\text{Cr}-\frac{1}{2}\text{Mo}$, $1\text{Cr}-\frac{1}{2}\text{Mo}$, $1\frac{1}{4}\text{Cr}-\frac{1}{2}\text{Mo}-\text{Si}$, $2\frac{1}{4}\text{Cr}-1\text{Mo}$, $3\text{Cr}-1\text{Mo}$, and $5\text{Cr}-\frac{1}{2}\text{Mo}$. Longitudinal welds shall either be normalized, normalized and tempered, or subjected to proper subcritical PWHT for the alloy.
- (10) Longitudinal seam fusion welded construction is not permitted for $\text{C}-\frac{1}{2}\text{Mo}$ steel for operation in the creep range [see Notes (2) and (4)].
- (11) The CSEF (creep strength enhanced ferritic) steels include Grades 91, 92, 911, 122, and 23.
- (12) N+T = normalizing + tempering PWHT.
- (13) Sub Crit = subcritical PWHT is required. No exemptions from PWHT are permitted. The PWHT time and temperature shall meet the requirements of Table 132; the alternate PWHT requirements of Table 132.1 are not permitted.
- (14) WSRFs have been assigned for austenitic stainless (including 800H and 800HT) longitudinally welded pipe up to 1,500°F as follows:

Temperature, °F	Temperature, °C	Weld Strength Reduction Factor
1,250	677	0.73
1,300	704	0.68
1,350	732	0.64
1,400	760	0.59
1,450	788	0.55
1,500	816	0.5

- (15) Certain heats of the austenitic stainless steels, particularly for those grades whose creep strength is enhanced by the precipitation of temper-resistant carbides and carbo-nitrides, can suffer from an embrittlement condition in the weld heat affected zone that can lead to premature failure of welded components operating at elevated temperatures. A solution annealing heat treatment of the weld area mitigates this susceptibility.
- (16) Autogenous SS welded pipe (without weld filler metal) has been assigned a WSRF up to 1,500°F of 1.00, provided that the product is solution annealed after welding and receives nondestructive electric examination, in accordance with the material specification.

$$P = \frac{2SE(t_m - A)}{d - 2y(t_m - A) + 2t_m} \quad (10)^3$$

where the nomenclature used above is

(A.1) t_m = minimum required wall thickness, in. (mm)

(A.1.1) If pipe is ordered by its nominal wall thickness, the manufacturing tolerance on wall thickness must be taken into account. After the minimum pipe wall thickness t_m is determined by eq. (7) or (8), this minimum thickness shall be increased by an amount sufficient to provide the manufacturing tolerance allowed in the applicable pipe specification or required by the process. The next heavier commercial wall thickness shall then be selected from thickness schedules such as contained in ASME B36.10M or from manufacturers' schedules for other than standard thickness.

(A.1.2) To compensate for thinning in bends, refer to para. 102.4.5.

(A.1.3) For cast piping components, refer to para. 102.4.6.

(A.1.4) Where ends are subject to forming or machining for jointing, the wall thickness of the pipe, tube, or component after such forming or machining shall not be less than t_m minus the amount provided for removal by para. 104.1.2 (A.6.1).

(A.2) P = internal design pressure, psig [kPa (gage)]

NOTE: When computing the design pressure for a pipe of a definite minimum wall thickness by eq. (9) or (10), the value of P obtained by these formulas may be rounded out to the next higher unit of 10. For cast iron pipe, see para. 104.1.2(B).

(A.3) D_o = outside diameter of pipe, in. (mm). For design calculations, the outside diameter of pipe as given in tables of standards and specifications shall be used in obtaining the value of t_m . When calculating the allowable working pressure of pipe on hand or in stock, the actual measured outside diameter and actual measured minimum wall thickness at the thinner end of the pipe may be used to calculate this pressure.

(A.4) d = inside diameter of pipe, in. (mm). For design calculations, the inside diameter of pipe is the maximum possible value allowable under the purchase specification. When calculating the allowable working pressure of pipe on hand or in

stock, the actual measured inside diameter and actual measured minimum wall thickness at the thinner end of the pipe may be used to calculate this pressure.

(A.5) SE

or SF = maximum allowable stress in material due to internal pressure and joint efficiency (or casting quality factor) at the design temperature, psi (MPa). The value of SE or SF shall not exceed that given in Mandatory Appendix A, for the respective material and design temperature. These values include the weld joint efficiency, E , or the casting factor, F .

(A.6) A = additional thickness, in. (mm)

(A.6.1) To compensate for material removed in threading, grooving, etc., required to make a mechanical joint, refer to para. 102.4.2.

(A.6.2) To provide for mechanical strength of the pipe, refer to para. 102.4.4 (not intended to provide for extreme conditions of misapplied external loads or for mechanical abuse).

(A.6.3) To provide for corrosion and/or erosion, refer to para. 102.4.1.

(A.7) y = coefficient having values as given in Table 104.1.2(A)

(B) Thickness of gray and ductile iron fittings conveying liquids may be determined from ANSI/AWWA C110/A21.10 or ANSI/AWWA C153/A21.53. The thickness of ductile iron pipe may be determined by ANSI/AWWA C115/A21.15 or ANSI/AWWA C150/A21.50. These thicknesses include allowances for foundry tolerances and water hammer.

(C) While the thickness determined from eq. (7) or (8) is theoretically ample for both bursting pressure and material removed in threading, the following minimum requirements are mandatory to furnish added mechanical strength:

(C.1) Where steel pipe is threaded and used for steam service at pressure above 250 psi (1 750 kPa) or for water service above 100 psi (700 kPa) with water temperature above 220°F (105°C), the pipe shall be seamless having the minimum ultimate tensile strength of 48,000 psi (330 MPa) and a weight at least equal to Schedule 80 of ASME B36.10M.

(C.2) Where threaded brass or copper pipe is used for the services described in (C.1) above, it shall comply with pressure and temperature classifications permitted for these materials by other paragraphs of this Code and shall have a wall thickness at least equal to that specified above for steel pipe of corresponding size.

(16)

Table 104.1.2(A) Values of y

Material	Temperature, °F (°C)							
	900 (482) and Below	950 (510)	1,000 (538)	1,050 (566)	1,100 (593)	1,150 (621)	1,200 (649)	1,250 (677) and Above
Ferritic steels	0.4	0.5	0.7	0.7	0.7	0.7	0.7	0.7
Austenitic steels	0.4	0.4	0.4	0.4	0.5	0.7	0.7	0.7
Nickel alloy UNS No. N06690	0.4	0.4	0.4	0.4	0.5	0.7	0.7	...
Nickel alloys UNS Nos. N06617, N08800, N08810, N08825	0.4	0.4	0.4	0.4	0.4	0.4	0.5	0.7
Cast iron	0.0
Other metals [Note (1)]	0.4	0.4	0.4	0.4	0.4	0.4	0.4	0.4

GENERAL NOTES:

- (a) The value of y may be interpolated between the 50°F (27.8°C) incremental values shown in the Table.
- (b) For pipe with a D_o/t_m ratio less than 6, the value of y for ferritic and austenitic steels designed for temperatures of 900°F (480°C) and below shall be taken as

$$y = \frac{d}{d + D_o}$$

NOTE:

- (1) Metals listed in Mandatory Appendix A that are not covered by the categories of materials listed above.

(C.3) Plain end nonferrous pipe or tube shall have minimum wall thicknesses as follows:

(C.3.1) For nominal sizes smaller than NPS $\frac{3}{4}$ (DN 20), the thickness shall not be less than that specified for Type K of ASTM B88.

(C.3.2) For nominal sizes NPS $\frac{3}{4}$ (DN 20) and larger, the wall thickness shall not be less than 0.049 in. (1.25 mm). The wall thickness shall be further increased, as required, in accordance with para. 102.4.

104.1.3 Straight Pipe Under External Pressure. For determining wall thickness and stiffening requirements for straight pipe under external pressure, the procedures outlined in UG-28, UG-29, and UG-30 of Section VIII, Division 1 of the ASME Boiler and Pressure Vessel Code shall be followed.

104.1.4 Longitudinal-Welded or Spiral-Welded Pipe Operating in the Creep Range. The minimum thickness of pipe wall required for design pressures and for temperature not exceeding that for the various materials listed in the Allowable Stress Tables shall not be less than that determined by eq. (11) or (12) as follows:

$$t_m = \frac{PD_o}{2(SEW + Py)} + A \quad (11)$$

$$t_m = \frac{Pd + 2SEWA + 2yPA}{2(SEW + Py - P)} \quad (12)$$

Design pressure shall not exceed

$$P = \frac{2SEW(t_m - A)}{D_o - 2y(t_m - A)}$$

$$P = \frac{2SEW(t_m - A)}{d - 2y(t_m - A) + 2t_m}$$

where the nomenclature used above is given in para. 104.1.2 and

E = weld joint efficiency factor (as given in Table 102.4.3 and referenced in Mandatory Appendix A tables)

SE = maximum allowable stress in material due to internal pressure and joint efficiency at the design temperature, psi (MPa). The value of SE shall not exceed that given in Mandatory Appendix A, for the respective material and design temperature. These values include the weld joint efficiency factor, E .

W = weld strength reduction factor (see para. 102.4.7)

Also see requirements in para. 123.4 and Table 102.4.3.

104.2 Curved Segments of Pipe

104.2.1 Pipe Bends. Pipe bends shall be subject to the following limitations:

(A) The minimum wall thickness shall meet the requirements of para. 102.4.5 and the fabrication requirements of para. 129.

(B) Limits on flattening and buckling at bends may be specified by design, depending upon the service, the material, and the stress level involved. Where limits on flattening and buckling are not specified by design, the requirements of para. 129.1 shall be met.

104.2.2 Elbows. Elbows manufactured in accordance with the standards listed in Table 126.1 are suitable for use at the pressure–temperature ratings specified by such standards, subject to the requirements of para. 106.

104.3 Intersections

(16) 104.3.1 Branch Connections

(A) This paragraph gives rules governing the design of branch connections to sustain internal and external pressure in cases where the axes of the branch and the run intersect, and the angle between the axes of the branch and of the run is between 45 deg and 90 deg, inclusive.

Branch connections in which the smaller angle between the axes of the branch and the run is less than 45 deg or branch connections where the axes of the branch and the run do not intersect impose special design and fabrication problems. The rules given herein may be used as a guide, but sufficient additional strength must be provided to ensure safe service. Such branch connections shall be designed to meet the requirement of para. 104.7.

(B) Branch connections in piping may be made from materials listed in Mandatory Appendix A by the use of the following:

(B.1) fittings, such as tees, laterals, and crosses made in accordance with the applicable standards listed in Table 126.1 where the attachment of the branch pipe to the fitting is by butt welding, socket welding, brazing, soldering, threading, or by a flanged connection.

(B.2) weld outlet fittings, such as cast or forged nozzles, couplings and adaptors, or similar items where the attachment of the branch pipe to the fitting is by butt welding, socket welding, threading, or by a flanged connection. Such weld outlet fittings are attached to the run by welding similar to that shown in Fig. 127.4.8(E) or Fig. 127.4.8(F), as applicable. MSS SP-97 may be used for design and manufacturing standards for integrally reinforced forged branch outlet fittings. Couplings are restricted to a maximum of NPS 3 (DN 80).

(B.3) extruded outlets at right angles to the run pipe, in accordance with (G) below, where the attachment of the branch pipe is by butt welding.

(B.4) piping directly attached to the run pipe by welding in accordance with para. 127.4.8 or by socket welding or threading as stipulated below.

(B.4.1) socket welded right angle branch connections may be made by attaching the branch pipe directly to the run pipe provided

(B.4.1.1) the nominal size of the branch does not exceed NPS 2 (DN 50) or one-fourth of the nominal size of the run, whichever is smaller.

(B.4.1.2) the depth of the socket measured at its minimum depth in the run pipe is at least equal to that shown in ASME B16.11. If the run pipe wall does

not have sufficient thickness to provide the proper depth of socket, an alternate type of construction shall be used.

(B.4.1.3) the clearance between the bottom of the socket and the end of the inserted branch pipe is in accordance with Fig. 127.4.4(C).

(B.4.1.4) the size of the fillet weld is not less than 1.09 times the nominal wall thickness of the branch pipe.

(B.4.2) threaded right angle branch connections may be made by attaching the branch pipe directly to the run provided

(B.4.2.1) the nominal size of the branch does not exceed NPS 2 (DN 50) or one-fourth of the nominal size of the run, whichever is smaller.

(B.4.2.2) the minimum thread engagement is six full threads for NPS $\frac{1}{2}$ (DN 15) and NPS $\frac{3}{4}$ (DN 20) branches; seven for NPS 1 (DN 25), NPS $1\frac{1}{4}$ (DN 32), and NPS $1\frac{1}{2}$ (DN 40) branches; and eight for NPS 2 (DN 50) branches. If the run pipe wall does not have sufficient thickness to provide the proper depth for thread engagement, an alternative type of construction shall be used.

(C) *Branch Connections Not Requiring Reinforcement.* A pipe having a branch connection is weakened by the opening that must be made in it. Unless the wall thickness of the branch and/or run pipe is sufficiently in excess of that required to sustain the pressure, it is necessary to provide additional material to meet the reinforcement requirements of (D) and (E) below. However, there are certain branch connections for which supporting calculations are not required. These are as follows:

(C.1) branch connections made by the use of a fitting (tee, lateral, cross, or branch weld-on fitting), manufactured in accordance with a standard listed in Table 126.1, and used within the limits of pressure–temperature ratings specified in that standard.

(C.2) branch connections made by welding a coupling or half coupling directly to the run pipe in accordance with Fig. 127.4.8(F), provided the nominal diameter of the branch does not exceed NPS 2 (DN 50) or one-fourth the nominal diameter of the run, whichever is less. The minimum wall thickness of the coupling anywhere in the reinforcement zone (if threads are in the zone, wall thickness is measured from the root of the thread to the minimum O.D.) shall not be less than that of the unthreaded branch pipe. In no case shall the thickness of the coupling be less than extra heavy or Class 3000 rating.

Small branch connections NPS 2 (DN 50) or smaller as shown in Fig. 127.4.8(G) may be used, provided t_w is not less than the thickness of schedule 160 pipe of the branch size.

(C.3) integrally reinforced fittings welded directly to the run pipe when the reinforcements provided by the fitting and the deposited weld metal meets the requirements of (D) below.

(C.4) integrally reinforced extruded outlets in the run pipe. The reinforcement requirements shall be in accordance with (G) below.

(D) Branch Connections Subject to Internal Pressure Requiring Reinforcement

(D.1) Reinforcement is required when it is not provided inherently in the components of the branch connection. This paragraph gives rules covering the design of branch connections to sustain internal pressure in cases where the angle between the axes of the branch and of the run is between 45 deg and 90 deg. Subparagraph (E) below gives rules governing the design of connections to sustain external pressure.

(D.2) Figure 104.3.1(D) illustrates the notations used in the pressure–temperature design conditions of branch connections. These notations are as follows:

- b = subscript referring to branch
- D_{ob} = outside diameter of branch, in. (mm)
- D_{oh} = outside diameter of header, in. (mm)
- d_1 = inside centerline longitudinal dimension of the finished branch opening in the run of the pipe, in. (mm)
= $[D_{ob} - 2(T_b - A)]/\sin \alpha$
- d_2 = “half width” of reinforcing zone, in. (mm)
= the greater of d_1 or $(T_b - A) + (T_h - A) + d_1/2$ but in no case more than D_{oh} , in. (mm)
- h = subscript referring to run or header
- L_4 = altitude of reinforcement zone outside of run, in. (mm)
= $2.5(T_b - A) + t_r$ or $2.5(T_h - A)$, whichever is smaller
- T_b, T_h = actual wall thickness (by measurement) or the minimum wall thickness permissible under the purchase specification of the branch or header pipe, in. (mm)
- t_{mb}, t_{mh} = required minimum wall thickness, in. (mm), of the branch or header pipe as determined by use of eq. (7) or (8) in para. 104.1.2(A)
- t_r = thickness of attached reinforcing pad, in Example A, in. (mm); or height of the largest 60 deg right triangle supported by the run and branch outside diameter projected surfaces and lying completely within the area of integral reinforcement, in Example B, in. (mm)
- α = angle between axes of branch and run, deg

(D.2.1) If the run pipe contains a longitudinal seam that is not intersected by the branch, the stress value of seamless pipe of comparable grade may be used to determine the value of t_{mh} for the purpose of reinforcement calculations only. If the branch intersects a longitudinal weld in the run, or if the branch contains a weld, the weld joint efficiency for either or both shall enter the calculations. If the branch and run both contain

longitudinal welds, care shall be taken to ensure that the two welds do not intersect each other.

(D.2.2) The required reinforcement area in square inches (square millimeters) for branch connections shall be the quantity

$$A_7 = A_6(2 - \sin \alpha) = (t_{mh} - A)d_1(2 - \sin \alpha)$$

For right angle connections, the required reinforcement becomes

$$A_7 = A_6 = (t_{mh} - A)d_1$$

The required reinforcement must be within the limits of the reinforcement zone as defined in (D.2.4) below.

(D.2.3) The reinforcement required by (D.2) shall be that provided by any combination of areas $A_1, A_2, A_3, A_4,$ and $A_5,$ as defined below and illustrated in Fig. 104.3.1(D) where

- A_1 = area provided by excess pipe wall in the run
= $(2d_2 - d_1)(T_h - t_{mh})$
- A_2 = area, in.² (mm²), provided by excess pipe wall in the branch for a distance L_4 above the run
= $2L_4(T_b - t_{mb})/\sin \alpha$
- A_3 = area provided by deposited weld metal beyond the outside diameter of the run and branch, and for fillet weld attachments of rings, pads, and saddles
- A_4 = area provided by a reinforcing ring, pad, or integral reinforcement. The value of A_4 may be taken in the same manner in which excess header metal is considered, provided the weld completely fuses the branch pipe, run pipe, and ring or pad, or integral reinforcement. For welding branch connections refer to para. 127.4.8.
- A_5 = area provided by a saddle on right angle connections
= (O.D. of saddle - D_{ob}) t_r
- A_6 = pressure design area expected at the end of service life
= $(t_{mh} - A)d_1$

Portions of the reinforcement area may be composed of materials other than those of the run pipe, but if the allowable stress of these materials is less than that for the run pipe, the corresponding calculated reinforcement area provided by this material shall be reduced in the ratio of the allowable stress being applied to the reinforcement area. No additional credit shall be taken for materials having higher allowable stress values than the run pipe.

(D.2.4) *Reinforcement Zone.* The reinforcement zone is a parallelogram whose width shall extend a distance d_2 on each side of the centerline of the branch pipe, and whose altitude shall start at the inside surface of the run pipe and extend to a distance L_4 from the outside surface of the run pipe.

Fig. 104.3.1(D) Reinforcement of Branch Connections

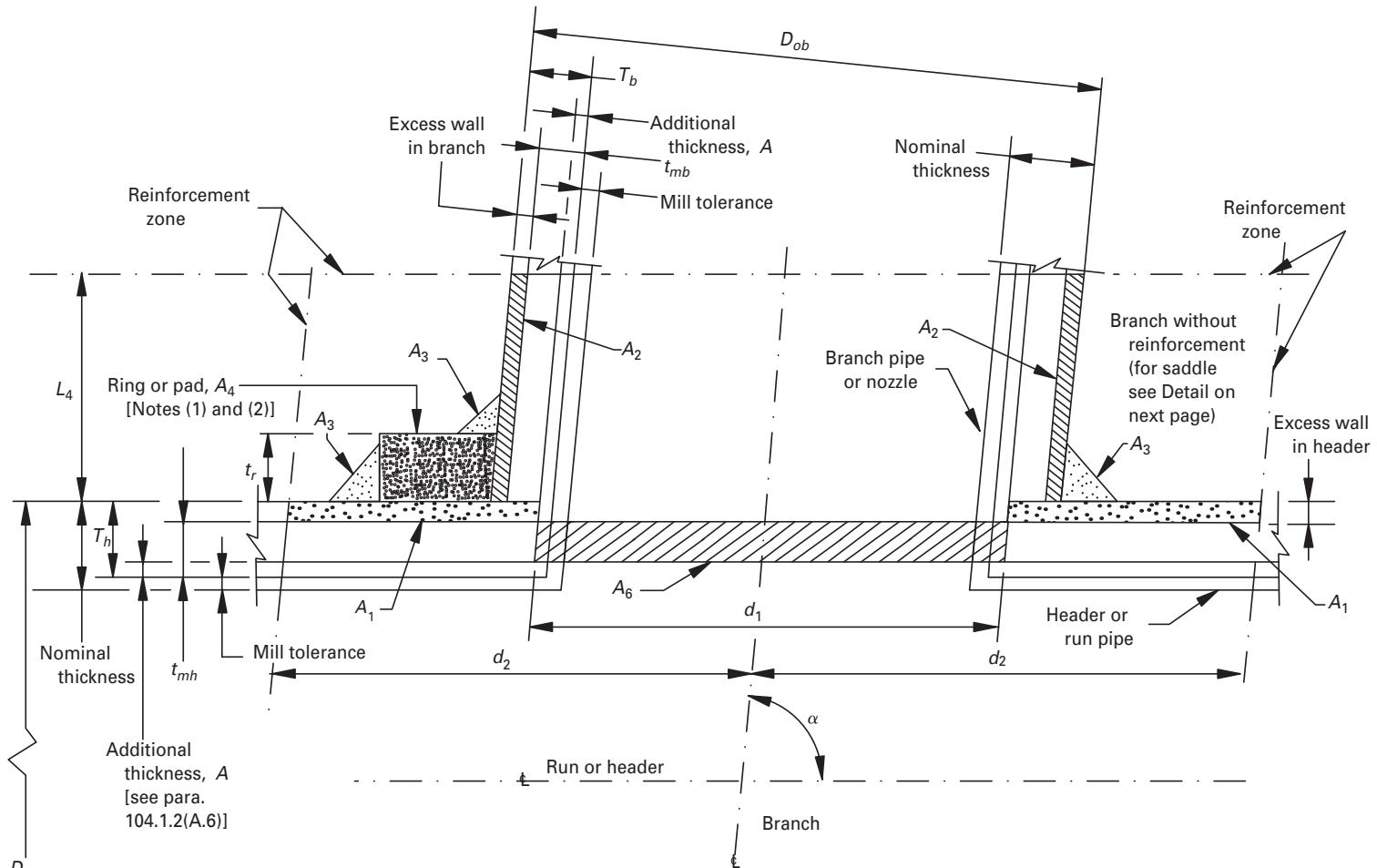

Example A

Explanation of areas:







- | | |
|--|--|
|  Area A ₁ — available reinforcement area (excess wall) in header |  Area A ₄ — metal in ring, pad, or integral reinforcement |
|  Area A ₂ — available reinforcement area (excess wall) in branch |  Area A ₅ — metal in saddle parallel to run (see Detail) |
|  Area A ₃ — available reinforcement area fillet weld metal |  Area A ₆ — pressure design area (expected at the end of service life) |

Fig. 104.3.1(D) Reinforcement of Branch Connections (Cont'd)



GENERAL NOTES:

- (a) This Figure illustrates the nomenclature of para. 104.3.1(D).
- (b) Required reinforcement area = $A_7 = A_6 (2 - \sin \alpha) = (t_{mh} - A)d_t (2 - \sin \alpha)$.
- (c) Available reinforcement areas = $A_1 + A_2 + A_3 + A_4 + A_5$ (as applicable).
- (d) Available reinforcement areas \geq required reinforcement area.

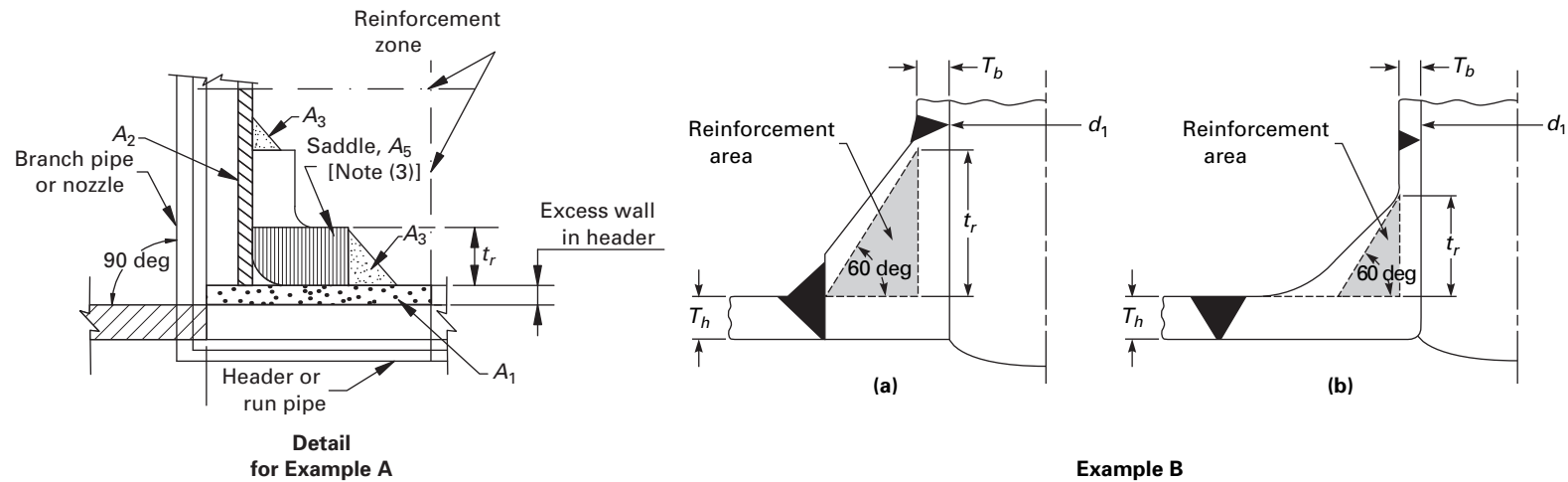
NOTES:

- (1) When a ring or pad is added as reinforcement (Example A), the value of reinforcement area may be taken in the same manner in which excess header metal is considered, provided the weld completely fuses the branch pipe, header pipe, and ring or pad. Typical acceptable methods of welding that meet the above requirement are shown in Fig. 127.4.8(D), sketches (c) and (d).
- (2) Width to height of rings and pads shall be reasonably proportioned, preferably on a ratio as close to 4:1 as the available horizontal space within the limits of the reinforcing zone along the run and the outside diameter of the branch will permit, but in no case may the ratio be less than 1:1.
- (3) Reinforcement saddles are limited to use on 90 deg branches (Example A Detail).

(D.2.5) *Reinforcement of Multiple Openings.* It is preferred that multiple branch openings be spaced so that their reinforcement zones do not overlap. If closer spacing is necessary, the following requirement shall be met. The two or more openings shall be reinforced in accordance with (D.2), with a combined reinforcement that has a strength equal to the combined strength of the reinforcement that would be required for the separate openings. No portion of the cross section shall be considered as applying to more than one opening, or be evaluated more than once in a combined area.

When more than two adjacent openings are to be provided with a combined reinforcement, the minimum distance between centers of any two of these openings should preferably be at least $1\frac{1}{2}$ times their average diameter, and the area of reinforcement between them shall be at least equal to 50% of the total required for these two openings.

(D.2.6) *Rings, Pads, and Saddles.* Reinforcement provided in the form of rings, pads, or saddles shall not be appreciably narrower at the side than at the crotch.

A vent hole shall be provided at the ring, pad, or saddle to provide venting during welding and heat treatment. Refer to para. 127.4.8(E).

Rings, pads, or saddles may be made in more than one piece, provided the joints between pieces have full thickness welds, and each piece is provided with a vent hole.

(D.2.7) *Other Designs.* The adequacy of designs to which the reinforcement requirements of para. 104.3 cannot be applied shall be proven by burst or proof tests on scale models or on full size structures, or by calculations previously substantiated by successful service of similar design.

(E) *Branch Connections Subject to External Pressure Requiring Reinforcement.* The reinforcement area in square inches (square millimeters) required for branch connections subject to external pressure shall be

$$0.5t_{mh}d_1(2 - \sin \alpha)$$

where t_{mh} is the required header wall thickness determined for straight pipe under external pressure, using procedures outlined in UG-28, UG-29, UG-30, and UG-31 of Section VIII, Division 1, of the ASME Boiler and Pressure Vessel Code.

Procedures established heretofore for connections subject to internal pressure shall apply for connections subject to external pressure provided that D_{ob} , D_{oh} , and t_r are reduced to compensate for external corrosion, if required by design conditions.

(F) *Branch Connections Subject to External Forces and Moments.* The requirements of the preceding paragraphs are intended to ensure safe performance of a branch connection subjected only to pressure. However, when external forces and moments are applied to a

branch connection by thermal expansion and contraction, by dead weight of piping, valves, and fittings, covering and contents, or by earth settlement, the branch connection shall be analyzed considering the stress intensification factors as specified in Mandatory Appendix D. Use of ribs, gussets, and clamps designed in accordance with para. 104.3.4 is permissible to stiffen the branch connection, but their areas cannot be counted as contributing to the required reinforcement area of the branch connection.

(G) *Extruded Outlets Integrally Reinforced*

(G.1) The following definitions, modifications, notations, and requirements are specifically applicable to extruded outlets. The designer shall make proper wall thickness allowances in order that the required minimum reinforcement is ensured over the design life of the system.

(G.2) *Definition.* An extruded outlet header is defined as a header in which the extruded lip at the outlet has an altitude above the surface of the run that is equal to or greater than the radius of curvature of the external contoured portion of the outlet; i.e., $h_o \geq r_o$. See nomenclature and Fig. 104.3.1(G).

(G.3) These rules apply only to cases where the axis of the outlet intersects and is perpendicular to the axis of the run. These rules do not apply to any nozzle in which additional nonintegral material is applied in the form of rings, pads, or saddles.

(G.4) The notation used herein is illustrated in Fig. 104.3.1(G). All dimensions are in inches (millimeters).

D_{ob} = outside diameter of branch pipe

D_{oh} = outside diameter of run

d_b = corroded internal diameter of branch pipe

d_c = corroded internal diameter of extruded outlet measured at the level of the outside surface of the run

d_r = corroded internal diameter of run

h_o = height of the extruded lip. This must be equal to or greater than r_o , except as shown in (G.4.2) below.

L_8 = altitude of reinforcement zone

$= 0.7\sqrt{D_{ob}T_o}$

$T_b - A$ = actual wall thickness (by measurement) or the minimum wall thickness permissible under the purchase specification of the branch pipe minus the corrosion allowance, in. (mm)

$T_h - A$ = actual wall thickness (by measurement) or the minimum wall thickness permissible under the purchase specification of the header pipe minus the corrosion allowance, in. (mm)

T_o = corroded finished thickness of extruded outlet measured at a height equal to r_o above the outside surface of the run

Fig. 104.3.1(G) Reinforced Extruded Outlets

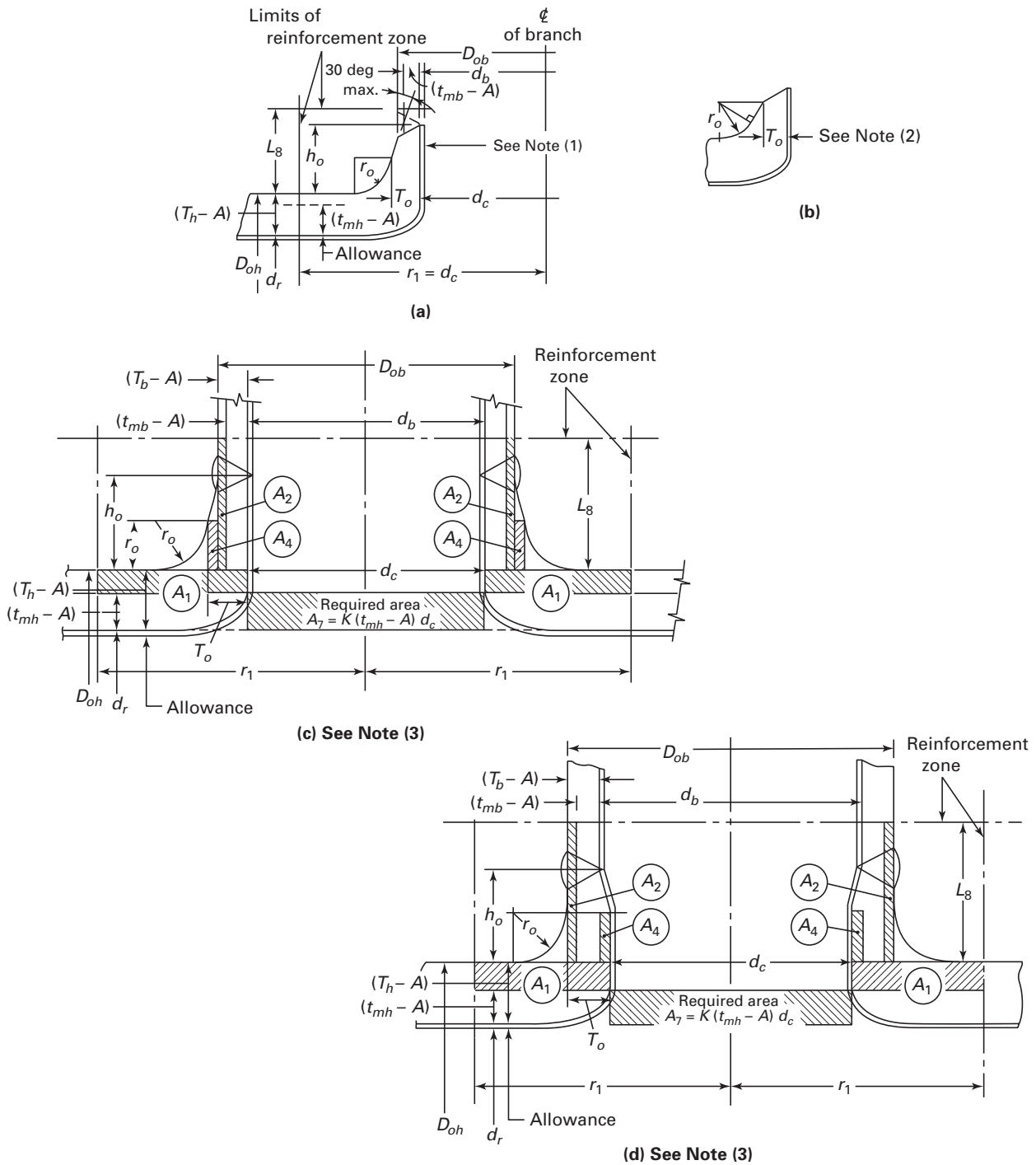

NOTES:

- (1) Taper bore inside diameter (if required) to match branch pipe 1:3 maximum taper.
- (2) Sketch to show method of establishing T_o when the taper encroaches on the crotch radius.
- (3) Sketch is drawn for condition where $k = 1.00$.

$t_{mb} - A$ = required thickness of branch pipe according to wall thickness eq. (7) or (8) in para. 104.1.2(A), but not including any thickness for corrosion

$t_{mh} - A$ = required thickness of the run according to eq. (7) or (8) in para. 104.1.2(A), but not including any allowance for corrosion

r_1 = half width of reinforcement zone (equal to d_c)

r_o = radius of curvature of external contoured portion of outlet measured in the plane containing the axes of the run and branch. This is subject to the following limitations:

(G.4.1) *Minimum Radius*. This dimension shall not be less than $0.05D_{ob}$ except that on branch diameters larger than NPS 30 (DN 750), it need not exceed 1.50 in. (38 mm).

(G.4.2) *Maximum Radius*. For outlet pipe sizes 6 in. (150 mm) nominal and larger, this dimension shall not exceed $0.10D_{ob} + 0.50$ in. ($0.10D_{ob} + 12.7$ mm). For outlet pipe sizes less than NPS 6 (DN 150), this dimension shall be not greater than 1.25 in. (32 mm).

(G.4.3) When the external contour contains more than one radius, the radius of any arc sector of approximately 45 deg shall meet the requirements of (G.4.1) and (G.4.2) above. When the external contour has a continuously varying radius, the radius of curvature at every point on the contour shall meet the requirements of (G.4.1) and (G.4.2) above.

(G.4.4) Machining other than grinding for weld cleanup shall not be employed in order to meet the above requirements.

(G.5) *Required Area*. The required area is defined as

$$A_7 = K (t_{mh} - A) d_c$$

where K shall be taken as follows:

For D_{ob}/D_{oh} greater than 0.60,

$$K = 1.00$$

For D_{ob}/D_{oh} greater than 0.15 and not exceeding 0.60,

$$K = 0.6 + \frac{2}{3} D_{ob}/D_{oh}$$

For D_{ob}/D_{oh} equal to or less than 0.15,

$$K = 0.70$$

The design must meet criteria that the reinforcement area defined in (G.6) below is not less than the required area.

(G.6) *Reinforcement Area*. The reinforcement area shall be the sum of areas

$$A_1 + A_2 + A_4$$

as defined below.

(G.6.1) Area A_1 is the area lying within the reinforcement zone resulting from any excess thickness available in the run wall.

$$A_1 = d_c(T_h - t_{mh})$$

(G.6.2) Area A_2 is the area lying within the reinforcement zone resulting from any excess thickness available in the branch pipe wall.

$$A_2 = 2L_8(T_b - t_{mb})$$

(G.6.3) Area A_4 is the area lying within the reinforcement zone resulting from excess thickness available in the extruded outlet lip.

$$A_4 = 2r_o [T_o - (T_b - A)]$$

(G.7) *Reinforcement of Multiple Openings*. It is preferred that multiple branch openings be spaced so that their reinforcement zones do not overlap. If closer spacing is necessary, the following requirements shall be met. The two or more openings shall be reinforced in accordance with (G) with a combined reinforcement that has a strength equal to the combined strength of the reinforcement that would be required for separate openings. No portion of the cross section shall be considered as applying to more than one opening, or be evaluated more than once in a combined area.

(G.8) In addition to the above, the manufacturer shall be responsible for establishing and marking on the section containing extruded outlets, the design pressure and temperature. The manufacturer's name or trademarks shall be marked on the section.

104.3.3 Miters. Miter joints, and the terminology related thereto, are described in Mandatory Appendix D. A widely spaced miter with

$$\theta < 9 \sqrt{\frac{t_n}{r}} \text{ deg}$$

shall be considered to be equivalent to a girth butt-welded joint, and the rules of this paragraph do not apply. Miter joints, and fabricated pipe bends consisting of segments of straight pipe welded together, with θ equal to or greater than this calculated value may be used within the limitations described below.

(A) Pressure shall be limited to 10 psi (70 kPa) under the following conditions:

(A.1) The assembly includes a miter weld with $\theta > 22.5$ deg, or contains a segment that has a dimension

$$B < 6t_n$$

(A.2) The thickness of each segment of the miter is not less than that determined in accordance with para. 104.1.

(A.3) The contained fluid is nonflammable, non-toxic, and incompressible, except for gaseous vents to atmosphere.

(A.4) The number of full pressure cycles is less than 7,000 during the expected lifetime of the piping system.

(A.5) Full penetration welds are used in joining miter segments.

(B) Pressure shall be limited to 100 psi (700 kPa) under the conditions defined in (A.2), (A.3), (A.4), and (A.5) above, in addition to the following:

(B.1) the angle θ does not exceed 22.5 deg

(B.2) the assembly does not contain any segment that has a dimension

$$B < 6t_n$$

(C) Miters to be used in other services or at design pressures above 100 psi (700 kPa) shall meet the requirements of para. 104.7.

(C.1) When justification under para. 104.7 is based on comparable service conditions, such conditions must be established as comparable with respect to cyclic as well as static loadings.

(C.2) When justification under para. 104.7 is based on an analysis, that analysis and substantiating tests shall consider the discontinuity stresses that exist at the juncture between segments; both for static (including brittle fracture) and cyclic internal pressure.

(C.3) The wall thickness, t_s , of a segment of a miter shall not be less than specified in (C.3.1) or (C.3.2) below, depending on the spacing.

(C.3.1) For closely spaced miter bends (see Mandatory Appendix D for definition)

$$t_s = t_m \frac{2 - r/R}{2(1 - r/R)}$$

(C.3.2) For widely spaced miters (see Mandatory Appendix D for definition)

$$t_s = t_m(1 + 0.64\sqrt{r/t_s} \tan \theta)$$

(The above equation requires an iterative or quadratic solution for t_s .)

104.3.4 Attachments. External and internal attachments to piping shall be designed so as not to cause flattening of the pipe, excessive localized bending stresses, or harmful thermal gradients in the pipe wall. It is important that such attachments be designed to minimize stress concentrations in applications where the number of stress cycles, due either to pressure or thermal effect, is relatively large for the expected life of the equipment.

104.4 Closures

104.4.1 General. Closures for power piping systems shall meet the applicable requirements of this Code and shall comply with the requirements described in (A) or (B) below. Closures may be made

(A) by use of closure fittings, such as threaded or welded plugs, caps, or blind flanges, manufactured in accordance with standards listed in Table 126.1, and used within the specified pressure-temperature ratings, or

(B) in accordance with the rules contained in the ASME Boiler and Pressure Vessel Code, Section I, Power Boilers, PG-31, or Section VIII, Pressure Vessels, Division 1, UG-34 and UW-13, calculated from

$$t_m = t + A$$

where

t = pressure design thickness, calculated for the given closure shape and direction of loading using appropriate equations and procedures in Section I or Section VIII, Division 1 of the ASME Boiler and Pressure Vessel Code

The definition of A and the symbols used in determining t shall have the definitions shown herein, instead of those given in the ASME Boiler and Pressure Vessel Code.

Attachment of a welded flat permanent closure with only a single fillet weld is not permitted.

104.4.2 Openings in Closures. Openings in closures may be made by welding, extruding, or threading. Attachment to the closure shall be in accordance with the limitations provided for such connections in para. 104.3.1 for branch connections. If the size of the opening is greater than one-half of the inside diameter of the closure, the opening shall be designed as a reducer in accordance with para. 104.6.

Other openings in closures shall be reinforced in accordance with the requirements of reinforcement for a branch connection. The total cross-sectional area required for reinforcement in any plane passing through the center of the opening and normal to the surface of the closure shall not be less than the quantity of d_5t , where

d_5 = diameter of the finished opening, in. (mm)

t = as defined in (B) above

104.5 Pressure Design of Flanges and Blanks

104.5.1 Flanges — General

(A) Flanges of sizes NPS 24 (DN 600) and smaller, that are manufactured in accordance with ASME B16.1 and B16.5, shall be considered suitable for use at the primary service ratings (allowable pressure at service temperature) except the slip-on flanges to ASME B16.5

(16)

shall be limited in application to no higher than Class 300 primary pressure service rating. Refer to para. 127.4.4.

For flanges larger than NPS 24 (DN 600), and manufactured in accordance with the Specifications and Standards listed in Table 126.1, the designer is cautioned about the dimensionally different designs that are available, as well as the limitations of their application.

Flanges not made in accordance with the Specifications and Standards listed in Table 126.1 shall be designed in accordance with Section VIII, Division 1 of the ASME Boiler and Pressure Vessel Code, except that the requirements for fabrication, assembly, inspection, and testing, and the pressure and temperature limits for materials of this Code for Pressure Piping shall govern. Certain notations used in the ASME Code, namely, P , S_a , S_b , and S_f , shall have the meanings described below instead of those given in the ASME Code. All other notations shall be as defined in the ASME Code.

P = design pressure, psi (kPa) (see paras. 101.2.2 and 101.2.4)

S_a = bolt design stress at atmospheric temperature, psi (kPa)

S_b = bolt design stress at design temperature, psi (kPa)

S_f = allowable stress for flange material or pipe, psi (kPa) (see para. 102.3.1 and Allowable Stress Tables) (stress values converted from MPa to kPa)

For certain specific applications, see the limitations of paras. 122.1.1(F), (G), and (H).

(B) These flange design rules are not applicable to flat face designs employing full face gaskets that extend beyond the bolts.

(C) The bolt design stress in (A) above shall be as established in Section VIII, Division 1 of the ASME Boiler and Pressure Vessel Code, Nonmandatory Appendix P for ferrous materials.

(D) Application of bolting materials for flanged joints is covered in para. 108.5.

104.5.2 Blind Flanges

(A) Blind flanges manufactured in accordance with the standards listed in Table 126.1 shall be considered suitable for use at the pressure–temperature rating specified by such standards.

(B) The required thickness of blind flanges not manufactured in accordance with standards in Table 126.1 shall be calculated from eq. (13).

$$t_m = t + A \quad (13)$$

where

t = pressure design thickness as calculated for the given style of blind flange from the appropriate equations for bolted flat cover plates in Section I of the ASME Boiler and Pressure Vessel Code. Certain notations used in these equations, namely, P and SE [see para. 104.1.2(A), footnote 3], shall be considered to have the meanings described in para. 104.1.2(A) instead of those given in the ASME Code. All other notations shall be as defined in the ASME Code.

104.5.3 Blanks

(A) The required thickness of permanent blanks (see Fig. 104.5.3) shall be calculated from the equation

$$t_m = t + A$$

where

t = pressure design thickness as calculated from eq. (14)

$$t = d_6 \sqrt{\frac{3P}{16SE}} \quad (14)$$

See para. 104.1.2(A), footnote 3.

d_6 = inside diameter of gasket for raised or flat (plain) face flanges, or the gasket pitch diameter for retained gasketed flanges, in. (mm)

(B) Blanks to be used for test purposes only shall have a minimum thickness not less than the pressure design thickness t specified above except that P shall be not less than the test pressure and SE [see para. 104.1.2(A), footnote 3] may be taken as the specified minimum yield strength of the blank material if the test fluid is incompressible.

(C) Attachment of a welded flat permanent blank with only a single fillet weld is not permitted.

104.6 Reducers

Flanged reducer fittings manufactured in accordance with the Standards listed in Table 126.1 shall be considered suitable for use at the specified pressure–temperature ratings. Where butt welding reducers are made to a nominal pipe thickness, the reducers shall be considered suitable for use with pipe of the same nominal thickness.

104.7 Other Pressure-Containing Components

104.7.1 Listed Components. Pressure-containing components manufactured in accordance with the standards listed in Table 126.1 shall be considered suitable for use under normal operating conditions at or below the specified pressure–temperature ratings. However, the user is cautioned that where certain standards or manufacturers may impose more restrictive allowances

Fig. 104.5.3 Types of Permanent Blanks

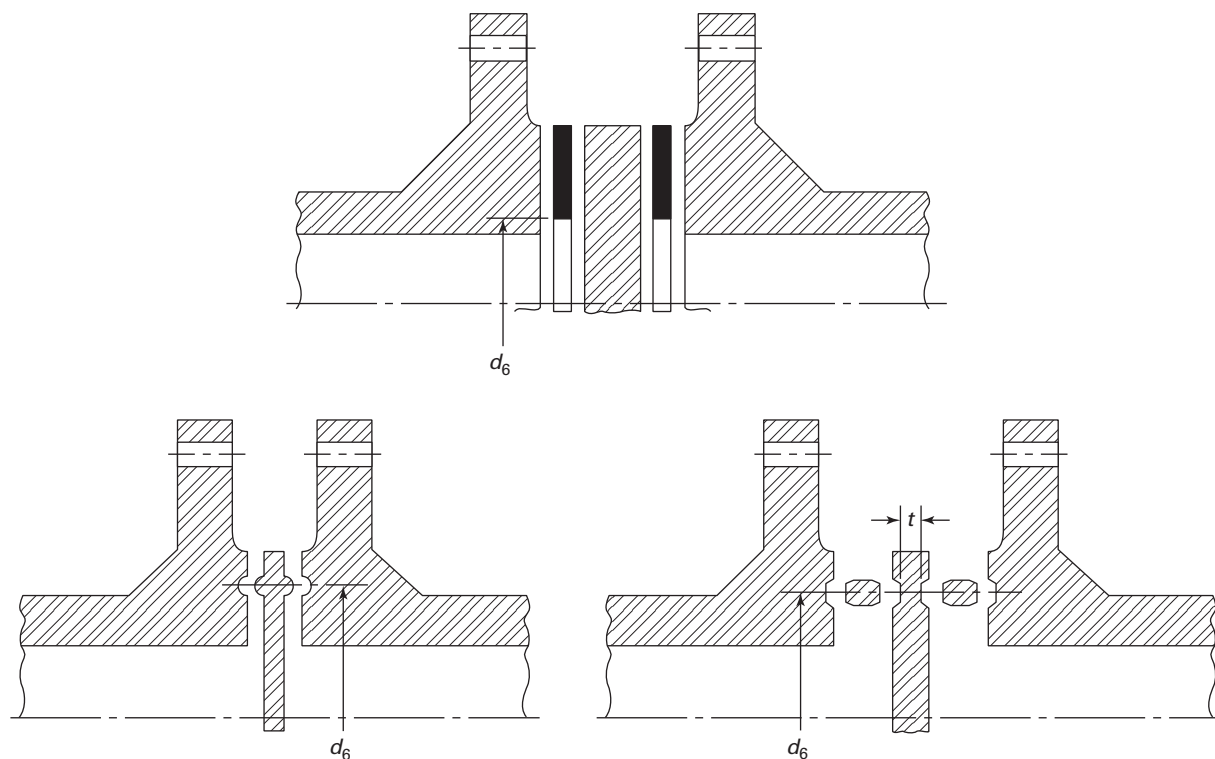

for variation from normal operation than those established by this Code, the more restrictive allowances shall apply.

104.7.2 Specially Designed Components. The pressure design of components not covered by the standards listed in Table 126.1 or for which design formulas and procedures are not given in this Code shall be based on calculations consistent with the design criteria of this Code. These calculations shall be substantiated by one or more of the means stated in (A), (B), (C), and (D) below.

(A) extensive, successful service experience under comparable conditions with similarly proportioned components of the same or similar material

(B) experimental stress analysis, such as described in the ASME Boiler and Pressure Vessel Code, Section VIII, Division 2, Annex 5-F

(C) proof test in accordance with either ASME B16.9; MSS SP-97; or the ASME Boiler and Pressure Vessel Code, Section I, A-22

(D) detailed stress analysis, such as finite element method, in accordance with the ASME Boiler and Pressure Vessel Code, Section VIII, Division 2, Part 5, except that the basic material allowable stress from the Allowable Stress Tables of Mandatory Appendix A shall be used in place of S_m

For any of (A) through (D) above, it is permissible to interpolate between sizes, wall thicknesses, and pressure

classes and to determine analogies among related materials.

Calculations and documentation showing compliance with this paragraph shall be available for the owner's approval, and, for boiler external piping, they shall be available for the Authorized Inspector's review.

104.8 Analysis of Piping Components (16)

To validate a design under the rules in this paragraph, the complete piping system must be analyzed for conditions and criteria dealing with the effects of thermal expansion, weight, other sustained loads, and applicable occasional loads such as those described in para. 101. Each component in the system must meet the limits in this paragraph. For pipe and fittings, the pressure term in eqs. (15) and (16) may be replaced with the alternative term for S_{lp} as defined in para. 102.3.2(A.3). The pressure term in eqs. (15) and (16) may not apply for bellows and expansion joints. When evaluating stresses in the vicinity of expansion joints, consideration must be given to actual cross-sectional areas that exist at the expansion joint.

104.8.1 Stress Due to Sustained Loads. The effects of pressure, weight, and other sustained mechanical loads shall meet the requirements of eq. (15). (16)

(U.S. Customary Units)

$$S_L = \frac{PD_o}{4t_n} + \frac{0.75iM_A}{Z} \leq 1.0 S_h \quad (15)$$

(SI Units)

$$S_L = \frac{PD_o}{(1\ 000)4t_n} + \frac{0.75iM_A}{Z} \leq 1.0 S_h$$

where

i = stress intensification factor (see Mandatory Appendix D). The product $0.75i$ shall never be taken as less than 1.0.

M_A = resultant moment loading on cross section due to weight and other sustained loads, in-lb (mm-N) (see para. 104.8.4)

S_h = basic material allowable stress at maximum (hot) temperature [see para. 102.3.2(B)]

S_L = sum of the longitudinal stresses due to pressure, weight, and other sustained loads

Z = section modulus, in.³ (mm³) (see para. 104.8.4)

104.8.2 Stress Due to Occasional Loads. The effects of pressure, weight, other sustained loads, and occasional loads including earthquake shall meet the requirements of eq. (16).

(U.S. Customary Units)

$$\frac{PD_o}{4t_n} + \frac{0.75iM_A}{Z} + \frac{0.75iM_B}{Z} \leq kS_h \quad (16)$$

(SI Units)

$$\frac{PD_o}{(1\ 000)4t_n} + \frac{0.75iM_A}{Z} + \frac{0.75iM_B}{Z} \leq kS_h$$

Terms same as para. 104.8.1, except

k = 1.15 for occasional loads acting for no more than 8 hr at any one time and no more than 800 hr/yr [see para. 102.3.3(A)]

= 1.2 for occasional loads acting for no more than 1 hr at any one time and no more than 80 hr/yr [see para. 102.3.3(A)]

M_B = resultant moment loading on the cross section due to occasional loads, such as thrusts from relief/safety valve loads, from pressure and flow transients, and earthquake, in.-lb (mm-N) [see paras. 102.3.3(A) and 104.8.4]

(16) 104.8.3 Stress Due to Displacement Load Ranges.

The effects of thermal expansion and other cyclic loads shall meet the requirements of eq. (17).

$$S_E = \frac{iM_C}{Z} \leq S_A \quad (17)$$

Terms same as para. 104.8.1, except

M_C = resultant moment loading range on the cross section due to the reference displacement load range. For flexibility analyses, the resultant moment due to the ambient to normal operating load range and eq. (1A) are typically used, in.-lb (mm-N) [see paras. 102.3.2(B), 104.8.4, and 119.7].

Fig. 104.8.4 Cross Section Resultant Moment Loading

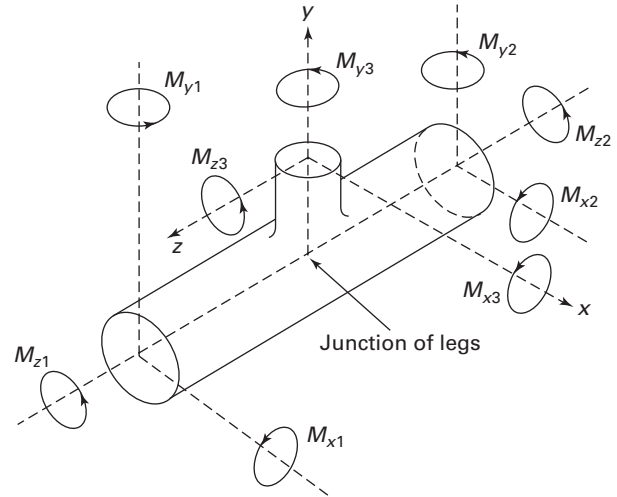

104.8.4 Moments and Section Modulus

(A) For eqs. (15), (16), and (17), the resultant moments for straight through components, curved pipe, or welding elbows may be calculated as follows:

$$M_j = (M_{xj}^2 + M_{yj}^2 + M_{zj}^2)^{1/2}$$

where

j = A, B, or C as defined in paras. 104.8.1, 104.8.2, and 104.8.3

Z = section modulus of piping, in.³ (mm³)

(B) For full outlet branch connections, calculate the resultant moment of each leg separately in accordance with (A) above. Use Z , section modulus, in eqs. (15), (16), and (17) as applicable to branch or run pipe. Moments are taken at the junction point of the legs. See Fig. 104.8.4.

(C) For reduced outlets, calculate the resultant moment of each leg separately in accordance with (A) above. Moments are to be taken at the junction point of the legs, unless the designer can demonstrate the validity of a less conservative method. See Fig. 104.8.4. For the reduced outlet branch, except for branch connections covered by Mandatory Appendix D, Fig. D-1,

$$M_C = \sqrt{M_{x3}^2 + M_{y3}^2 + M_{z3}^2}$$

and

$Z = \pi r_b^2 t_e$ (effective section modulus)

r_b = branch mean cross-sectional radius, in. (mm)

t_e = effective branch wall thickness, in. (mm)
= lesser of t_{nh} or it_{nb} in eq. (17), or lesser of t_{nh} or $0.75it_{nbr}$, where $0.75i \geq 1.0$, in eqs. (15) and (16)

For the reduced outlet branch connections covered by Fig. D-1,

$$M_A, M_B, \\ M_C = \sqrt{M_{x3}^2 + M_{y3}^2 + M_{z3}^2}$$

and

$$Z = \pi r'_m{}^2 T_b$$

If L_1 in Fig. D-1, illustrations (a), (b), and (c) equals or exceeds $0.5 \sqrt{r_i T_b}$, then r'_m can be taken as the radius to the center of T_b when calculating the section modulus and the stress intensification factor. For such a case, the transition between branch pipe and nozzle must be evaluated separately from the branch connection.

For the main run outlets,

$$M_A, M_B, \\ M_C = \sqrt{M_{x1}^2 + M_{y1}^2 + M_{z1}^2} \\ = \sqrt{M_{x2}^2 + M_{y2}^2 + M_{z2}^2}$$

and

$$Z = \text{section modulus of pipe, in.}^3 \text{ (mm}^3\text{)}$$

PART 3 SELECTION AND LIMITATIONS OF PIPING COMPONENTS

105 PIPE

105.1 General

Pipe conforming to the standards and specifications listed in Mandatory Appendix A shall be used within the range of temperatures for which allowable stresses are given within the limitations specified herein.

105.2 Metallic Pipe

105.2.1 Ferrous Pipe

(A) Furnace butt welded steel pipe shall not be used for flammable, combustible, or toxic fluids.

(B) Ductile iron pipe may be used for design pressures within the ratings established by the standards and specifications listed in Tables 126.1 and A-5 and Notes thereto, and the limitations herein and in para. 124.6. Ductile iron pipe shall not be used for flammable, combustible, or toxic fluids. Temperature limits for the use of ductile iron pipe are often determined by the type of elastomeric gasket used in the pipe joints, or the lining material used on the internal surface of the pipe. It is the responsibility of the Designer to determine whether these components are suitable for use in the particular application being considered. See para. 106.1(E).

105.2.2 Nonferrous Pipe

(A) Copper and brass pipe for water and steam service may be used for design pressures up to 250 psi (1 750 kPa) and for design temperatures to 406°F (208°C).

(B) Copper and brass pipe for air may be used in accordance with the allowable stresses given in the Allowable Stress Tables.

(C) Copper tubing may be used for dead-end instrument service with the limitations stated in para. 122.3.2(D).

(D) Copper, copper alloy, or aluminum alloy pipe or tube may be used under the conditions stated in para. 124.7. Copper, copper alloy, or aluminum pipe or tube shall not be used for flammable, combustible, or toxic fluids except as permitted in paras. 122.7 and 122.8.

105.3 Nonmetallic Pipe

(A) Rules and service limitations for plastic and elastomer-based piping materials, with or without fabric or fibrous material added for pressure reinforcement, are given in Mandatory Appendix N. These materials include thermoplastics and reinforced thermosetting resins.

(B) Metallic piping lined with nonmetals may be used for fluids that would corrode or be contaminated by unprotected metal. See para. 122.9 and Mandatory Appendix N.

(C) Reinforced concrete pipe may be used in accordance with the specifications listed in Table 126.1 for water service up to 150°F (65°C).

(D) A flexible nonmetallic pipe or tube assembly may be used in applications where

(D.1) satisfactory service experience exists

(D.2) the pressure and temperature conditions are within the manufacturer's recommendations

(D.3) the conditions described in paras. 104.7, 124.7, and 124.9 are met

106 FITTINGS, BENDS, AND INTERSECTIONS

106.1 Fittings

(A) Threaded, flanged, grooved and shouldered socket-welding, butt-welding, compression, push-on, mechanical gland, and solder-joint fittings made in accordance with the applicable standards in Table 126.1 may be used in power piping systems within the material, size, pressure, and temperature limitations of those standards, and within any further limitations specified in this Code. Material for fittings in flammable, combustible, or toxic fluid systems shall in addition conform to the requirements of paras. 122.7 and 122.8.

(B) Fittings not covered by the Standards listed in Table 126.1 may be used if they conform to para. 104.7.

(C) Cast butt-welding steel fittings not covered by the dimensional standards listed in Table 126.1 may be used up to the manufacturer's pressure and temperature ratings, provided they are radiographed in accordance with MSS SP-54. Fittings with discontinuities in excess of those permitted by MSS SP-54 shall be rejected. The

purchaser may allow the repair of a rejected fitting provided it is reexamined and accepted in accordance with the requirements of MSS SP-54.

(D) Fabricated ends for grooved and shouldered type joints are acceptable, provided they are attached by full penetration welds, double fillet welds, or by threading. Fabricated ends attached by single fillet welds are not acceptable.

(E) Elastomeric gasket bell end fittings complying with applicable standards listed in Table 126.1 may be used for water service. Temperature limits for gray and ductile iron fittings using ANSI/AWWA C111/A21.11 joints are 150°F (65°C) for push-on joints and 120°F (49°C) for mechanical joints, based on standard water service gasket and lining materials. Fittings of this type using alternative materials, as allowed by AWWA C111, may be used for nonflammable, nontoxic service to 212°F (100°C), where suitability for the fluid and operating conditions has been established by test or experience. Temperature limits for bell and spigot fittings in nonmetallic pipe shall be per para. 105.3.

106.2 Bends and Intersections

Bends and extruded branch connections may be used when designed in accordance with the provisions of paras. 104.2 and 104.3, respectively. Mitters may be used within the limitations of para. 104.3.3.

106.3 Pipe Couplings and Unions

(A) Cast iron and malleable iron pipe couplings shall be limited in application as referenced in paras. 124.4 and 124.5, respectively.

(B) Straight thread couplings shall not be used.

(C) Class 3000 steel pipe unions constructed in accordance with the MSS standard SP-83 may be used, provided the system design conditions are within the standard's listed pressure-temperature ratings.

106.4 Flexible Metal Hose Assembly

(A) Flexible metal hose assemblies may be used to provide flexibility in a piping system, to isolate or control vibration, or to compensate for misalignment. The design conditions shall be in accordance with para. 101 and within the limitations of the assembly as recommended by the manufacturer. The basis for their application shall include the following service conditions: thermal cycling, bend radius, cycle life, and the possibility of corrosion and erosion. Installation shall be limited to a single-plane bend, free from any torsion effects during service conditions and nonoperating periods. Type of end-connector components shall be consistent with the requirements of this Code.

(B) A flexible metal hose assembly, consisting of one continuous length of seamless or butt welded tube with helical or annular corrugations, is not limited as to application in piping systems that are within the scope of

this Code, provided that the conditions described in (A) above are met. For application subject to internal pressure the flexible element shall be contained within one or more separate layers of braided metal permanently attached at both coupling ends by welding or brazing. For application in toxic fluid systems, it is recommended that the designer also review the standards published by the relevant fluid industry for any additional safety and materials requirements that may be necessary.

(C) A flexible metal hose assembly consisting of wound interlocking metal strips may be applied to atmospheric vent systems only and shall not be used in systems that convey high temperature, flammable, toxic, or searching-type fluids. Where applicable, as determined by the designer and within the limitations described in para. 122.6 and those imposed by the manufacturer, this type of hose assembly may be used at pressure relieving devices.

107 VALVES

107.1 General

(A) Valves complying with the standards and specifications listed in Table 126.1 shall be used within the specified pressure-temperature ratings. Unless otherwise required in the individual standards and specifications listed in Table 126.1, such steel valves shall be pressure tested in accordance with MSS SP-61.

(B) Valves not complying with (A) above shall be of a design, or equal to the design, that the manufacturer recommends for the service as stipulated in para. 102.2.2. Such valves shall be pressure tested in accordance with MSS SP-61.

(C) Some valves are capable of sealing simultaneously against a pressure differential between an internal cavity of the valve and the adjacent pipe in both directions. Where liquid is entrapped in such a valve and is subsequently heated, a dangerous rise in pressure can result. Where this condition is possible, the owner shall provide means in design, installation, and/or operation to ensure that the pressure in the valve shall not exceed the rated pressure for the attained temperature. A relief device used solely for the overpressure protection from such entrapped fluid and conforming to (A) or (B) above need not comply with the requirements of para. 107.8. Any penetration of the pressure retaining wall of the valve shall meet the requirements of this Code.

(D) Only valves designed such that the valve stem is retained from blowout by an assembly that functions independently of the stem seal retainer shall be used.

(E) Materials used for pressure retention for valves in flammable, combustible, or toxic fluid systems shall in addition conform to the requirements of paras. 122.7 and 122.8.

(F) When selecting diaphragm valves in accordance with MSS standard SP-88, the designer shall specify the proper category pressure–temperature rating for the system design conditions, and should consider the expected in-service and shelf lives of the diaphragm material.

(G) Pressure regulating valves may have pressure ratings in accordance with ANSI/FCI Standard 79-1. Regulators having two static pressure ratings, i.e., inlet vs. outlet, shall be installed with adequate overpressure protection devices to prevent excessive downstream pressure resulting from any system failure. Refer to paras. 122.5 and 122.14.

107.2 Marking

Each valve shall bear the manufacturer's name or trademark and reference symbol to indicate the service conditions for which the manufacturer guarantees the valve. The marking shall be in accordance with ASME B16.5 and B16.34. MSS SP-25 may also be used for guidance.

107.3 Ends

Valves may be used with flanged, threaded, butt welding, socket welding, or other ends in accordance with applicable standards as specified in para. 107.1(A).

(16) 107.4 Stem Threads

Where threaded stem valves are used, stem threads may be internal or external with reference to the valve bonnet. Outside screw and yoke design shall be used for valves NPS 3 (DN 80) and larger for pressures above 600 psi (4 135 kPa). This requirement is not applicable to quarter-turn valves that comply with all other provisions of this Code.

107.5 Bonnet Joints

Bonnet joints may be of flanged, welded, pressure seal, union type, or other design, except that screwed bonnet connections in which the seal depends on a steam tight threaded joint shall not be permitted as source valves in steam service at pressures above 250 psi (1 750 kPa).

107.6 Bypasses

Sizes of bypasses shall be in accordance with MSS SP-45 as a minimum standard. Pipe for bypasses shall be at least schedule 80 seamless, and of a material of the same nominal chemical composition and physical properties as that used for the main line. Bypasses may be integral or attached.

107.8 Pressure-Relieving Valves and Devices

107.8.1 General. Pressure-relieving valves and devices shall conform to the requirements specified in this Code for flanges, valves, and fittings for the pressures and temperatures to which they may be subjected.

107.8.2 Pressure-Relieving Valves on Boiler External Piping. Safety, safety-relief, and power-actuated pressure-relieving valves on boiler external piping shall be in accordance with para. 122.1.7(D.1) of this Code.

107.8.3 Pressure Relief Requirements on Nonboiler External Piping

(A) Reheater safety valves on reheat piping shall conform to para. 122.1.7(D.1).

(B) Safety, safety-relief, relief, and pilot-operated pressure relief valves shall be in accordance with UG-126 of ASME Boiler and Pressure Vessel Code, Section VIII, Division 1.

(C) Nonreclosing pressure relief devices, such as rupture disks, pin devices/valves, and spring-loaded nonreclosing devices shall be in accordance with UG-127 of Section VIII, Division 1.

(D) Valves and devices in (B) and (C) above shall be constructed, manufactured, rated, and marked in accordance with the requirements of UG-128 through UG-132 and UG-136 through UG-138 of Section VIII, Division 1.

(E) An ASME Code Stamp and capacity certification are not required for valves with set pressures 15 psig [100 kPa (gage)] and lower.

107.8.4 Nonmandatory Appendix. For nonmandatory rules for the design of safety valve installations, see Nonmandatory Appendix II of this Code.

108 PIPE FLANGES, BLANKS, FLANGE FACINGS, GASKETS, AND BOLTING

108.1 Flanges

Flanges shall conform to the design requirements of para. 104.5.1 or to the standards listed in Table 126.1. They may be integral or shall be attached to pipe by threading, welding, brazing, or other means within the applicable standards specified in Table 126.1.

108.2 Blanks

Blanks shall conform to the design requirements of para. 104.5.3.

108.3 Flange Facings

Flange facings shall be in accordance with the applicable standards listed in Tables 112 and 126.1. When bolting Class 150 standard steel flanges to flat face cast iron flanges, the steel flange shall be furnished with a flat face. Steel flanges of Class 300 raised face standard may be bolted to Class 250 raised face cast iron.

108.4 Gaskets

Gaskets shall be made of materials that are not injuriously affected by the fluid or by temperature. They shall be in accordance with Table 112.

108.5 U.S. Customary Bolting

108.5.1 General

(A) Bolts, bolt studs, nuts, and washers shall comply with applicable standards and specifications listed in Tables 112 and 126.1. Bolts and bolt studs shall extend completely through the nuts.

(B) Washers, when used under nuts, shall be of forged or rolled material with steel washers being used under steel nuts and bronze washers under bronze nuts.

(C) Nuts shall be provided in accordance with the requirements of the specification for the bolts and bolt studs.

(D) Alloy steel bolt studs shall be either threaded full length or provided with reduced shanks of a diameter not less than that at the root of the threads. They shall have ASME heavy hexagonal nuts. Headed alloy bolts shall not be used with other than steel or stainless steel flanges.

(E) All alloy steel bolt studs and carbon steel bolts or bolt studs and accompanying nuts shall be threaded in accordance with ASME B1.1 Class 2A for external threads and Class 2B for internal threads. Threads shall be the coarse-thread series except that alloy steel bolting $1\frac{1}{8}$ in. and larger in diameter shall be the 8-pitch-thread series.

(F) Carbon steel headed bolts shall have square, hex, or heavy hex heads (ASME B18.2.1) and shall be used with hex or heavy hex nuts (ASME B18.2.2). For bolt sizes smaller than $\frac{3}{4}$ in., square or heavy hex heads and heavy hex nuts are recommended. For bolt sizes larger than $1\frac{1}{2}$ in., bolt studs with a hex or heavy hex nut on each end are recommended. For cast iron or bronze flanges using $\frac{3}{4}$ in. and larger carbon steel headed bolts, square nuts may be used.

108.5.2 For the various combinations of flange materials, the selection of bolting materials and related rules concerning flange faces and gaskets shall be in accordance with para. 108 and Table 112.

108.5.3 Bolting requirements for components not covered by para. 108.5.2 shall be in accordance with para. 102.2.2.

108.6 Metric Bolting

108.6.1 General. The use of metric bolts, bolt studs, nuts, and washers shall conform to the general requirements of para. 108.5, but the following are allowed:

(A) Threads shall be in accordance with ASME B1.13M, M profile, with tolerance Class 6g for external threads and Class 6H for internal threads.

(B) Threads shall be the coarse-thread series for size M68 and smaller, and 6 mm fine-pitch for M70 and larger sizes, except that alloy steel bolting M30 and larger shall be the 3 mm fine-pitch.

(C) Nuts shall be heavy hex in accordance with ASME B18.2.4.6M. Headed bolts shall be either hex or

heavy hex in accordance with ASME B18.2.3.5M and B18.2.3.6M, respectively. Heavy hex heads are recommended for headed bolt sizes M18 and smaller.

(D) Bolt studs are recommended in lieu of headed bolts for sizes M39 and larger.

108.6.2 Responsibilities When Specifying or Allowing Metric Bolting

(A) The piping designer is responsible for specifying the metric bolt size to be used with each class and size of flange.

(B) The designer shall ensure that the selected metric size will fit within the flange bolt holes, and that adequate space exists for bolt heads, nuts, and the assembly tool.

(C) In those instances where the selected metric bolt size is smaller in root thread area than the corresponding U.S. Customary size, the designer shall ensure that the selected size is capable of the required assembly torque and of producing the required gasket loading to adequately seal at design pressure. Further, the designer shall ensure sufficient contact area exists between the flange metal and both the nut and bolt head to withstand the required bolt loading. If not, larger bolting or a higher flange class shall be selected.

PART 4

SELECTION AND LIMITATIONS OF PIPING JOINTS

110 PIPING JOINTS

The type of piping joint used shall be suitable for the design conditions and shall be selected with consideration of joint tightness, mechanical strength, and the nature of the fluid handled.

111 WELDED JOINTS

111.1 General

Welded joints may be used in any materials allowed by this Code for which it is possible to qualify WPSs, welders, and welding operators in conformance with the rules established in Chapter V.

All welds shall be made in accordance with the applicable requirements of Chapter V.

111.2 Butt Welds

111.2.1 Design of Butt Welds. The design of butt welds shall include the evaluation of any expected joint misalignment [para. 127.3(C)] that may result from specification of joint geometries at variance with the recommendations of this Code.

111.2.2 Backing Rings for Butt Welds. If backing rings are used in services where their presence will result in severe corrosion or erosion, the backing ring shall be removed and the internal surface ground smooth. In

such services, where it is impractical to remove the backing ring, consideration shall be given to welding the joint without a backing ring, or with a consumable type insert ring.

111.3 Socket Welds

111.3.1 Restrictions on size of socket welded components are given in paras. 104.3.1(B.4), 122.1.1(H), and 122.8.2(C). Special consideration should be given to further restricting the use of socket welded piping joints where temperature or pressure cycling or severe vibration is expected to occur or where the service may accelerate crevice corrosion.

111.3.2 Dimensions for sockets of socket welding components shall conform to ASME B16.5 for flanges and ASME B16.11 for fittings. Assembly of socket welded joints shall be made in accordance with para. 127.3(E).

111.3.3 A branch connection socket welded directly into the wall of the run pipe shall be in accordance with requirements of para. 104.3.1(B.4).

111.3.4 Drains and bypasses may be attached to a fitting or valve by socket welding, provided the socket depth, bore diameter, and shoulder thickness conform to the requirements of ASME B16.11.

111.4 Fillet Welds

Fillet welds shall have dimensions not less than the minimum dimensions shown in Figs. 127.4.4(B), 127.4.4(C), and 127.4.8(D).

111.5 Seal Welds

Seal welding of connections, including threaded joints, may be used to avoid joint leakage, but the welding shall not be considered as contributing any strength to the joint. Also see para. 127.4.5. Seal welded threaded joints are subject to the limitations of para. 114.

112 FLANGED JOINTS

Flanged joints shall conform to paras. 108 and 110 and Table 112.

113 EXPANDED OR ROLLED JOINTS

Expanded or rolled joints may be used where experience or test has demonstrated that the joint is suitable for the design conditions and where adequate provisions are made to prevent separation of the joint.

114 THREADED JOINTS

Threaded joints may be used within the limitations specified in para. 106 and within the other limitations specified herein.

114.1

All threads on piping components shall be taper pipe threads in accordance with the applicable standards listed in Table 126.1. Threads other than taper pipe threads may be used for piping components where tightness of the joint depends on a seal weld or a seating surface other than the threads, and where experience or test has demonstrated that such threads are suitable.

114.2

114.2.1

(A) Threaded joints are prohibited where any of the following conditions is expected to occur:

(A.1) temperatures above 925°F (496°C), except as permitted by paras. 114.2.2 and 114.2.3

(A.2) severe erosion

(A.3) crevice corrosion

(A.4) shock

(A.5) vibration

(B) The maximum size limitations in Table 114.2.1 apply to threaded joints in the following services:

(B.1) steam and water at temperatures above 220°F (105°C)

(B.2) flammable gases, toxic gases or liquids, and nonflammable nontoxic gases [also subject to the exceptions identified in paras. 122.8(B) and 122.8.2(C.2)]

114.2.2 Threaded access holes with plugs, which serve as openings for radiographic inspection of welds, are not subject to the limitations of para. 114.2.1 and Table 114.2.1, provided their design and installation meets the requirement of para. 114.1. A representative type of access hole and plug is shown in PFI ES-16.

114.2.3 Threaded connections for insertion type instrument, control, and sampling devices are not subject to the temperature limitation stated in para. 114.2.1 nor the pressure limitations stated in Table 114.2.1 provided that design and installation meet the requirements of paras. 104.3.1 and 114.1. At temperatures greater than 925°F (495°C) or at pressures greater than 1,500 psi (10 350 kPa), these threaded connections shall be seal welded in accordance with para. 127.4.5. The design and installation of insertion type instrument, control, and sampling devices shall be adequate to withstand the effects of the fluid characteristics, fluid flow, and vibration.

114.3

Pipe with a wall thickness less than that of standard weight of ASME B36.10M steel pipe shall not be threaded, regardless of service. See para. 104.1.2(C.1) for additional threading limitations for pipe used in

(A) steam service over 250 psi (1 750 kPa)

(B) water service over 100 psi (700 kPa) and 220°F (105°C)

(16)

Table 112 Piping Flange Bolting, Facing, and Gasket Requirements
(Refer to Paras. 108, 110, and 112)

Item	Flange A Mating With Flange B		Bolting	Flange Facings	Gaskets
	Flange A	Flange B			
(a)	Class 25 cast iron	Class 25 cast iron	(a)(1) "Low strength" [Notes (1), (2), and (3)]	(a)(1) Flat	(a)(1) Flat ring nonmetallic to ASME B16.21, Table 1
			(a)(2) "Higher strength" or "low strength" [Notes (1) through (5)]	(a)(2) Flat	(a)(2) Full face nonmetallic to ASME B16.21, Table 1
(b)	Class 125 cast iron	Class 125 cast iron, Class 150 steel and stainless steel (excluding MSS SP-51), or Class 150 ductile iron	"Low strength" [Notes (1), (2), and (3)]	Flat	Flat ring; nonmetallic to ASME B16.21, Table 2
(c)	Class 125 cast iron, Class 150 bronze, MSS SP-51 stainless steel, or Nonmetallic	Class 125 cast iron, Class 150 bronze, Class 150 steel and stainless steel (including MSS SP-51), Class 150 ductile iron, or Nonmetallic	"Higher strength" or "low strength" [Notes (1) through (7)]	Flat	Full face nonmetallic to ASME B16.21, Table 2 [Notes (8), (9)]
(d)	Class 150 steel and stainless steel (excluding MSS SP-51), or Class 150 ductile iron	Class 150 steel and stainless steel (excluding MSS SP-51), or Class 150 ductile iron	(d)(1) "Low strength" [Notes (1), (2), and (3)]	(d)(1) Raised or flat on one or both flanges	(d)(1) Flat ring nonmetallic to ASME B16.5, Annex C, Group Ia, Table C1 [Note (10)]
			(d)(2) "Higher strength" [Notes (3), (4), and (5)]	(d)(2) Raised or flat on one or both flanges	(d)(2) Ring style to ASME B16.5, Annex C, Groups Ia and Ib, Table C1 [Notes (10) and (11)]
			(d)(3) "Higher strength" or "low strength" [Notes (1) through (5)]	(d)(3) Flat	(d)(3) Full face nonmetallic to ASME B16.5, Annex C, Group Ia material
(e)	Class 150 steel and stainless steel (excluding MSS SP-51)	Class 150 steel and stainless steel (excluding MSS SP-51)	"Higher strength" [Notes (3), (4), and (5)]	Ring joint	Ring joint to ASME B16.20

Table 112 Piping Flange Bolting, Facing, and Gasket Requirements (Cont'd)
(Refer to Paras. 108, 110, and 112)

Flange A Mating With Flange B					
Item	Flange A	Flange B	Bolting	Flange Facings	Gaskets
(f)	Class 250 cast iron	Class 250 cast iron, Class 300 steel and stainless steel, or Class 300 ductile iron	(f)(1) "Low strength" [Notes (1), (2), and (3)]	(f)(1) Raised or flat on one or both flanges	(f)(1) Flat ring nonmetallic to ASME B16.21, Table 3
			(f)(2) "Higher strength" or "low strength" [Notes (1) through (5)]	(f)(2) Flat	(f)(2) Full face nonmetallic to ASME B16.21, Table 6 (Class 300)
(g)	Class 300 bronze	Class 250 cast iron, Class 300 bronze, Class 300 steel and stainless steel, or Class 300 ductile iron	"Higher strength" or "low strength" [Notes (1) through (7)]	Flat	Full face nonmetallic to ASME B16.21, Table 11 [Note (8)]
(h)	Class 300 ductile iron	Class 300 steel and stainless steel, or Class 300 ductile iron	(h)(1) "Low strength" [Notes (1), (2), and (3)]	(h)(1) Raised or flat on one or both flanges	(h)(1) Flat ring nonmetallic to ASME B16.5, Annex C, Group Ia, Table C1 [Note (10)]
			(h)(2) "Higher strength" [Notes (3), (4) and (5)]	(h)(2) Raised or flat on one or both flanges	(h)(2) Ring style to ASME B16.5, Annex C [Notes (10) and (11)]
			(h)(3) "Higher strength" or "low strength" [Notes (1) through (5)]	(h)(3) Flat	(h)(3) Full face nonmetallic to ASME B16.5, Annex C, Group Ia material [Note (10)]

Table 112 Piping Flange Bolting, Facing, and Gasket Requirements (Cont'd)
(Refer to Paras. 108, 110, and 112)

Item	Flange A Mating With Flange B		Bolting	Flange Facings	Gaskets
	Flange A	Flange B			
(i)	Class 300 and higher classes, steel and stainless steel	Class 300 and higher classes, steel and stainless steel	(i)(1) “Low strength” [Notes (1), (2), and (3)]	(i)(1) Raised or flat on one or both flanges; large or small male and female; large or small tongue and groove	(i)(1) Flat ring nonmetallic to ASME B16.5, para. 6.11 and Annex C, Group Ia material [Note (10)]
			(i)(2) “Higher strength” [Notes (3), (4), and (5)]	(i)(2) Raised or flat on one or both flanges; large or small male and female; large or small tongue and groove	(i)(2) Ring style to ASME B16.5, para. 6.11 and Annex C [Notes (10) and (11)]
			(i)(3) “Higher strength” [Notes (3), (4), and (5)]	(i)(3) Ring joint	(i)(3) Ring joint to ASME B16.20
(j)	Class 800 cast iron	Class 800 cast iron	“Low strength” [Notes (1), (2), and (3)]	Raised or large male and female	Flat ring nonmetallic to ASME B16.21, Table 4

GENERAL NOTES:

- (a) Bolting (including nuts), flange facing, and gasket selection (materials, dimensions, bolt stress, gasket factor, seating stress, etc.) shall be suitable for the flanges, service conditions, and hydrostatic tests. There shall be no overstressing of the gasket or flanges from the expected bolt loading or external bending loads.
- (b) Unless otherwise stated, the flange facing described applies to both flanges A and B.
- (c) For flanges other than to ASME B16.1, in sizes larger than NPS 24 (DN 600) [NPS 12 (DN 300) in Class 2500], gasket dimensions should be verified against the flanges specified (e.g., MSS SP-44 and API 605).
- (d) The effective seating of a full face gasket shall extend to the outside edge of the flange. For flat or raised face flanges, a flat ring or ring style gasket shall be self-centering, extending to the inner edge of the bolt holes or bolts. Where the joint contains a cast iron, bronze, nonmetallic, or MSS SP-51 stainless steel flange, the effective gasket seating shall extend to the outside diameter of the gasket.
- (e) Unconfined nonmetallic gaskets shall not be used on flat or raised face flanges if the expected normal operating pressure exceeds 720 psi (4 950 kPa) or the temperature exceeds 750°F (400°C). Metal gaskets, spiral wound gaskets of metal with nonmetallic filler, and confined nonmetallic gaskets are not limited as to pressure or temperature provided the gasket materials are suitable for the maximum fluid temperatures.

Table 112 Piping Flange Bolting, Facing, and Gasket Requirements (Cont'd)
(Refer to Paras. 108, 110, and 112)

NOTES:

(1) "Low strength" bolting shall conform to ASTM:

A193, Grade B8A, B8CA, B8MA, or B8TA A193, Class 1, Grade B8, B8C, B8M, or B8T	A307, Grade B [bolting to A307, Grade B shall not be used at temperatures greater than 400°F (200°C)] A320, Class 1, Grade B8, B8C, B8M, or B8T
---	--

(2) Nuts for "low strength" bolting shall conform to the grade of ASTM A194 or A563 as required by the bolting specification.

(3) For temperatures below -20°F (-29°C), bolting conforming to the ASTM A320 classes and grades listed, respectively, in Note (4) "higher strength" and Note (1) "low strength" shall be used. For this bolting to ASTM A320, Grades L7, L7A, L7B, L7C, and L43, the nuts shall conform to ASTM A194, Grade 4 or 7 with impact requirements of A320. For bolting to the other grades of A320, the nuts shall conform to A320.

(4) "Higher strength" bolting shall conform to ASTM:

A193, Grade B5, B6, B6X, B7, B7M, or B16 A193, Class 2, Grade B8, B8C, B8M, or B8T	A354, Grade BC or BD A437, Grade B4B, B4C, or B4D
A320, Grade L7, L7A, L7B, L7C, or L43 A320, Class 2, Grade B8, B8C, B8F, B8M, or B8T	A453, Grade 651 or 660

(5) Nuts for "higher strength" bolting shall conform to the grade of ASTM A194, A437, A453, A563, or A564, as required by the bolting specification.

(6) Additionally, for joints containing bronze flanges, nonferrous bolting conforming to the following may be used:

ASTM B98, UNS C65100, C65500, and C66100; half hard; to 350°F (177°C) maximum ASTM B150, UNS C61400, to 500°F (260°C) maximum ASTM B150, UNS C63000 and C64200, to 550°F (288°C) maximum	ASTM B164, UNS N04400 and N04405; hot finish; 550°F (288°C) maximum ASTM B164, UNS N04400, cold drawn, cold drawn and stress relieved, or cold drawn and stress equalized; and N04405, cold drawn, to 500°F (260°C) maximum
--	--

(7) Where a flanged joint contains dissimilar materials (e.g., bronze flanges with steel bolting) and has a design temperature exceeding 300°F (149°C), the differences in coefficients of expansion shall be considered.

(8) For bronze flanges where "low strength" or nonferrous bolting is used, nonmetallic gaskets having seating stresses greater than 1,600 psi shall not be used.

(9) For stainless steel flanges to MSS SP-51 and for nonmetallic flanges, preference shall be given to gasket materials having the lower minimum design seating stress as listed in ASME B16.5, Table C1, Group Ia.

(10) Where asbestos sheet, fiber, or filler material for gaskets is specified in ASME B16.5, this limitation shall not apply to ASME B31.1 applications. Any nonmetallic material suitable for the operating conditions may be used in lieu of asbestos provided the requirements of Table 112 are met.

(11) For items (d)(2), (h)(2), and (i)(2), where two flat face flanges are used in a joint and the gasket seating width (considering both the gasket and the flanges) is greater than that of an ASME B16.5 flange having a standard raised face, the gasket material shall conform to ASME B16.5, Annex C, Group Ia.

Table 114.2.1 Threaded Joints Limitations

Maximum Size		Maximum Pressure	
NPS	DN	psi	MPa
3	80	400	3
2½	65	500	3.5
2	50	600	4
1½	40	900	6
1¼	32	1,000	7
1	25	1,200	8
≤¾	≤20	1,500	10

GENERAL NOTE: For instrument, control, and sampling lines, refer to para. 122.3.6(A.5).

115 FLARED, FLARELESS, AND COMPRESSION JOINTS, AND UNIONS

Flared, flareless, and compression type tubing fittings, and cast copper alloy fittings for flared copper tubes, may be used for tube sizes not exceeding 2 in. (50 mm) and unions may be used for pipe sizes not exceeding NPS 3 (DN 80) within the limitations of applicable standards and specifications listed in Table 126.1. Pipe unions shall comply with the limitations of para. 114.2.1.

In the absence of standards, specifications, or allowable stress values for the material used to manufacture the fitting, the designer shall determine that the type and the material of the fitting selected is adequate and safe for the design conditions in accordance with the following requirements:

(A) The pressure design shall meet the requirements of para. 104.7.

(B) A suitable quantity of the type, size, and material of the fittings to be used shall meet successful performance tests to determine the safety of the joint under simulated service conditions. When vibration, fatigue, cyclic conditions, low temperature, thermal expansion, or hydraulic shock are expected, the applicable conditions shall be incorporated in the test.

115.1 Compatibility

Fittings and their joints shall be compatible with the tubing or pipe with which they are to be used and shall conform to the range of wall thicknesses and method of assembly recommended by the manufacturer.

115.2 Pressure–Temperature Ratings

Fittings shall be used at pressure–temperature ratings not exceeding the recommendations of the manufacturer. Unions shall comply with the applicable standards listed within Table 126.1 and shall be used within the specified pressure–temperature ratings. Service conditions, such as vibration and thermal cycling, shall be considered in the application.

115.3 Threads

See para. 114.1 for requirements of threads on piping components.

115.4 Fitting and Gripping

Flareless fittings shall be of a design in which the gripping member or sleeve shall grip or bite into the outer surface of the tube with sufficient strength to hold the tube against pressure, but without appreciably distorting the inside tube diameter. The gripping member shall also form a pressure seal against the fitting body.

When using bite type fittings, a spot check shall be made for adequate depth of bite and condition of tubing by disassembling and reassembling selected joints.

Grip-type fittings that are tightened in accordance with manufacturer's instructions need not be disassembled for checking.

116 BELL END JOINTS

116.1 Elastomeric-Gasket Joints

Elastomeric-gasket bell end joints may be used for water and other nonflammable, nontoxic service where experience or tests have demonstrated that the joint is safe for the operating conditions and the fluid being transported. Provisions shall be made to prevent disengagement of the joints at bends and dead ends, and to support lateral reactions produced by branch connections or other causes.

116.2 Caulked Joints

Caulked joints, if used, shall be restricted to cold water service, shall not use lead as the caulking material in potable water service, and shall be qualified as specially designed components in accordance with para. 104.7.2. Provisions shall be made to prevent disengagement of the joints at bends and dead ends, and to support lateral reactions produced by branch connections or other causes.

117 BRAZED AND SOLDERED JOINTS

117.1 Brazed Joints

Brazed socket-type joints shall be made with suitable brazing alloys. The minimum socket depth shall be sufficient for the intended service. Brazing alloy shall either be end-fed into the socket or shall be provided in the form of a preinserted ring in a groove in the socket. The brazing alloy shall be sufficient to fill completely the annular clearance between the socket and the pipe or tube. The limitations of paras. 117.3(A) and (D) shall apply.

117.2 Soldered Joints

Soft soldered socket-type joints made in accordance with applicable standards listed in Table 126.1 may be

used within their specified pressure–temperature ratings. The limitations in paras. 117.3 and 122.3.2(E.2.3) for instrument piping shall apply. The allowances of para. 102.2.4 do not apply.

117.3 Limitations

(A) Brazed socket-type joints shall not be used on systems containing flammable or toxic fluids in areas where fire hazards are involved.

(B) Soldered socket-type joints shall be limited to systems containing nonflammable and nontoxic fluids.

(C) Soldered socket-type joints shall not be used in piping subject to shock or vibration.

(D) Brazed or soldered joints depending solely upon a fillet, rather than primarily upon brazing or soldering material between the pipe and sockets, are not acceptable.

118 SLEEVE COUPLED AND OTHER PROPRIETARY JOINTS

Coupling type, mechanical gland type, and other proprietary joints may be used where experience or tests have demonstrated that the joint is safe for the operating conditions, and where adequate provision is made to prevent separation of the joint.

PART 5 EXPANSION, FLEXIBILITY, AND PIPE-SUPPORTING ELEMENT

119 EXPANSION AND FLEXIBILITY

119.1 General

In addition to the design requirements for pressure, weight, and other sustained or occasional loadings (see paras. 104.1 through 104.7, 104.8.1, and 104.8.2), power piping systems subject to thermal expansion, contraction, or other displacement stress producing loads shall be designed in accordance with the flexibility and displacement stress requirements specified herein.

119.2 Displacement Stress Range

Piping system stresses caused by thermal expansion and piping displacements, referred to as displacement stresses, when of sufficient initial magnitude during system startup or extreme displacements, relax in the maximum stress condition as the result of local yielding or creep. A stress reduction takes place and usually appears as a stress of reversed sign when the piping system returns to the cold condition for thermal loads or the neutral position for extreme displacement loads. This phenomenon is designated as self-springing (or shake-down) of the piping and is similar in effect to cold springing. The extent of self-springing depends upon the material, the magnitude of the displacement stresses, the fabrication stresses, the hot service temperature, and

the elapsed time. While the displacement stresses in the hot or displaced condition tend to diminish with time and yielding, the sum of the displacement strains for the maximum and minimum stress conditions during any one cycle remains substantially constant. This sum is referred to as the strain range. However, to simplify the evaluation process, the strain range is converted to a stress range to permit the more usual association with an allowable stress range. The allowable stress range shall be as determined in accordance with para. 102.3.2(B).

119.3 Local Overstrain

Most of the commonly used methods of piping flexibility and cyclic stress analysis assume elastic or partly elastic behavior of the entire piping system. This assumption is sufficiently accurate for systems where plastic straining occurs at many points or over relatively wide regions, but fails to reflect the actual strain distribution in unbalanced systems where only a small portion of the piping undergoes plastic strain, or where, in piping operating in the creep range, the strain distribution is very uneven. In these cases, the weaker or higher stressed portions will be subjected to strain concentrations due to elastic follow-up of the stiffer or lower stressed portions. Unbalance can be produced

(A) by use of small pipe runs in series with larger or stiffer pipe, with the small lines relatively highly stressed

(B) by local reduction in size or cross section, or local use of a weaker material

(C) in a system of uniform size, by use of a line configuration for which the neutral axis or thrust line is situated close to the major portion of the line itself, with only a very small offset portion of the line absorbing most of the expansion strain

Conditions of this type should preferably be avoided, particularly where materials of relatively low ductility are used.

119.5 Flexibility

Power piping systems shall be designed to have sufficient flexibility to prevent piping displacements from causing failure from overstress of the piping components, overloading of anchors and other supports, leakage at joints, or detrimental distortion of connected equipment. Flexibility shall be provided by changes in direction in the piping through the use of fittings, bends, loops, and offsets. When piping bends, loops, and offsets are not able to provide adequate flexibility, provisions may be made to absorb piping displacements by utilizing expansion, swivel, or ball joints, or flexible metal hose assemblies.

119.5.1 Expansion, Swivel, or Ball Joints, and Flexible Metal Hose Assemblies. Except as stated in para. 101.7.2, these components may be used where experience or tests have demonstrated that they are suitable

for expected conditions of pressure, temperature, service, and cyclic life.

Restraints and supports shall be provided, as required, to limit movements to those directions and magnitudes permitted for the specific joint or hose assembly selected.

119.6 Piping Properties

The coefficient of thermal expansion and moduli of elasticity shall be determined from Mandatory Appendices B and C, which cover more commonly used piping materials. For materials not included in those Appendices, reference shall be to authoritative source data such as publications of the National Institute of Standards and Technology.

119.6.1 Coefficient of Thermal Expansion. The coefficient of thermal expansion shall be determined from values given in Mandatory Appendix B. The coefficient used shall be based on the highest average operating metal temperature and the lowest ambient metal temperature, unless other temperatures are justified. Mandatory Appendix B values are based on the assumption that the lowest ambient metal temperature is 70°F (20°C). If the lowest metal temperature of a thermal range to be evaluated is not 70°F (20°C), adjustment of the values in Mandatory Appendix B may be required.

119.6.2 Moduli of Elasticity. The cold and hot moduli of elasticity, E_c and E_h , shall be as shown in Mandatory Appendix C, Table C-1 for ferrous materials and Table C-2 for nonferrous materials, based on the temperatures established in para. 119.6.1.

119.6.3 Poisson's Ratio. Poisson's ratio, when required for flexibility calculations, shall be taken as 0.3 at all temperatures for all materials.

119.6.4 Stresses. Calculations for the stresses shall be based on the least cross section area of the component, using nominal dimensions at the location under consideration. Calculation for the reference displacement stress range, S_E , shall be based on the modulus of elasticity, E_c , at room temperature, unless otherwise justified.

119.7 Flexibility Analysis

119.7.1 Method of Analysis. All piping shall meet the following requirements with respect to flexibility:

(A) It shall be the designer's responsibility to perform an analysis unless the system meets one of the following criteria:

(A.1) The piping system duplicates a successfully operating installation or replaces a system with a satisfactory service record.

(A.2) The piping system can be adjudged adequate by comparison with previously analyzed systems.

(A.3) The piping system is of uniform size, has not more than two anchors and no intermediate restraints, is designed for essentially noncyclic service (less than

7,000 total cycles), and satisfies the following approximate criterion:

U.S. Customary Units

$$\frac{DY}{(L - U)^2} \leq 30 \frac{S_A}{E_c}$$

SI Units

$$\frac{DY}{(L - U)^2} \leq 208\,000 \frac{S_A}{E_c}$$

where

D = nominal pipe size (NPS), in. (mm)

E_c = modulus of elasticity at room temperature, psi (kPa)

L = developed length of pipe (total length of pipe taken along the piping longitudinal axes), ft (m)

S_A = allowable displacement stress range determined in accordance with para. 102.3.2(B), eq. (1A), psi (kPa)

U = anchor distance (length of straight line between the anchors), ft (m)

Y = resultant displacement between the anchors to be absorbed by the piping system, in. (mm)

WARNING: No general proof can be offered that this equation will yield accurate or consistently conservative results. It was developed for ferrous materials and is not applicable to systems used under severe cyclic conditions. It should be used with caution in configurations such as unequal leg U-bends, or near straight "saw-tooth" runs, or for large diameter thin-wall pipe, or where extraneous displacements (not in the direction connecting anchor points) constitute a large part of the total displacement, or where piping operates in the creep range. There is no assurance that anchor reactions will be acceptably low, even when a piping system meets the above requirements.

(B) All systems not meeting the above criteria, or where reasonable doubt exists as to adequate flexibility between the anchors, shall be analyzed by simplified, approximate, or comprehensive methods of analysis that are appropriate for the specific case. The results of such analysis shall be evaluated using para. 104.8.3, eq. (17).

(C) Approximate or simplified methods may be applied only if they are used for the range of configurations for which their adequate accuracy has been demonstrated.

(D) Acceptable comprehensive methods of analysis include: analytical, model tests, and chart methods that provide an evaluation of the forces, moments, and stresses caused by bending and torsion from the simultaneous consideration of terminal and intermediate restraints to thermal expansion of the entire piping system under consideration, and including all external movements transmitted to the piping by its terminal and intermediate attachments. Correction factors shall be applied for the stress intensification of curved pipe

and branch connections, as provided by the details of these rules, and may be applied for the increased flexibility of such component parts.

(16) **119.7.3 Basic Assumptions and Requirements.** In calculating the flexibility or displacement stresses of a piping system between anchor points, the system between anchor points shall be treated as a whole. The significance of all parts of the line and of all restraints, such as supports or guides, including intermediate restraints introduced for reducing moments and forces on equipment or small branch lines, shall be considered.

Flexibility calculations shall take into account stress-intensifying conditions found in components and joints. Credit may be taken when extra flexibility exists in such components. In the absence of more directly applicable data, the flexibility factors and stress-intensification factors shown in Mandatory Appendix D may be used.⁴ Alternatively, B31J may be used to determine stress-intensification factors.

Dimensional properties of pipe and fittings used in flexibility calculations shall be based on nominal dimensions.

The total reference displacement range resulting from using the coefficient of thermal expansion determined in accordance with para. 119.6.1 shall be used, whether or not the piping is cold sprung. Not only the expansion of the line itself, but also linear and angular movements of the equipment to which it is attached, shall be considered.

Where simplifying assumptions are used in calculations or model tests, the likelihood of attendant underestimates of forces, moments, and stresses, including the effects of stress intensification, shall be evaluated.

119.8 Movements

Movements caused by thermal expansion and loadings shall be determined for consideration of obstructions and design of proper supports.

119.9 Cold Spring

The beneficial effect of judicious cold springing in assisting a system to attain its most favorable position sooner is recognized. Inasmuch as the life of a system under cyclic conditions depends on the stress range rather than the stress level at any one time, no credit for cold spring is allowed with regard to stresses. In calculating end thrusts and moments acting on equipment, the actual reactions at any one time, rather than

their range, are significant. Credit for cold springing is accordingly allowed in the calculation of thrusts and moments, provided an effective method of obtaining the designed cold spring is specified and used.

119.10 Reactions

119.10.1 Computing Hot and Cold Reactions. In a piping system with no cold spring or an equal percentage of cold springing in all directions, the reactions (forces and moments) of R_h and R_c , in the hot and cold conditions, respectively, shall be obtained from the reaction, R , derived from the flexibility calculations based on the modulus of elasticity at room temperature, E_c , using eqs. (18) and (19). (16)

$$R_h = \left(1 - \frac{2}{3}C\right) \left(\frac{E_h}{E_c}\right) R \quad (18)$$

$$R_c = -CR, \text{ or}$$

$$= - \left[1 - \frac{(S_h)}{(S_E)} \cdot \frac{(E_c)}{(E_h)}\right] R \quad (19)$$

whichever is greater, and with the further condition that

$$\frac{(S_h)}{(S_E)} \cdot \frac{(E_c)}{(E_h)} < 1$$

where

C = cold spring factor varying from zero for no cold spring to 1.00 for 100% cold spring

E_c = modulus of elasticity in the cold condition, psi (MPa)

E_h = modulus of elasticity in the hot condition, psi (MPa)

R = maximum reaction for full expansion range based on E_c , which assumes the most severe condition (100% cold spring, whether such is used or not), lb and in.-lb (N and mm·N)

R_c, R_h = maximum reactions estimated to occur in the cold and hot conditions, respectively, lb and in.-lb (N and mm·N)

S_E = computed thermal expansion stress range, psi (MPa)

S_h = basic material allowable stress at maximum (hot) temperature, without the 20 ksi limitation as noted in para. 102.3.2(B)

If a piping system is designed with different percentages of cold spring in various directions, eqs. (18) and (19) are not applicable. In this case, the piping system shall be analyzed by a comprehensive method. The calculated hot reactions shall be based on theoretical cold springs in all directions not greater than two-thirds of the cold springs as specified or measured.

119.10.2 Reaction Limits. The reactions computed shall not exceed limits that the attached equipment can

⁴ The stress-intensification factors in Mandatory Appendix D have been developed from fatigue tests of representative commercially available, matching product forms and assemblies manufactured from ductile ferrous materials. The allowable stress range is based on tests of carbon and stainless steels. Caution should be exercised when applying eqs. (1) and (13) for the allowable stress range for certain nonferrous materials (e.g., copper and aluminum alloys) for other than low-cycle applications.

sustain. Equipment allowable reaction limits (forces and moments) on piping connections are normally established by the equipment manufacturer.

120 LOADS ON PIPE-SUPPORTING ELEMENTS

120.1 General

(A) The broad terms “supporting elements” or “supports” as used herein shall encompass the entire range of the various methods of carrying the weight of pipe lines, insulation, and the fluid carried. It, therefore, includes “hangers” that are generally considered as those elements that carry the weight from above, with the supporting members being mainly in tension. Likewise, it includes “supports” that on occasion are delineated as those that carry the weight from below, with the supporting members being mainly in compression. In many cases a supporting element may be a combination of both of these.

(B) In addition to the weight effects of piping components, consideration shall be given in the design of pipe supports to other load effects introduced by service pressure, wind, earthquake, etc., as defined in para. 101. Hangers and supporting elements shall be fabricated and assembled to permit the free movement of piping caused by thermal expansion and contraction. The design of elements for supporting or restraining piping systems, or components thereof, shall be based on all the concurrently acting loads transmitted into the supporting elements.

(C) Where the resonance with imposed vibration and/or shock occurs during operation, suitable dampeners, restraints, anchors, etc., shall be added to remove these effects.

120.2 Supports, Anchors, and Guides

120.2.1 Rigid-Type Supports

(A) The required strength of all supporting elements shall be based on the loadings as given in para. 120.1, including the weight of the fluid transported or the fluid used for testing, whichever is heavier. The allowable stress in supporting equipment shall be as specified in para. 121.2.

(B) Exceptions may be made in the case of supporting elements for large size gas or air piping, exhaust steam, relief or safety valve relief piping, but only under the conditions where the possibility of the line becoming full of water or other liquid is very remote.

120.2.2 Variable and Constant Supports. Load calculations for variable and constant supports, such as springs or counterweights, shall be based on the design operating conditions of the piping. They shall not include the weight of the hydrostatic test fluid. However, the support shall be capable of carrying the total load under test conditions, unless additional support is provided during the test period.

120.2.3 Anchors or Guides. Where anchors or guides are provided to restrain, direct, or absorb piping movements, their design shall take into account the forces and moments at these elements caused by internal pressure and thermal expansion.

120.2.4 Supplementary Steel. Where it is necessary to frame structural members between existing steel members, such supplementary steel shall be designed in accordance with American Institute of Steel Construction specifications, or similar recognized structural design standards. Increases of allowable stress values shall be in accordance with the structural design standard being used. Additional increases of allowable stress values, such as allowed in para. 121.2(I), are not permitted.

121 DESIGN OF PIPE-SUPPORTING ELEMENTS

121.1 General

Design of standard pipe-supporting elements shall be in accordance with the rules of MSS SP-58. Allowable stress values and other design criteria shall be in accordance with this paragraph. Supporting elements shall be capable of carrying the sum of all concurrently acting loads as listed in para. 120. They shall be designed to provide the required supporting effort and allow pipeline movement with thermal changes without causing overstress. The design shall also prevent complete release of the piping load in the event of spring failure or misalignment. All parts of the supporting equipment shall be fabricated and assembled so that they will not be disengaged by movement of the supported piping. The maximum safe loads for bolts, threaded hanger rods, and all other threaded members shall be based on the root area of the threads. MSS SP-58 may be used for guidance with respect to selection and application of pipe hangers and supports.

121.2 Allowable Stress Values

(A) Allowable stress values tabulated in MSS SP-58 or in Mandatory Appendix A of this Code Section may be used for the base materials of all parts of pipe-supporting elements.

(B) Where allowable stress values for a material specification listed in Table 126.1 are not tabulated in Mandatory Appendix A or in MSS SP-58, allowable stress values from Section II, Part D, Tables 1A and 1B of the ASME Boiler and Pressure Vessel Code may be used, provided the requirements of para. 102.3.1(B) are met. Where there are no stress values given in Section II, Part D, Tables 1A and 1B, an allowable stress value of 25% of the minimum tensile strength given in the material specification may be used, for temperatures not exceeding 650°F (345°C).

(C) For a steel material of unknown specification, or of a specification not listed in Table 126.1 or MSS SP-58,

an allowable stress value of 30% of yield strength (0.2% offset) at room temperature may be used at temperatures not exceeding 650°F (345°C). The yield strength shall be determined through a tensile test of a specimen of the material and shall be the value corresponding to 0.2% permanent strain (offset) of the specimen. The allowable stress values for such materials shall not exceed 9,500 psi (65.5 MPa).

(D) The allowable shear stress shall not exceed 80% of the values determined in accordance with the rules of (A), (B), and (C) above.

(E) The allowable compressive stress shall not exceed the value as determined in accordance with the rules of (A), (B), or (C) above. In addition, consideration shall be given to structural stability.

(F) The allowable bearing stress shall not exceed 160% of the value as determined in accordance with the rules of (A), (B), or (C) above.

(G) The allowable stress in tension determined from (A), (B), or (C) above shall be reduced 25% for threaded hanger rods.

(H) The allowable stress in partial penetration or fillet welds in support assemblies shall be reduced 25% from those determined in accordance with (A), (B), (C), or (D) above for the weaker of the two metals joined.

(I) If materials for attachments have different allowable stress values than the pipe, then the allowable stress for the weld shall be based on the lower allowable stress of the materials being joined.

(J) Increases in the allowable stress values shall be permitted as follows:

(J.1) an increase of 20% for short time overloading during operation.

(J.2) an increase to 80% of the minimum yield strength at room temperature during hydrostatic testing. Where the material allowable stress has been established in accordance with the rules of (C) above, the allowable stress value during hydrostatic testing shall not exceed 16,000 psi (110.3 MPa).

121.3 Temperature Limitations

Parts of supporting elements that are subjected principally to bending or tension loads and that are subjected to working temperatures for which carbon steel is not recommended shall be made of suitable alloy steel, or shall be protected so that the temperature of the supporting member will be maintained within the appropriate temperature limits of the material.

(16) 121.4 Hanger Adjustments

Hangers used for the support of piping, NPS 2½ (DN 65) and larger, shall be designed to permit adjustment after erection while supporting the load. Screwed adjustments shall have threaded parts to conform to ASME B1.1.

Table 121.5 Suggested Steel Pipe Support Spacing (16)

Nominal Pipe Size, NPS	Diameter Nominal, DN	Suggested Maximum Span			
		Water Service		Steam, Gas, or Air Service	
		ft	m	ft	m
1	25	7	2.1	9	2.7
2	50	10	3.0	13	4.0
3	80	12	3.7	15	4.6
4	100	14	4.3	17	5.2
6	150	17	5.2	21	6.4
8	200	19	5.8	24	7.3
12	300	23	7.0	30	9.1
16	400	27	8.2	35	10.7
20	500	30	9.1	39	11.9
24	600	32	9.8	42	12.8

GENERAL NOTES:

- Suggested maximum spacing between pipe supports for horizontal straight runs of standard and heavier steel pipe at maximum operating temperature of 750°F (400°C).
- Does not apply where span calculations are made or where there are concentrated loads between supports, such as flanges, valves, specialties, etc.
- The spacing is based on a fixed beam support with a bending stress not exceeding 2,300 psi (15.86 MPa) and insulated pipe filled with water or the equivalent weight of steel pipe for steam, gas, or air service, and the pitch of the line is such that a sag of 0.1 in. (2.5 mm) between supports is permissible.

Class 2 fit turnbuckles and adjusting nuts shall have the full length of thread in engagement. Means shall be provided for determining that full thread length is in engagement. All screw and equivalent adjustments shall be provided with suitable locking devices.

121.5 Hanger Spacing

Supports for piping with the longitudinal axis in approximately a horizontal position shall be spaced to prevent excessive sag, bending and shear stresses in the piping, with special consideration given where components, such as flanges and valves, impose concentrated loads. Where calculations are not made, suggested maximum spacing of supports for standard and heavier steel pipe are given in Table 121.5. Vertical supports shall be spaced to prevent the pipe from being overstressed from the combination of all loading effects.

121.6 Springs

The springs used in variable or constant effort type supports shall be designed and manufactured in accordance with MSS SP-58.

121.7 Fixtures

121.7.1 Anchors and Guides

(A) Anchors, guides, pivots, and restraints shall be designed to secure the desired points of piping in relatively fixed positions. They shall permit the piping to expand and contract freely in directions away from the anchored or guided point and shall be structurally suitable to withstand the thrusts, moments, and other loads imposed.

(B) Rolling or sliding supports shall permit free movement of the piping, or the piping shall be designed to include the imposed load and frictional resistance of these types of supports, and dimensions shall provide for the expected movement of the supported piping. Materials and lubricants used in sliding supports shall be suitable for the metal temperature at the point of sliding contact.

(C) Where corrugated or slip-type expansion joints, or flexible metal hose assemblies are used, anchors and guides shall be provided where necessary to direct the expansion into the joint or hose assembly. Such anchors shall be designed to withstand the force specified by the manufacturer for the design conditions at which the joint or hose assembly is to be used. If this force is otherwise unknown, it shall be taken as the sum of the product of the maximum internal area times the design pressure plus the force required to deflect the joint or hose assembly. Where expansion joints or flexible metal hose assemblies are subjected to a combination of longitudinal and transverse movements, both movements shall be considered in the design and application of the joint or hose assembly.

Flexible metal hose assemblies, applied in accordance with para. 106.4, shall be supported in such a manner as to be free from any effects due to torsion and undue strain as recommended by the manufacturer.

(16) 121.7.2 Other Rigid Types

(A) *Hanger Rods.* Safe loads for threaded hanger rods shall be based on the root area of the threads and 75% of the allowable stress of the material as provided in para. 121.2(G). In no case shall hanger rods less than $\frac{3}{8}$ in. (9.5 mm) diameter be used for support of pipe NPS 2 (DN 50) and smaller, or less than $\frac{1}{2}$ in. (12.5 mm) diameter rod for supporting pipe NPS $2\frac{1}{2}$ (DN 65) and larger. See Table 121.7.2(A) for carbon steel rods.

Pipe, straps, or bars of strength and effective area equal to the equivalent hanger rod may be used instead of hanger rods.

Hanger rods, straps, etc., shall be designed to permit the free movement of piping caused by thermal expansion and contraction.

(B) Welded link chain of $\frac{3}{16}$ in. (5.0 mm) or larger diameter stock, or equivalent area, may be used for pipe hangers with a design stress of 9,000 psi (62 MPa) maximum.

(C) Cast iron in accordance with ASTM A48 may be used for bases, rollers, anchors, and parts of supports where the loading will be mainly compression. Cast iron parts shall not be used in tension.

(D) Malleable iron castings in accordance with ASTM A47 may be used for pipe clamps, beam clamps, hanger flanges, clips, bases, swivel rings, and parts of pipe supports, but their use shall be limited to temperatures not in excess of 450°F (230°C). This material is not recommended for services where impact loads are anticipated.

(E) Brackets shall be designed to withstand forces and moments induced by sliding friction in addition to other loads.

121.7.3 Variable Supports

(A) Variable spring supports shall be designed to exert a supporting force equal to the load, as determined by weight balance calculations, plus the weight of all hanger parts (such as clamp, rod, etc.) that will be supported by the spring at the point of attachment to the pipe.

(B) Variable spring supports shall be provided with means to limit misalignment, buckling, eccentric loading, or to prevent overstressing of the spring.

(C) It is recommended that all hangers employing springs be provided with means to indicate at all times the compression of the spring with respect to the approximate hot and cold positions of the piping system, except where they are used either to cushion against shock or where the operating temperature of the piping system does not exceed 250°F (120°C).

(D) It is recommended that the support be designed for a maximum variation in supporting effort of 25% for the total travel resulting from thermal movement.

121.7.4 Constant Supports. On high temperature and critical service piping at locations subject to appreciable movement with thermal changes, the use of constant support hangers, designed to provide a substantially uniform supporting force throughout the range of travel, is recommended.

(A) Constant support hangers shall have a support variation of no more than 6% throughout the total travel range.

(B) Counterweight type supports shall be provided with stops, and the weights shall be positively secured. Chains, cables, hanger and rocker arm details, or other devices used to attach the counterweight load to the piping, shall be subject to requirements of para. 121.7.2.

(C) Hydraulic type supports utilizing a hydraulic head may be installed to give a constant supporting effort. Safety devices and stops shall be provided to support the load in case of hydraulic failure.

(D) Boosters may be used to supplement the operation of constant support hangers.

Table 121.7.2(A) Carrying Capacity of Threaded ASTM A36, A575, and A576 Hot-Rolled Carbon Steel

Nominal Rod Diameter, in.	Root Area of Thread, in. ²	Max. Safe Load at Rod Temp. of 650°F (343°C)	
		lb	kN
3/8	0.0678	730	3.23
1/2	0.126	1,350	5.98
5/8	0.202	2,160	9.61
3/4	0.302	3,230	14.4
7/8	0.419	4,480	19.9
1	0.551	5,900	26.2
1 1/4	0.890	9,500	42.4
1 1/2	1.29	13,800	61.6
1 3/4	1.74	18,600	82.8
2	2.30	24,600	109
2 1/4	3.02	32,300	144
2 1/2	3.72	39,800	177
2 3/4	4.62	49,400	220
3	5.62	60,100	267
3 1/4	6.72	71,900	320
3 1/2	7.92	84,700	377
3 3/4	9.21	98,500	438
4	10.6	114,000	505
4 1/4	12.1	129,000	576
4 1/2	13.7	146,000	652
4 3/4	15.4	165,000	733
5	17.2	184,000	819

GENERAL NOTES:

- (a) Tabulated loads are based on a minimum tensile stress of 50 ksi (345 MPa) divided by a safety factor of 3.5, reduced by 25%, resulting in an allowable stress of 10.7 ksi.
- (b) Root areas of thread are based upon the following thread series: diameters 4 in. and below — coarse thread (UNC); diameters above 4 in. — 4 thread (4-UN).
- (c) The corresponding table for metric size rods is available in MSS SP-58.

121.7.5 Sway Braces. Sway braces or vibration dampeners shall be used to control the movement of piping due to vibration.

121.7.6 Shock Suppressors. For the control of piping due to dynamic loads, hydraulic or mechanical types of shock suppressors are permitted. These devices do not support pipe weight.

121.8 Structural Attachments

121.8.1 Nonintegral Type

(A) Nonintegral attachments include clamps, slings, cradles, saddles, straps, and clevises.

(B) When clamps are used to support vertical lines, it is recommended that shear lugs be welded to the pipe to prevent slippage. The provisions of para. 121.8.2(B) shall apply.

(C) In addition to the provision of (B) above, clamps to support vertical lines should be designed to support

the total load on either arm in the event the load shifts due to pipe and/or hanger movement.

121.8.2 Integral Type

(A) Integral attachments include ears, shoes, lugs, cylindrical attachments, rings, and skirts that are fabricated so that the attachment is an integral part of the piping component. Integral attachments shall be used in conjunction with restraints or braces where multiaxial restraint in a single member is to be maintained. Consideration shall be given to the localized stresses induced into the piping component by the integral attachments. Where applicable, the conditions of para. 121.8.1(C) are to apply.

(B) Integral lugs, plates, angle clips, etc., used as part of an assembly for the support or guiding of pipe may be welded directly to the pipe provided the materials are compatible for welding and the design is adequate for the temperature and load. The design of hanger lugs

for attachment to piping for high temperature service shall be such as to provide for differential expansion between the pipe and the attached lug.

121.9 Loads and Supporting Structures

Considerations shall be given to the load carrying capacity of equipment and the supporting structure. This may necessitate closer spacing of hangers on lines with extremely high loads.

121.10 Requirements for Fabricating Pipe Supports

Pipe supports shall be fabricated in accordance with the requirements of para. 130.

PART 6 SYSTEMS

122 DESIGN REQUIREMENTS PERTAINING TO SPECIFIC PIPING SYSTEMS

Except as specifically stated otherwise in this Part 6, all provisions of the Code apply fully to the piping systems described herein.

122.1 Boiler External Piping; in Accordance With Para. 100.1.2(A) — Steam, Feedwater, Blowoff, and Drain Piping

- (16) **122.1.1 General.** The minimum pressure and temperature and other special requirements to be used in the design for steam, feedwater, blowoff, and drain piping from the boiler to the valve or valves required by para. 122.1 shall be as specified in the following paragraphs. Design requirements for desuperheater spray piping connected to desuperheaters located in the boiler proper and in main steam piping are provided in para. 122.4.

(A) It is intended that the design pressure and temperature be selected sufficiently in excess of any expected operating conditions, not necessarily continuous, to permit satisfactory operation without operation of the overpressure protection devices. Also, since the operating temperatures of fired equipment can vary, the expected temperature at the connection to the fired equipment shall include the manufacturer's maximum temperature tolerance.

(B) In a forced flow steam generator with no fixed steam and water line, it is permissible to design the external piping, valves, and fittings attached to the pressure parts for different pressure levels along the path through the steam generator of water-steam flow. The values of design pressure and the design temperature to be used for the external piping, valves, and fittings shall be not less than that required for the expected maximum sustained operating pressure and temperature to which the abutted pressure part is subjected except when one or more of the overpressure protection devices covered by PG-67.4 of Section I of the ASME

Boiler and Pressure Vessel Code is in operation. The steam piping shall comply with the requirements for the maximum sustained operating conditions as used in (A) above, or for the design throttle pressure plus 5%, whichever is greater.

(C) Provision shall be made for the expansion and contraction of piping connected to boilers to limit forces and moments transmitted to the boiler, by providing substantial anchorage at suitable points, so that there shall be no undue strain transmitted to the boiler. Steam reservoirs shall be used on steam mains when heavy pulsations of the steam currents cause vibration.

(D) Piping connected to the outlet of a boiler for any purpose shall be attached by

(D.1) welding to a nozzle or socket welding fitting

(D.2) threading into a tapped opening with a threaded fitting or valve at the other end

(D.3) screwing each end into tapered flanges, fittings, or valves with or without rolling or peening

(D.4) bolted joints including those of the Van Stone type

(D.5) blowoff piping of firetube boilers shall be attached in accordance with (D.2) above if exposed to products of combustion or in accordance with (D.2), (D.3), or (D.4) above if not so exposed

(E) Nonferrous pipe or tubes shall not exceed NPS 3 (DN 80) in diameter.

(F) American National Standard slip-on flanges shall not exceed NPS 4 (DN 100). Attachment of slip-on flanges shall be by double fillet welds. The throats of the fillet welds shall not be less than 0.7 times the thickness of the part to which the flange is attached.

(G) Hub-type flanges shall not be cut from plate material.

(H) American National Standard socket welded flanges may be used in piping or boiler nozzles provided the dimensions do not exceed NPS 3 (DN 80) for Class 600 and lower, and NPS 2½ (DN 65) in Class 1500.

(I) The use of expansion joints of all types, swivel and ball joints, and flexible metal hose assemblies as described in para. 101.7.2 is prohibited.

122.1.2 Steam Piping

(A) The value of P to be used in the formulas in para. 104 shall be as follows:

(A.1) For steam piping connected to the steam drum or to the superheater inlet header up to the first stop valve in each connection, the value of P shall be not less than the lowest pressure at which any drum safety valve is set to blow, and the S value shall not exceed that permitted for the corresponding saturated steam temperature.

(A.2) For steam piping connected to the superheater outlet header up to the first stop valve in each connection, the design pressure, except as otherwise provided in (A.4) below shall be not less than the lowest

pressure at which any safety valve on the superheater is set to blow, or not less than 85% of the lowest pressure at which any drum safety valve is set to blow, whichever is greater, and the S value for the material used shall not exceed that permitted for the expected steam temperature.

(A.3) For steam piping between the first stop valve and the second valve, when one is required by para. 122.1.7, the design pressure shall be not less than the expected maximum sustained operating pressure or 85% of the lowest pressure at which any drum safety valve is set to blow, whichever is greater, and the S value for the material used shall not exceed that permitted for the expected steam temperature.

(A.4) For boilers installed on the unit system (i.e., one boiler and one turbine or other prime mover) and provided with automatic combustion control equipment responsive to steam header pressure, the design pressure for the steam piping shall be not less than the design pressure at the throttle inlet plus 5%, or not less than 85% of the lowest pressure at which any drum safety valve is set to blow, or not less than the expected maximum sustained operating pressure at any point in the piping system, whichever is greater, and the S value for the material used shall not exceed that permitted for the expected steam temperature at the superheater outlet. For forced-flow steam generators with no fixed steam and water line, the design pressure shall also be no less than the expected maximum sustained operating pressure.

(A.5) The design pressure shall not be taken at less than 100 psig [700 kPa (gage)] for any condition of service or material.

122.1.3 Feedwater Piping

(A) The value of P to be used in the formulas in para. 104 shall be as follows:

(A.1) For piping from the boiler to and including the required stop valve and the check valve, the minimum value of P except as permitted in para. 122.1.3(A.4) shall exceed the maximum allowable working pressure of the boiler by either 25% or 225 psi (1 550 kPa), whichever is the lesser. For an installation with an integral economizer without valves between the boiler and economizer, this paragraph shall apply only to the piping from the economizer inlet header to and including the required stop valve and the check valve.

(A.2) For piping between the required check valve and the globe or regulating valve, when required by para. 122.1.7(B), and including any bypass piping up to the shutoff valves in the bypass, the value of P shall be not less than the pressure required to feed the boiler.

(A.3) The value of P in the formula shall not be taken at less than 100 psig [700 kPa (gage)] for any condition of service or material, and shall never be less than the pressure required to feed the boiler.

(A.4) In a forced flow steam generator with no fixed steam and water line, the value of P for feedwater piping from the boiler to and including the required stop valve may be in accordance with the requirements of para. 122.1.1(B).

(B) The S value used, except as permitted in (A.4) above, shall not exceed that permitted for the temperature of saturated steam at the maximum allowable working pressure of the boiler.

(C) The size of the feed piping between the boiler and the first required valve [para. 122.1.7(B)] or the branch feed connection [para. 122.1.7(B.4)] shall, as a minimum, be the same as the boiler connection.

122.1.4 Blowoff and Blowdown Piping. Blowoff and blowdown piping are defined as piping connected to a boiler and provided with valves or cocks through which the water in the boiler may be blown out under pressure. This definition is not intended to apply to (i) drain piping, and (ii) piping such as used on water columns, gage glasses, or feedwater regulators, etc., for the purpose of determining the operating condition of the equipment. Requirements for (i) and (ii) are described in paras. 122.1.5 and 122.1.6, respectively. Blowoff systems are operated intermittently to remove accumulated sediment from equipment and/or piping, or to lower boiler water level in a rapid manner. Blowdown systems are primarily operated continuously to control the concentrations of dissolved solids in the boiler water.

(A) Blowoff piping systems from water spaces of a boiler, up to and including the blowoff valves, shall be designed in accordance with (A.1) to (A.4) below. Two shutoff valves are required in the blowoff system; specific valve requirements and exceptions are given in para. 122.1.7(C).

(A.1) The value of P to be used in the formulas in para. 104 shall exceed the maximum allowable working pressure of the boiler by either 25% or 225 psi (1 550 kPa) whichever is less, but shall be not less than 100 psig [690 kPa (gage)]. The exception to this requirement pertains to miniature boilers as described in Section I, Parts PEB and PMB of the ASME Boiler and Pressure Vessel Code, where the value of P to be used in the formulas in para. 104 shall be 100 psi [690 kPa (gage)].

(A.2) The allowable stress value for the piping materials shall not exceed that permitted for the temperature of saturated steam at the maximum allowable working pressure of the boiler.

(A.3) All pipe shall be steel except as permitted below. Galvanized steel pipe and fittings shall not be used for blowoff piping. When the value of P does not exceed 100 psig [690 kPa (gage)], nonferrous pipe may be used and the fittings may be bronze, cast iron, malleable iron, ductile iron, or steel.

CAUTION: Nonferrous alloys and austenitic stainless steels may be sensitive to stress corrosion cracking in certain aqueous environments.

When the value of P exceeds 100 psig [690 kPa (gage)], the fittings shall be steel, and the thickness of pipe and fittings shall not be less than that of Schedule 80 pipe.

(A.4) The size of blowoff piping shall be not less than the size of the connection on the boiler, and shall be in accordance with the rules contained in the ASME Boiler and Pressure Vessel Code, Section I, PG-59.3, PMB-12, and PEB-12.

(B) The blowdown piping system from the boiler, to and including the shutoff valve, shall be designed in accordance with (B.1) through (B.4) below. Only one shutoff valve is required in the blowdown system.

(B.1) The value of P to be used in the formulas in para. 104 shall be not less than the lowest set pressure of any safety valve on the boiler drum.

(B.2) The allowable stress value for the piping materials shall not exceed that permitted for the temperature of saturated steam at the maximum allowable working pressure of the boiler.

(B.3) All pipe shall be steel except as permitted below. Galvanized steel pipe and fittings shall not be used for blowdown piping. When the value of P does not exceed 100 psig [690 kPa (gage)], nonferrous pipe may be used and the fittings may be bronze, cast iron, malleable iron, ductile iron, or steel.

CAUTION: Nonferrous alloys and austenitic stainless steels may be sensitive to stress corrosion cracking in certain aqueous environments.

When the value of P exceeds 100 psig [690 kPa (gage)], the fittings shall be steel and the thickness of pipe and fittings shall not be less than that of Schedule 80 pipe.

(B.4) The size of blowdown piping shall be not less than the size of the connection on the boiler, and shall be in accordance with the rules contained in the ASME Boiler and Pressure Vessel Code, Section I, PG-59.3, PMB-12, and PEB-12.

(C) The blowoff and blowdown piping beyond the required valves described in (A) and (B) above are classified as nonboiler external piping. The requirements are given in para. 122.2.

122.1.5 Boiler Drains

(A) Complete drainage of the boiler and attached piping shall be provided to the extent necessary to ensure proper operation of the steam supply system. The pipe, fittings, and valves of any drain line shall not be smaller than the drain connection. Double valving shall be required for each boiler drain connection except as permitted in (C) and (D) below.

(B) If the drain lines are intended to be used both as drains and as blowoffs, then two valves are required and all conditions of paras. 122.1.4, 122.1.7(C), and 122.2 shall be met.

(C) Miniature boilers constructed in accordance with the rules contained in the ASME Boiler and Pressure Vessel Code, Section I, Parts PMB and PEB may use a

single valve where drain lines are intended to be used for both blowoff and periodic automatic or manual flushing prior to startup. The single valve shall be designed for blowoff service but need not have locking capability.

(D) When a drain is intended for use only when the boiler is not under pressure (pressurizing the boiler for rapid drainage is an exception), a single shutoff valve is acceptable under the following conditions: either the valve shall be a type that can be locked in the closed position, or a suitable flanged and bolted connection that accepts a blank insert shall be located on the downstream side of the valve. When a single valve is used, it need not be designed for blowoff service. Single valves on miniature boilers constructed in accordance with the rules contained in the ASME Boiler and Pressure Vessel Code, Section I, Parts PMB and PEB do not require locking capability.

(E) Drain piping from the drain connection, including the required valve(s) or the blanked flange connection, shall be designed for the temperature and pressure of the drain connection. The remaining piping shall be designed for the expected maximum temperature and pressure. Static head and possible choked flow conditions shall be considered. In no case shall the design pressure and temperature be less than 100 psig [690 kPa (gage)] and 220°F (105°C), respectively.

122.1.6 Boiler External Piping – Miscellaneous Systems

(A) Materials, design, fabrication, examination, and erection of piping for miscellaneous accessories, such as water level indicators, water columns, gage cocks, and pressure gages, shall be in accordance with the applicable sections of this Code.

(B) The value of P to be used in the formulas in para. 104 shall be not less than the maximum allowable working pressure of the boiler except as provided by para. 122.1.1(B).

(C) Valve requirements for water level indicators or water columns, special gage glass and gage cock requirements, minimum line sizes, and special piping configurations required specifically for cleaning, access, or reliability shall be in accordance with PG-60 of Section I of the ASME Boiler and Pressure Vessel Code.

122.1.7 Valves and Fittings. The minimum pressure and temperature rating for all valves and fittings in steam, feedwater, blowoff, and miscellaneous piping shall be equal to the pressure and temperature specified for the connected piping on the side that has the higher pressure, except that in no case shall the pressure be less than 100 psig [690 kPa (gage)], and for pressures not exceeding 100 psig [690 kPa (gage)] in feedwater and blowoff service, the valves and fittings shall be equal at least to the requirements of the ASME standards for Class 125 cast iron or bronze, or Class 150 steel or bronze.

(A) *Steam Stop Valves.* Each boiler discharge outlet, except safety valve or safety relief valve connections, or

reheater inlet and outlet connections, shall be fitted with a stop valve located at an accessible point in the steam-delivery line and as near to the boiler nozzle as is convenient and practicable.

(A.1) Boiler stop valves shall provide bidirectional shutoff at design conditions. The valve or valves shall meet the requirements of para. 107. Valves with resilient (nonmetallic) seats shall not be used where the boiler maximum allowable working pressure exceeds 150 psig (1 035 kPa) or where the system design temperature exceeds 366°F (186°C). Valves of the outside screw and yoke, rising stem style are preferred. Valves other than those of the outside screw and yoke, rising stem style shall meet the following additional requirements:

(A.1.1) Each valve shall be equipped with a position indicator to visually indicate from a distance whether the valve is open or closed.

(A.1.2) Quarter turn valves shall be equipped with a slow operating mechanism to minimize dynamic loadings on the boiler and attached piping. Either a quick-opening manual quarter-turn valve or an automatic solenoid valve may be used on miniature boilers constructed in accordance with the rules contained in the ASME Boiler and Pressure Vessel Code, Section I, Parts PMB and PEB. Manual quarter-turn valves shall be provided with a handle or other position indicator to indicate from a distance whether the valve is open or closed.

(A.2) In the case of a single boiler and prime mover installation, the stop valve required herein may be omitted provided the prime mover throttle valve is equipped with an indicator to show whether it is opened or closed, and it is designed to withstand the required boiler hydrostatic test.

(A.3) When two or more boilers are connected to a common header, or when a single boiler is connected to a header having another steam source, the connection from each boiler having a manhole opening shall be fitted with two stop valves having an ample free-blow drain between them. The preferred arrangement consists of one stop-check valve (located closest to the boiler) and one valve of the style and design described in (A.1) above. Alternatively, both valves may be of the style and design described in (A.1) above.

When a second stop valve is required, it shall have a pressure rating at least equal to that required for the expected steam pressure and temperature at the valve, or a pressure rating at least equal to 85% of the lowest set pressure of any safety valve on the boiler drum at the expected temperature of the steam at the valve, whichever is greater.

(A.4) All valves and fittings on steam lines shall have a pressure rating of at least 100 psig [690 kPa (gage)] in accordance with the applicable ASME standard.

(B) Feedwater Valves

(B.1) The feedwater piping for all boilers, except for high temperature water boilers complying with the

requirements of (B.8) below, and for forced flow steam generators with no fixed steam and water line complying with the requirements of (B.9) below, shall be provided with a check valve and a stop valve or cock between the check valve and the boiler. The stop valve or cock shall comply with the requirements of (C.5) below.

(B.2) The relative locations of the check and stop (or cock) valves, as required in (B.1) above, may be reversed on a single boiler-turbine unit installation.

(B.3) If a boiler is equipped with a duplicate feed arrangement, each such arrangement shall be equipped as required by these rules.

(B.4) When the supply line to a boiler is divided into branch feed connections and all such connections are equipped with stop and check valves, the stop and check valves in the common source may be omitted.

(B.5) When two or more boilers are fed from a common source, there shall also be a globe or regulating valve in the branch to each boiler located between the check valve and the source of supply. A typical arrangement is shown in Fig. 100.1.2(B.1).

(B.6) A combination stop and check valve in which there is only one seat and disk, and in which a valve stem is provided to close the valve, shall be considered only as a stop valve, and a check valve shall be installed as otherwise provided.

(B.7) Where an economizer or other feedwater heating device is connected directly to the boiler without intervening valves, the feed valves and check valves required shall be placed on the inlet of the economizer or feedwater heating device.

(B.8) The recirculating return line for a high temperature water boiler shall be provided with the same stop valve, or valves, required by (B.1) and (B.3) above. The use of a check valve in the recirculating return line is optional. A check valve shall not be a substitute for a stop valve.

(B.9) The feedwater boiler external piping for a forced flow steam generator with no fixed steam and water line may terminate up to and including the stop valve(s) and omitting the check valve(s) provided that a check valve having a pressure rating no less than the boiler inlet design pressure is installed at the discharge of each boiler feed pump or elsewhere in the feedline between the feed pump and the stop valve(s).

(B.10) Wherever globe valves are used within BEP feedwater piping for either isolation or regulation, the inlet shall be under the disk of the valve.

(C) Blowoff Valves

(C.1) Ordinary globe valves as shown in Fig. 122.1.7(C), illustration (a), and other types of valves that have dams or pockets where sediment can collect, shall not be used on blowoff connections.

(C.2) Y-type globe valves as shown in Fig. 122.1.7(C), illustration (b) or angle valves may be

Fig. 122.1.7(C) Typical Globe Valves

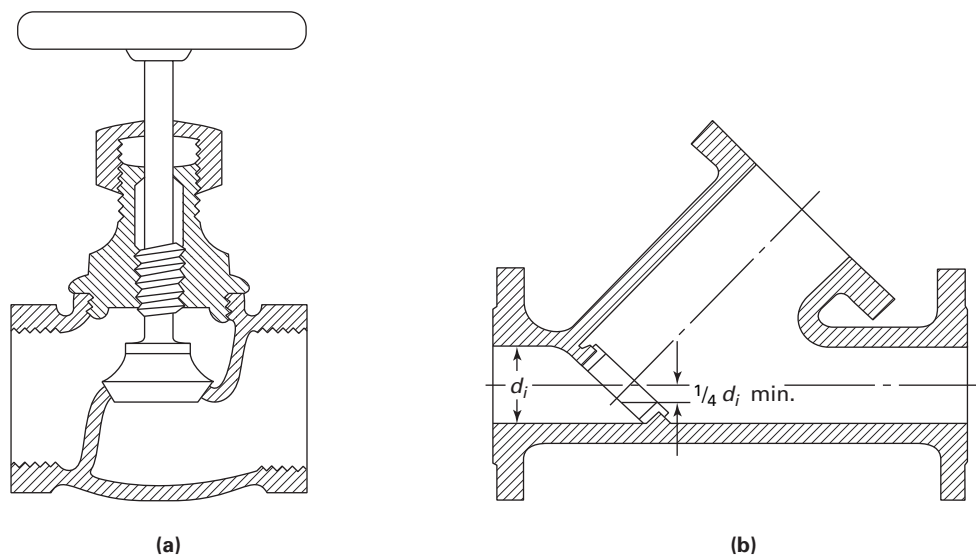

used in vertical pipes, or they may be used in horizontal runs of piping provided they are so constructed or installed that the lowest edge of the opening through the seat is at least 25% of the inside diameter below the centerline of the valve.

(C.3) The blowoff valve or valves, the pipe between them, and the boiler connection shall be of the same size except that a larger pipe for the return of condensate may be used.

(C.4) For all boilers [except electric steam boilers having a normal water content not exceeding 100 gal (380 L), traction-purpose, and portable steam boilers; see (C.11) and (C.12) below] with allowable working pressure in excess of 100 psig [690 kPa (gage)], each bottom blowoff pipe shall have two slow-opening valves, or one quick-opening valve or cock, at the boiler nozzle followed by a slow-opening valve. All valves shall comply with the requirements of (C.5) and (C.6) below.

(C.5) When the value of P required by para. 122.1.4(A.1) does not exceed 250 psig [1 725 kPa (gage)], the valves or cocks shall be bronze, cast iron, ductile iron, or steel. The valves or cocks, if of cast iron, shall not exceed NPS 2½ (DN 65) and shall meet the requirements of the applicable ASME standard for Class 250, as given in Table 126.1, and if of bronze, steel, or ductile iron construction, shall meet the requirements of the applicable standards as given in Table 126.1 or para. 124.6.

(C.6) When the value of P required by para. 122.1.4(A.1) is higher than 250 psig [1 725 kPa (gage)], the valves or cocks shall be of steel construction equal at least to the requirements of Class 300 of the applicable

ASME standard listed in Table 126.1. The minimum pressure rating shall be equal to the value of P required by para. 122.1.4(A.1).

(C.7) If a blowoff cock is used, the plug shall be held in place by a guard or gland. The plug shall be distinctly marked in line with the passage.

(C.8) A slow-opening valve is a valve that requires at least five 360 deg turns of the operating mechanism to change from fully closed to fully opened.

(C.9) On a boiler having multiple blowoff pipes, a single master valve may be placed on the common blowoff pipe from the boiler, in which case only one valve on each individual blowoff is required. In such a case, either the master valve or the individual valves or cocks shall be of the slow-opening type.

(C.10) Two independent slow-opening valves, or a slow-opening valve and a quick-opening valve or cock, may be combined in one body and may be used provided the combined fitting is the equivalent of two independent slow-opening valves, or a slow-opening valve and a quick-opening valve or cock, and provided further that the failure of one to operate cannot affect the operation of the other.

(C.11) Only one blowoff valve, which shall be either a slow-opening or quick-opening blowoff valve or a cock, is required on traction and/or portable boilers.

(C.12) Only one blowoff valve, which shall be of a slow-opening type, is required for the blowoff piping for forced circulation and electric steam boilers having a normal water content not exceeding 100 gal (380 L). Electric boilers not exceeding a normal water content of 100 gal (380 L) and a maximum MAWP of 100 psig [690 kPa (gage)] may use a quick-opening manual or

Table 122.2 Design Pressure for Blowoff/Blowdown Piping Downstream of BEP Valves

Boiler or Vessel Pressure		Design Pressure [Note (1)]	
MAWP	kPa (gage)	psig	kPa (gage)
Below 250	1 725	Note (2)	Note (2)
250–600	1 725–4 135	250	1 725
601–900	4 136–6 205	400	2 760
901–1,500	6 206–10 340	600	4 135
1,501 and higher	10 341 and higher	900	6 205

NOTES:

- (1) The allowable stress value for the piping material need not exceed that permitted for the temperature of saturated steam at the design pressure.
- (2) For boiler or vessel pressures below 250 psig [1 725 kPa (gage)], the design pressure shall be determined in accordance with para. 122.1.4(B.1), but need not exceed 250 psig [1 725 kPa (gage)].

slow-opening automatic quarter-turn valve up to NPS 1 (DN 25). Electric boilers not exceeding a normal water content of 100 gal (380 L) but with a MAWP greater than 100 psig [690 kPa (gage)] shall only use either a slow-opening type manual or automatic valve, regardless of size.

(D) Pressure-Relieving Valves

(D.1) Safety, safety-relief, and power-actuated pressure-relieving valves shall conform to the requirements of PG-67, PG-68, PG-69, PG-70, PG-71, PG-72, and PG-73 of Section I of the ASME Boiler and Pressure Vessel Code.

122.2 Blowoff and Blowdown Piping in Nonboiler External Piping

Blowoff and blowdown piping systems shall be, where possible, self-draining and without pockets. If unavoidable, valved drains at low points shall allow system draining prior to operation. In order to minimize pipeline shock during the operation of blowoff systems, 3D pipe bends (minimum) should be used in preference to elbows, and wye or lateral fittings should be used in preference to tee connections.

(A) From Boilers

(A.1) Blowoff piping, located between the valves described in para. 122.1.4(A) and the blowoff tank or other point where the pressure is reduced approximately to atmospheric pressure and cannot be increased by closing a downstream valve, shall be designed for the appropriate pressure in accordance with Table 122.2. The provisions of paras. 122.1.4(A.3) and 122.1.7 shall apply. The size of non-BEP blowoff header to the safe point of discharge shall not be smaller than the largest connected BEP blowoff terminal [see para. 122.1.4(A.4)].

(A.2) Blowdown piping, in which the pressure cannot be increased by closing a downstream valve, shall be designed for the appropriate pressure and temperature in accordance with Table 122.2. The provisions of

para. 122.1.4(B.3) shall apply. The size of non-BEP blowdown piping between the shutoff valve described in para. 122.1.4(B) and the flow control valve shall not be smaller than the BEP boiler shutoff valve [see para. 122.1.4(B.4)] unless engineering calculations confirm that the design flow rate can be achieved with a smaller piping size without flashing the blowdown prior to the flow control valve.

(A.3) When the design pressure of Table 122.2 can be exceeded due to closing of a downstream valve, calculated pressure drop, or other means, the entire blowoff or blowdown piping system shall be designed in accordance with paras. 122.1.4(A) and 122.1.7 for blowoff and para. 122.1.4(B) for blowdown piping.

(A.4) Non-BEP blowdown piping downstream of the flow control valve shall not be smaller — and preferably will be larger — than the connection on the boiler [see para. 122.1.4(B.4)].

(B) From Pressure Vessels Other Than Boilers

(B.1) The design pressure and temperature of the blowoff piping from the pressure vessel to and including the blowoff valve(s) shall not be less than the vessel MAWP and corresponding design temperature.

122.3 Instrument, Control, and Sampling Piping

(A) The requirements of this Code, as supplemented by para. 122.3, shall apply to the design of instrument, control, and sampling piping for safe and proper operation of the piping itself.

(B) The term “Instrument Piping” shall apply to all valves, fittings, tubing, and piping used to connect instruments to main piping or to other instruments or apparatus or to measuring equipment as used within the classification of para. 100.1.

(C) The term “Control Piping” shall apply to all valves, fittings, tubing, and piping used to interconnect pneumatically or hydraulically operated control apparatus, also classified in accordance with para. 100.1, as well

as to signal transmission systems used to interconnect instrument transmitters and receivers.

(D) The term "Sampling Piping" shall apply to all valves, fittings, tubing, and piping used for the collection of samples, such as steam, water, oil, gas, and chemicals.

(E) Paragraph 122.3 does not apply to tubing used in permanently closed systems, such as fluid-filled temperature responsive devices, or the temperature responsive devices themselves.

(F) Paragraph 122.3 does not apply to the devices, apparatus, measuring, sampling, signalling, transmitting, controlling, receiving, or collecting instruments to which the piping is connected.

122.3.1 Materials and Design. The materials utilized for valves, fittings, tubing, and piping shall meet the particular conditions of service and the requirements of the applicable specifications listed under general paras. 105, 106, 107, and 108 with allowable stresses in accordance with the Allowable Stress Tables in Mandatory Appendix A.

The materials for pressure retention components used for piping specialties such as meters, traps, and strainers in flammable, combustible, or toxic fluid systems shall in addition conform to the requirements of paras. 122.7 and 122.8.

(16) **122.3.2 Instrument Piping**

(A) *Takeoff Connections*

(A.1) Takeoff connections at the source, together with attachment bosses, nozzles, and adapters, shall be made of material at least equivalent to that of the pipe or vessel to which they are attached. The connections shall be designed to withstand the source design pressure and temperature and be capable of withstanding loadings induced by relative displacement and vibration. The nominal size of the takeoff connections shall not be less than NPS $\frac{1}{2}$ (DN 15) for service conditions not in excess of either 900 psi (6 200 kPa) or 800°F (425°C), and NPS $\frac{3}{4}$ (DN 20) (for adequate physical strength) for design conditions that exceed either of these limits. Where the size of the main is smaller than the limits given above, the takeoff connection shall not be less than the size of the main line.

(A.2) To prevent thermal shock to the main steam line by contact with the colder condensate return from the instrument, steam meter or instrument takeoff connections shall be lagged in with the steam main. For temperature in excess of 800°F (425°C), they may also be arranged to make metallic contact lengthwise with the steam main.

(B) *Valves*

(B.1) *Shutoff Valves.* Shutoff valves shall be provided at takeoff connections. They shall be capable of withstanding the design pressure and temperature of the pipe or vessel to which the takeoff adapters or nipples are attached.

(B.2) *Blowdown Valves*

(B.2.1) Blowdown valves at or near the instrument shall be of the gradual opening type. For subcritical pressure steam service, the design pressure for blowdown valves shall be not less than the design pressure of the pipe or vessel; the design temperature shall be the corresponding temperature of saturated steam. For all other services, blowdown valves shall meet the requirements of (B.1) above.

(B.2.2) When blowdown valves are used, the valves at the instrument as well as any intervening fittings and tubing between such blowdown valves and the meter shall be suitable at 100°F (40°C) for at least $1\frac{1}{2}$ times the design pressure of the piping system, but the rating of the valve at the instrument need not exceed the rating of the blowdown valve.

(B.2.3) When blowdown valves are not used, instrument valves shall conform to the requirements of (B.2.1) above.

(C) *Reservoirs or Condensers.* In dead end steam service, the condensing reservoirs and connecting nipples, which immediately follow the shutoff valves, shall be made of material suitable for the saturated steam temperature corresponding to the main line design pressure.

(D) *Materials for Lines Between Shutoff Valves and Instruments*

(D.1) Copper, copper alloys, and other nonferrous materials may be used in dead end steam or water services up to the design pressure and temperature conditions used for calculating the wall thickness in accordance with para. 104 provided that the temperature within the connecting lines for continuous services does not exceed 406°F (208°C).

Where water temperature in the reservoir of condensers is above 406°F (208°C), a length of uninsulated steel tubing at least 5 ft (1.5 m) long shall immediately follow the condenser ahead of the connecting copper tubing to the instrument.

(D.2) The minimum size of the tubing or piping is a function of its length, the volume of fluid required to produce full scale deflections of the instrument, and the service of the instrument. When required to prevent plugging as well as to obtain sufficient mechanical strength, the inside diameter of the pipe or tube should not be less than 0.36 in. (9.14 mm), with a wall thickness of not less than 0.049 in. (1.25 mm). When these requirements do not apply, smaller sizes with wall thickness in due proportions may be used. In either case, wall thickness of the pipe or tube shall meet the requirements of (D.3) below.

(D.3) The piping or tubing shall be designed in accordance with para. 104 with consideration for water hammer.

(E) *Fittings and Joints*

(E.1) For dead end steam service and for water above 150°F (65°C), fittings of the flared, flareless, or

socket welding type, or other suitable type of similar design shall be used. The fittings shall be suitable for the header pressure and corresponding saturated steam temperature or water temperature, whichever applies. For supercritical pressure conditions the fittings shall be suitable for the design pressure and temperature of the main fluid line.

(E.2) For water, oil and similar instrument services, any of the following types may be used, within the pressure–temperature limitations of each:

(E.2.1) For main line hydraulic pressures above 500 psi (3 450 kPa) and temperatures up to 150°F (65°C), steel fittings either of the flared, flareless, socket welded, fusion welded, or silver brazed socket type shall be used.

(E.2.2) For main line pressures up to 500 psi (3 450 kPa) and temperatures up to 150°F (65°C), the fittings may be flared or silver brazed socket type, inverted flared or flareless compression type, all of brass or bronze.

(E.2.3) For pressures up to 175 psi (1 200 kPa) or temperatures up to 250°F (120°C), soldered type fittings may be used with water-filled or air-filled tubing under adjusted pressure–temperature ratings. These fittings are not recommended where mechanical vibration, hydraulic shock, or thermal shock are encountered.

122.3.3 Control Piping

(A) Takeoff Connections

(A.1) Takeoff connections shall be in accordance with para. 122.3.2(A.1).

(B) Valves

(B.1) Shutoff valves shall be in accordance with para. 122.3.2(B.1).

(C) Materials

(C.1) The same materials may be used for control lines as for instrument lines, except that the minimum inside diameter shall be 0.178 in. (4.52 mm) with a minimum wall thickness of 0.028 in. (0.71 mm), provided that this wall thickness is not less than that required by para. 122.3.2(D.3). If a control device has a connection smaller than $\frac{1}{4}$ in. (6.0 mm), the size reduction from the control tubing to the control device shall be made as close to the control device as possible.

(D) Fittings and Joints

(D.1) Fittings and joints shall be in accordance with para. 122.3.2(E.2).

122.3.4 Sampling Piping

(A) Takeoff Connections

(A.1) Takeoff connections shall be in accordance with para. 122.3.2(A.1).

(B) Valves

(B.1) Shutoff valves shall be in accordance with para. 122.3.2(B.1).

(B.2) Blowdown valves shall be of the gradual opening type and shall be suitable for main line design pressure and temperature.

(C) Materials

(C.1) The materials to be used for sampling lines shall conform to minimum requirements for the main line to which they connect.

(D) Fittings and Joints

(D.1) For subcritical and supercritical pressure steam, and for water above 150°F (65°C), fittings of the flared, flareless, or socket welding type, or other suitable type of similar design shall be used. The fittings shall be suitable for main line design pressure and temperature.

(D.2) For water below 150°F (65°C), fittings and joints shall be suitable for main line design pressure and temperature and shall be in accordance with para. 122.3.2(E.2).

122.3.6 Fittings and Joints

(16)

(A) All fittings shall be in accordance with standards and specifications listed in Table 126.1.

(A.1) Socket welded joints shall comply with the requirements of para. 111.3.

(A.2) Flared, flareless, and compression type fittings and their joints shall comply with the requirements of para. 115.

(A.3) Silver brazed socket type joints shall comply with the requirements of paras. 117.1 and 117.3.

(A.4) Solder type joints shall comply with the requirements of paras. 117.2 and 117.3.

(A.5) The use of taper threaded joints up to and including NPS $\frac{1}{2}$ (DN 15) is permitted at pressures up to 5,000 psi (34 500 kPa) in dead-end service from outlet end and downstream of shutoff valve located at instrument, at control apparatus, or at discharge of sample cooler.

122.3.7 Special Safety Provisions

(A) Connecting piping subject to clogging from solids or deposits shall be provided with suitable connections for cleaning.

(B) Connecting piping handling air and gases containing moisture or other extraneous materials shall be provided with suitable drains or settling chambers or traps.

(C) Connecting piping that may contain liquids shall be protected from damage due to freezing by heating or other adequate means.

122.3.8 Supports.

Supports shall be furnished as specified in para. 121 not only for safety but also to protect the piping against detrimental sagging, external mechanical injury abuse, and exposure to unusual service conditions.

122.3.9 Installations

(A) Instrument, control, and sampling piping shall be inspected and tested in accordance with paras. 136 and 137.

(B) The inside of all piping, tubing, valves, and fittings shall be smooth, clean, and free from blisters, loose

mill scale, sand, and dirt when erected. All lines shall be cleaned after installation and before placing in service.

122.4 Spray-Type Desuperheater Piping for Use on Steam Generators, Main Steam, and Reheat Steam Piping

(A) Valves and Piping Arrangement

(A.1) Each spraywater pipe connected to a desuperheater shall be provided with a stop valve and a regulating (spray control) valve. The regulating valve shall be installed upstream of the stop valve. In addition, if the steam generator supplies steam to a steam turbine, a power-operated block valve⁵ shall be installed upstream of the regulating valve.

(A.2) A bypass valve around the regulating valve is permitted.

(A.3) A bypass valve around the power-operated block valve is prohibited.

(A.4) On a superheater or reheater desuperheater, a drain valve shall be installed between the power-operated block valve and the regulating valve.

(A.5) If the spraywater supply is from the boiler feedwater system and its source is not downstream of the feedwater check valve required by para. 122.1.7, a check valve shall be provided in the spraywater piping between the desuperheater and the spraywater source.

(A.6) It is recommended that the valves and piping be arranged to provide a head of water on the downstream side of the stop valve.

(A.7) A typical arrangement is shown in Fig. 122.4.

(A.8) Provisions shall be made to both steam and water systems to accommodate the operating conditions associated with this service including: water hammer, thermal shock and direct water impingement. The connection for the spraywater pipe should be located per the requirements established by the manufacturer so that complete flow mixing is achieved prior to any bends, elbows, or other flow directional changes being encountered.

(A.9) Insertable-type desuperheaters, which include an integral stop and spraywater regulating valve, may be used within the limitations established by the manufacturer. If this type is used, the individual stop and regulating valves shown in Fig. 122.4 may be omitted. All other requirements described in para. 122.4 shall apply.

(A.10) For Desuperheaters Located Within Main Steam or Reheat Steam Piping. The steam system to be desuperheated shall be provided with proper drainage during all water flow conditions. The drainage system shall function both manually and automatically.

(B) Design Requirements

(B.1) The value of P to be used in the formulas of para. 104 shall be as follows:

(B.1.1) For piping from the desuperheater back to the stop valve required by (A.1) above, the value of P shall be equal to or greater than the maximum allowable working pressure of the desuperheater.

(B.1.2) For the remainder of the spraywater piping system, the value of P shall be not less than the maximum sustained pressure exerted by the spraywater.

(B.2) The stop valve required by (A.1) above shall be designed for the pressure requirement of (B.1.1) above or the maximum sustained pressure exerted by the spraywater, whichever is greater.

(B.3) The S value used for the spraywater piping shall not exceed that permitted for the expected temperature.

NOTE: The temperature varies from that of the desuperheater to that of the spraywater source and is highly dependent on the piping arrangement. It is the responsibility of the designer to determine the design temperature to be used for the various sections of the piping system.

122.5 Pressure-Reducing Valves

122.5.1 General. Where pressure-reducing valves are used, one or more pressure-relieving valves or devices shall be provided on the low pressure side of the system. Otherwise, the piping and equipment on the low pressure side of the system shall be designed to withstand the upstream design pressure. The pressure-relieving valves or devices shall be located adjoining or as close as practicable to the reducing valve. The combined relieving capacity provided shall be such that the design pressure of the low pressure system will not be exceeded if the reducing valve fails open.

122.5.2 Bypass Valves. Hand-controlled bypass valves having a capacity no greater than the reducing valve may be installed around pressure-reducing valves if the downstream piping is protected by pressure-relieving valves or devices as required in para. 122.5.1 or if the design pressure of the downstream piping system and equipment is at least as high as the upstream design pressure.

122.5.3 Design of Valves and Pressure-Relieving Valves and Devices. Pressure-reducing and bypass valves, and pressure-relieving valves and devices, shall be designed for inlet pressure and temperature conditions. Pressure-relieving valves and devices shall be in accordance with the requirements of para. 107.8 of this Code.

122.6 Pressure Relief Piping

Pressure relief piping within the scope of this Code shall be supported to sustain reaction forces, and shall conform to the requirements of paras. 122.6.1 and 122.6.2.

⁵ For information on the prevention of water damage to steam turbines used for electric power generation, see ASME TDP-1.

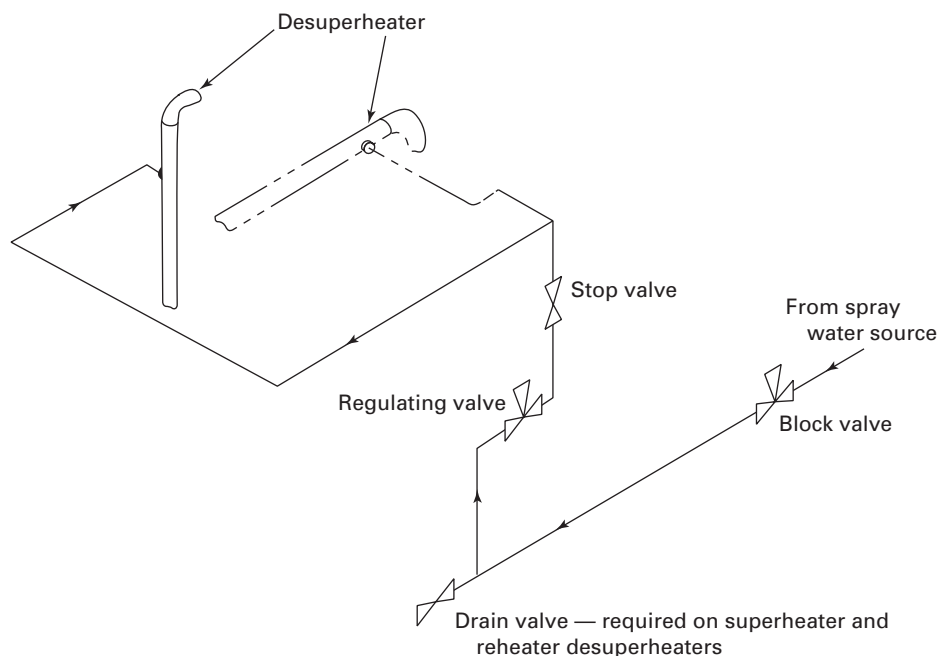
Fig. 122.4 Desuperheater Schematic Arrangement

GENERAL NOTE: This Figure is a schematic only and is not intended to show equipment layout or orientation.

122.6.1 Piping to Pressure-Relieving Valves and Devices

(A) There shall be no intervening stop valve(s) between piping being protected and the protective valve(s) or device(s).

(B) Diverter or changeover valves designed to allow servicing of redundant protective valves or devices without system depressurization may be installed between the piping to be protected and the required protective valves or devices under the following conditions:

(B.1) Diverter or changeover valves are prohibited on boiler external piping and reheat piping.

(B.2) One hundred percent (100%) of the required relieving capacity shall be continuously available any time the system is in service.

(B.3) Positive position indicators shall be provided on diverter or changeover valves.

(B.4) Positive locking mechanisms and seals shall be provided on diverter or changeover valves to preclude unauthorized or accidental operation.

(B.5) Diverter or changeover valves shall be designed for the most severe conditions of pressure, temperature, and loading to which they are exposed, and shall be in accordance with para. 107.

(B.6) Provision shall be made to safely bleed off the pressure between the isolated protective valve or device and the diverter or changeover valve.

122.6.2 Discharge Piping From Pressure-Relieving Valves and Devices

(A) There shall be no intervening stop valve between the protective valve(s) or device(s) and the point of discharge.

(B) When discharging directly to the atmosphere, discharge shall not impinge on other piping or equipment and shall be directed away from platforms and other areas used by personnel.

(C) It is recommended that individual discharge lines be used, but if two or more reliefs are combined, the discharge piping shall be designed with sufficient flow area to prevent blowout of steam or other fluids. Sectional areas of a discharge pipe shall not be less than the full area of the valve or device outlets discharging thereto, and the discharge pipe shall be as short and straight as possible and so arranged as to avoid undue stresses on the valve(s) or device(s).

(D) Discharge lines from pressure-relieving valves and devices within the scope of this Code shall be designed to facilitate drainage.

(E) When the umbrella or drip pan type of connection is used, the discharge piping shall be so designed as to prevent binding due to expansion movements.

(F) Drainage shall be provided to remove water collected above the seat of the pressure-relieving valve or device.

(G) Carbon steel materials listed in Mandatory Appendix A may be used for discharge piping that is subjected to temperatures above 800°F (427°C) only during operation of pressure-relieving valves [see para. 107.8.3(B)] provided that

(G.1) the duration of the pressure-relieving valve's operation is self-limiting

(G.2) the piping discharges directly to atmosphere

(G.3) the allowable stresses for carbon steel materials at temperatures above 800°F (427°C) shall be taken from Section II, Part D, Table 1A for materials applicable to Section I and Section VIII, Division 1 of the ASME Boiler and Pressure Vessel Code

122.7 Piping for Flammable or Combustible Liquids

122.7.1 General. Piping for flammable or combustible liquids including fuel and lubricating oils is within the scope of this Code. Piping for synthetic lubricants having no flash or fire point need not meet the requirements of para. 122.7.

The designer is cautioned that, among other criteria, static electricity may be generated by the flowing fluid. Additionally, the designer is cautioned of the extreme chilling effect of a liquefied gas flashing to vapor during loss of pressure. This is a factor for determining the lowest expected service temperature relative to the possibility of brittle fracture of materials. Consideration shall also be given to the pressure rise that may occur as a cold fluid absorbs heat from the surroundings.

122.7.2 Materials

(A) Seamless steel or nickel alloy piping materials shall be used in all areas where the line is within 25 ft (7.6 m) of equipment or other lines having an open flame or exposed parts with an operating temperature above 400°F (204°C). Seamless steel or nickel alloy pipe shall also be used for fuel oil systems located downstream of burner shutoff valve(s). The burner shutoff valve(s) shall be located as close to the burner as is practical.

(B) In all other areas, piping systems may include pipe or tube of steel, nickel alloy, copper, or brass construction. Copper tubing shall have a thickness not less than that required by para. 104.1.2(C.3), regardless of pressure. Refer also to paras. 105, 124.6, and 124.7(A).

Wherever materials other than steel or nickel alloy are used, they shall be so located that any spill resulting from the failure of these materials will not unduly expose persons, buildings, or structures, or can be readily controlled by remote valves.

(C) For lubricating oil systems, steel tubing is an acceptable alternative to steel pipe.

(D) Polyethylene (PE) and reinforced thermosetting resin (RTR) pipe may be used for flammable or combustible liquids, in buried installations only, in accordance with Mandatory Appendix N.

122.7.3 Piping Joints

(A) Welded joints shall be used between steel or nickel alloy piping components where practicable. Where bolted flanged joints are necessary, the gasket material shall be suitable for the service. Where threaded joints and compression fittings are unavoidable, the following requirements shall be met:

(A.1) For threaded joints, the pipe thickness shall be not less than Extra Strong regardless of pressure or type of material.

(A.2) The requirements of para. 114 shall apply to all threaded joints.

(A.3) Threaded joints and compression fittings shall be assembled carefully to ensure leak tightness. Threaded joints shall meet the requirements of para. 135.5. Compression fittings shall meet the requirements of paras. 115 and 135.6. A thread sealant, suitable for the service, shall be used in threaded joints unless the joint is to be seal welded or a gasket or O-ring is used to provide sealing at a surface other than the threads.

(B) Threaded joints in copper or brass pipe shall be subject to the same limitations as for steel pipe in (A.1), (A.2), and (A.3), above.

(C) Copper tubing shall be assembled with flared, flareless, or compression type joints as prescribed in para. 115, or brazed in accordance with para. 117. Soft solder type joints are prohibited.

(D) RTR pipe shall be adhesive bonded in accordance with the pipe manufacturer's recommended procedures.

(E) Pipe joints dependent on the friction characteristics or resiliency of combustible materials for mechanical or leak tightness of piping shall not be used inside buildings.

(F) Steel tubing shall be assembled with fittings in accordance with para. 115, or with socket weld fittings.

122.7.4 Valves and Specialties. Valves, strainers, meters, and other specialties shall be of steel or nickel alloy construction. As an alternative, ductile or malleable iron or copper alloy valves and specialties may be used, subject to the restrictions in paras. 124.6 and 124.7, where metal temperatures do not exceed 400°F (204°C).

122.8 Piping for Flammable Gases, Toxic Fluids (Gases or Liquids), or Nonflammable Nontoxic Gases

(A) Although some gases are liquefied for storage or transport, they shall be considered as gases if their Reid vapor pressure is greater than 40 psia [2 068.6 mm Hg (absolute)] at 100°F (37.8°C).

(B) Threaded joints and compression fittings may be used subject to the limitations of para. 114.2.1(B) and other specific limitations identified below, except they are permitted at connections to refillable storage containers and associated pressure regulators, shutoff valves, pumps, and meters, to a maximum pressure of 5,000 psig

[34 475 kPa (gage)], provided the size does not exceed NPS $\frac{3}{4}$ (DN 20).

122.8.1 Flammable Gas

(A) Some of the common flammable gases are acetylene, ethane, ethylene, hydrogen, methane, propane, butane, and natural or manufactured gas used for fuel. It shall be the designers' responsibility to determine the limiting concentrations (upper and lower explosive limits) and the properties of the gas under consideration. The use of explosive concentrations shall be avoided, or the piping shall be designed to withstand explosive forces.

Vent lines shall be routed in such a way as to avoid explosive concentrations while venting. Each flammable gas vent point shall be subjected to a hazard analysis that requires owner approval. The hazard analysis shall address

- (A.1) dissipation of the flammable gases
- (A.2) avoiding explosive concentrations
- (A.3) mitigating possible ignition sources by stopping hot work and other means
- (A.4) impingement of gases on nearby objects
- (A.5) foreign objects propelled by venting
- (A.6) chilling effect from the venting operation
- (A.7) protection of people by evacuation, by use of appropriate personal protective equipment, or by other means

The chilling effect from venting is a factor for determining the lowest expected service temperature relative to the possibility of brittle fracture of materials.

(B) *Materials.* Steel piping, subject to the limitations in para. 105, shall be used for all flammable gases, except as otherwise permitted in (B.2), (B.3), and (B.4) below.

(B.1) Welded joints shall be used between steel components where practicable. Where bolted flanged joints are necessary, the gasket material shall be suitable for the service. Where threaded joints and compression fittings are unavoidable, the following requirements shall be met:

(B.1.1) For threaded joints, the pipe thickness shall be not less than Extra Strong regardless of pressure or type of material.

(B.1.2) Threaded joints and compression fittings may be used subject to the limitations of para. 122.8(B).

(B.1.3) Threaded joints and compression fittings shall be assembled carefully to ensure leak tightness. Threaded joints shall meet the requirements of para. 135.5. Compression fittings shall meet the requirements of paras. 115 and 135.6. A thread sealant, suitable for the service, shall be used in threaded joints unless the joint is to be seal welded or a gasket or O-ring is used to provide sealing at a surface other than the threads.

(B.2) For hydrogen systems, the following alternative materials may be used:

- (B.2.1) seamless steel tubing with welded joints.

(B.2.2) seamless copper or brass pipe or tubing with brazed, threaded, or compression fitting joints. Threaded fittings shall not exceed NPS $\frac{3}{4}$ (DN 20). For protection against damage, tubing shall be installed in a guarded manner that will prevent damage during construction, operation, or service. Valves with suitable packing, gages, regulators, and other equipment may also consist of copper alloy materials. Safety relief devices shall be vented individually, and connected vent piping shall be designed to convey the fluid, without pockets, to the outside atmosphere; and then directed away from equipment ventilation systems, and vents from other systems.

(B.3) For fuel gas instrumentation and control, seamless copper tubing subject to the following restrictions may be used:

(B.3.1) The design pressure shall not exceed 100 psi (690 kPa).

(B.3.2) Tubing shall not exceed $\frac{5}{8}$ in. (15.9 mm) nominal outside diameter.

(B.3.3) All joints shall be made with compression or flared fittings.

(B.3.4) Copper tubing shall not be used if the fuel gas contains more than 0.3 grains (19.4 mg) of hydrogen sulfide per 100 ft³/min (47 liters/sec) of gas at standard conditions.

(B.3.5) Consideration shall be given in the design to the lower strength and melting point of copper compared to steel. Adequate support and protection from high ambient temperatures and vibration shall be provided.

(B.3.6) Tubing shall be installed in a guarded manner that will prevent damage during construction, operation, and service.

(B.4) Polyethylene (PE) pipe may be used for natural gas service, in buried installations only, in accordance with Mandatory Appendix N.

(C) *Valves and Specialties.* Valves, strainers, meters, and other specialties shall be of steel or nickel alloy construction. As an alternative, ductile iron or copper alloy valves and specialties may be used, subject to the restrictions in paras. 124.6 and 124.7, where metal temperatures do not exceed 400°F (204°C).

(D) For in-plant fuel gas distribution system(s) where the use of a full-relieving-capacity safety or safety-relief valve(s) as described in para. 107.8.3(B) could create an undue venting hazard, an alternative pressure limiting design may be substituted. The alternative design shall include all provisions below.

(D.1) *Tandem Gas Pressure Reducing Valves.* To protect the low pressure system, two gas pressure reducing valves capable of independent operation shall be installed in series. Each shall have the capability of closing off against the maximum upstream pressure, and of controlling the pressure on the low pressure side at or below the design pressure of the low pressure system,

in the event that the other valve fails open. Control lines must be suitably protected, designed, and installed so that damage to any one control line will not result in over pressurizing the downstream piping.

(D.2) *Trip Stop Valve.* A fail-safe trip stop valve shall be installed to automatically close, in less than 1 sec, at or below the design pressure of the downstream piping. It shall be a manually reset design. The pressure switch for initiating closure of the trip stop valve shall be hard-wired directly to the valve tripping circuit. The pressure switch shall be mounted directly on the low pressure piping without an intervening isolation valve. The trip stop valve shall be located so that it is accessible and protected from mechanical damage and from weather or other ambient conditions that could impair its proper functioning. It may be located upstream or downstream of the tandem gas pressure reducing valves. The trip stop valve and all upstream piping shall be designed for the maximum upstream supply pressure. The trip stop valve may also serve as the upstream isolation valve of a double-block and vent gas supply isolation system. Provision shall be made to safely bleed off the pressure downstream of the trip stop valve.

(D.3) *Safety Pressure Relief.* The low pressure system shall be protected from any leakage through the pressure-reducing valves, when closed, by a safety-relief valve constructed and designed in accordance with para. 107.8.3(B), and sized for the possible leakage rate.

122.8.2 Toxic Fluids (Gas or Liquid)

(A) For the purpose of this Code, a toxic fluid is one that may be lethal, or capable of producing injury and/or serious illness through contact, inhalation, ingestion, or absorption through any body surface. It shall be the designers' responsibility to adopt the safety precautions published by the relevant fluid industry which may be more stringent than those described in this Code for toxic fluids. In addition, the piping shall be installed in such a manner that will minimize the possibility of damage from external sources.

(B) Preferably, pipe and pipe fittings should be seamless steel. Wall thickness shall not be less than that in Table 122.8.2(B).

If the fluid is known to be corrosive to the steels in Table 122.8.2(B), the materials and wall thickness selected shall be suitable for the service. (Refer to para. 104.1.2.)

(C) Welded joints shall be used between steel components where practicable. Backing rings used for making girth butt welds shall be removed after welding. Miter welds are prohibited. Fabricated branch connections (shaped branch pipe welded directly to run pipe) may be used only if other types of branch connections permitted by para. 104.3.1 are not available. Socket welded joints shall be used only with steel materials and shall not be larger than NPS 2½ (DN 65). Where bolted flanged joints are necessary, socket weld or welding neck flanges

Table 122.8.2(B) Minimum Wall Thickness Requirements for Toxic Fluid Piping

Size	Carbon and Low Alloy Steel (Mandatory Appendix A, Tables A-1 and A-2)	Stainless and Nickel Alloy Steel (Mandatory Appendix A, Tables A-3 and A-4)
NPS 2 (DN 50) and smaller	Extra strong	Schedule 10S
Larger than NPS 2 (DN 50)	Standard weight	Schedule 5S

shall be used. Gasket materials shall be suitable for the service. Compression fittings are prohibited. Where the use of threaded joints is unavoidable, all of the following requirements shall be met:

(C.1) The pipe thickness shall be not less than Extra Strong, regardless of pressure or type of material.

(C.2) In addition to the provisions of para. 122.8(B), threaded joints and compression fittings may be used at connections to refillable storage containers and associated pressure regulators, shutoff valves, pumps, and meters to a maximum pressure of 50 psig [345 kPa (gage)], provided the size does not exceed NPS 2 (DN 50).

(C.3) Threaded joints shall be assembled carefully to ensure leak tightness. The requirements of para. 135.5 shall be met. A thread sealant, suitable for the service, shall be used unless the joint is to be seal welded or a gasket or O-ring is used to provide sealing at a surface other than the threads.

(D) Steel valves shall be used. Bonnet joints with tapered threads are not permitted. Special consideration shall be given to valve design to prevent stem leakage to the environment. Bonnet or cover plate closures and other body joints shall be one of the following types:

(D.1) union

(D.2) flanged with suitable gasketing and secured by at least four bolts

(D.3) proprietary, attached by bolts, lugs, or other substantial means, and having a design that increases gasket compression as fluid pressure increases

(D.4) threaded with straight threads sufficient for mechanical strength, metal-to-metal seats, and a seal weld made in accordance with para. 127.4.5, all acting in series

(E) Tubing not larger than 5/8 in. (16 mm) O.D. with socket welding fittings may be used to connect instruments to the process line. An accessible root valve shall be provided at the process lines to permit isolating the tubing from the process piping. The layout and mounting of tubing shall minimize vibration and exposure to possible damage.

(F) The provisions of para. 102.2.4 are not permitted. The simplified rules for analysis in para. 119.7.1 (A.3) are not permitted. The piping system shall be designed to minimize impact and shock loads. Suitable dynamic analysis shall be made where necessary to avoid or minimize vibration, pulsation, or resonance effects in the piping. The designer is cautioned to consider the possibility of brittle fracture of the steel material selected over the entire range of temperatures to which it may be subjected.

(G) For dry chlorine service between -20°F (-29°C) and 300°F (149°C), the pipe material shall not be less in thickness than seamless Extra Strong steel.

(H) Toxic fluid piping shall be pneumatic leak tested in accordance with para. 137.5. Alternatively, mass spectrometer or halide leak testing in accordance with para. 137.6, and a hydrostatic test in accordance with para. 137.3 may be performed.

(I) Where it is not possible to avoid venting toxic gases (such as discharges from safety relief devices where containment is impractical), vent lines shall be routed in such a way as to avoid exposing personnel to hazardous concentrations while venting. Each toxic gas vent point shall be subjected to a hazard analysis that requires owner approval. The hazard analysis shall address the following:

(I.1) dissipation of the toxic gases

(I.2) avoiding exposing personnel to toxic concentrations by vent point location, by evacuation, by use of appropriate personal protective equipment, or by other means

(I.3) foreign objects propelled by venting

(I.4) chilling effect from the venting operation [see para. 122.8.1(A)]

122.8.3 Nonflammable Nontoxic Gas

(A) Piping for nonflammable and nontoxic gases, such as air, oxygen, carbon dioxide, and nitrogen, shall comply with the requirements of this Code, except as otherwise permitted in (B) below. The designer is cautioned of the extreme chilling effect during rapid expansion. This is a factor for determining the lowest expected service temperature relative to the brittle fracture of the material selected.

(B) Threaded joints and compression fittings may be used subject to the conditions of para. 122.8(B).

122.9 Piping for Corrosive Liquids and Gases

Where it is necessary to use special material, such as glass, plastics, or metallic piping lined with nonmetals, not listed in Table 126.1, for conveying corrosive or hazardous liquids and gases, the design shall meet the requirements of para. 104.7.

122.10 Temporary Piping Systems

Prior to test and operation of the power plant and its included piping systems, most power and auxiliary

service piping are subjected to flushing or chemical cleaning to remove internal foreign material such as rust particles, scale, welding or brazing residue, dirt, etc., which may have accumulated within the piping during the construction period. This Code does not address the flushing or cleaning operations. Temporary piping, that is piping attached to the permanent piping system whose function is to provide means for introducing and removing the fluids used in the flushing or cleaning operations, shall be designed and constructed to withstand the operating conditions during flushing and cleaning. The following minimum requirements shall apply to temporary piping systems:

(A) Each such system shall be analyzed for compliance with para. 103.

(B) Connections for temporary piping to the permanent piping systems that are intended to remain, shall meet the design and construction requirements of the permanent system to which they are attached.

(C) The temporary systems shall be supported such that forces and moments due to static, dynamic and expansion loadings will not be transferred in an unacceptable manner to the connected permanent piping system. Paragraphs 120 and 121 shall be used as guidance for the design of the temporary piping systems supporting elements.

(D) The temporary systems shall be capable of withstanding the cyclic loadings that occur during the flushing and cleaning operations. Particular attention shall be given to the effects of large thrust forces that may be generated during high velocity blowing cycles. Where steam piping is to be subjected to high velocity blowing operations, continuous or automatic draining of trapped or potentially trapped water within the system shall be incorporated. Supports at the exhaust terminals of blowdown piping shall provide for restraint of potential pipe whip.

(E) Where necessary, temporary systems containing cast iron or carbon steel material subject to chemical cleaning shall be prewarmed to avoid the potential for brittle failure of the material.

(F) Where temporary piping has been installed and it does not comply with the requirements of this Code for permanent piping systems, it shall be physically removed or separated from the permanent piping to which it is attached prior to testing of the permanent piping system and prior to plant startup.

122.11 Steam Trap Piping

122.11.1 Drip Lines. Drip lines from piping or equipment operating at different pressures shall not be connected to discharge through the same trap.

122.11.2 Discharge Piping. Trap discharge piping shall be designed to the same pressure as the inlet piping unless the discharge is vented to atmosphere, or is operated under low pressure and has no stop valves. In no

case shall the design pressure of trap discharge piping be less than the maximum discharge pressure to which it may be subjected. Where two or more traps discharge into the same header, a stop valve shall be provided in the discharge line from each trap. Where the pressure in the discharge piping can exceed the pressure in the inlet piping, a check valve shall be provided in the trap discharge line. A check valve is not required if either the stop valve or the steam trap is designed to automatically prevent reverse flow and is capable of withstanding a reverse differential pressure equal to the design pressure of the discharge piping.

122.12 Exhaust and Pump Suction Piping

Exhaust and pump suction lines for any service and pressure shall have pressure-relieving valves or devices of suitable size unless the lines and attached equipment are designed for the maximum pressure to which they may accidentally or otherwise be subjected, or unless a suitable alarm indicator, such as a whistle or free blowing pressure-relieving valve, is installed where it will warn the operator.

122.13 Pump Discharge Piping

Pump discharge piping from the pump up to and including the valve normally used for isolation or flow control shall be designed for the maximum sustained pressure exerted by the pump and for the highest coincident fluid temperature, as a minimum. Variations in pressure and temperature due to occasional inadvertent operation are permitted as limited in para. 102.2.4 under any of the following conditions:

(A) during operation of overpressure relieving valves designed to protect the piping system and the attached equipment

(B) during a short period of abnormal operation, such as pump overspeed

(C) during uncontrolled transients of pressure or temperature

122.14 District Heating and Steam Distribution Systems

122.14.1 General. Where pressure-reducing valves are used, one or more pressure-relieving valves or devices shall be provided on the low pressure side of the system. Otherwise, the piping and equipment on the low pressure side of the system shall be designed to withstand the upstream design pressure. The pressure-relieving valve(s) or device(s) shall be located adjoining or as close as practicable to the reducing valve. The combined relieving capacity provided shall be such that the design pressure of the low pressure system will not be exceeded if the reducing valve fails open.

122.14.2 Alternative Systems. In district heating and steam distribution systems where the steam pressure does not exceed 400 psi (2 750 kPa) and where the use of pressure-relieving valves or devices as described in para. 122.14.1 is not feasible (e.g., because there is no acceptable discharge location for the vent piping), alternative designs may be substituted for the relief valve(s) or device(s). In either case, it is recommended that alarms be provided that will reliably warn the operator of failure of any pressure-reducing valve.

(A) *Tandem Steam Pressure Reducing Valves.* Two or more steam pressure reducing valves capable of independent operation may be installed in series, each set at or below the safe working pressure of the equipment and piping system served. In this case, no relief valve or device is required.

Each pressure-reducing valve shall have the capability of closing off against full line pressure, and of controlling the reduced pressure at or below the design pressure of the low pressure system, in the event that the other valve fails open.

(B) *Trip Stop Valves.* A trip stop steam valve set to close at or below the design pressure of the low pressure system may be used in place of a second reducing valve or a relief valve.

Chapter III Materials

123 GENERAL REQUIREMENTS

Chapter III contains limitations and required qualifications for materials based on their inherent properties. Use of these materials in piping systems is also subject to requirements and limitations in other parts of this Code.

123.1 Materials and Specifications

123.1.1 Listed Materials. Material meeting the following requirements shall be considered listed and acceptable material:

(A) Materials for which allowable stress values are listed in Mandatory Appendix A or that have been approved by the procedure established by (C) below.

(B) A material conforming to a specification for which allowable stresses are not listed in Mandatory Appendix A is acceptable provided its use is not specifically prohibited by this Code Section and it satisfies one of the following requirements:

(B.1) It is referenced in a standard listed in Table 126.1. Such a material shall be used only within the scope of and in the product form covered by the referencing standard listed in Table 126.1.

(B.2) It is referenced in other parts of this Code Section and shall be used only within the scope of and in the product form permitted by the referencing text.

(C) Where it is desired to use materials that are not currently acceptable under the rules of this Code Section, written application shall be made to the Committee fully describing the proposed material and the contemplated use. Such material shall not be considered listed and not used as a listed material until it has been approved by the Committee and allowable stress values have been assigned. Details of information that should be included in such applications are given in Nonmandatory Appendix VI. See para. 123.1.2.

(D) Materials conforming to ASME SA or SB specifications may be used interchangeably with material specified to the listed ASTM A or B specifications of the same number, except where the requirements of para. 123.2.2 apply.

(E) The tabulated stress values in Mandatory Appendix A that are shown in italics are at temperatures in the range where creep and stress rupture strength govern the selection of stresses.

123.1.2 Unlisted Materials. Materials other than those meeting the requirements of para. 123.1.1 shall be

considered unlisted materials. Such unlisted materials may only be used for nonboiler external piping provided they satisfy all of the following requirements:

(A) Unlisted materials are certified by the material manufacturer to satisfy the requirements of a specification listed in any Code Section of the ASME B31 Code for Pressure Piping, the ASME Boiler and Pressure Vessel Code, Section II, Part D, or to a published specification covering chemistry, physical and mechanical properties, method and process of manufacture, heat treatment, and quality control.

(B) The allowable stresses of the unlisted materials shall be determined in accordance with the rules of para. 102.3.1(C).

(C) Unlisted materials shall be qualified for service within a stated range of minimum and maximum temperatures based upon data associated with successful experience, tests, or analysis; or a combination thereof. See para. 124.1.2 for minimum service temperature qualifications.

(D) The designer shall document the owner's acceptance for use of unlisted material.

(E) All other requirements of this Code are satisfied.

123.1.3 Unknown Materials. Materials of unknown specification shall not be used for pressure-containing piping components.

123.1.5 Size or Thickness. Materials outside the limits of size or thickness given in the title or scope clause of any specification listed in Table 126.1 may be used if the material is in compliance with the other requirements of the specification, and no other similar limitation is given in the rules for construction.

123.1.6 Marking of Materials or Products. Materials or products marked as meeting the requirements for more than one grade, type, or alloy of a material specification or multiple specifications, are acceptable provided

(A) one of the markings includes the material specification, grade, class, and type or alloy of the material permitted by this Code and the material meets all the requirements of that specification

(B) the appropriate allowable stress for the specified grade, type, or alloy of a material specification from Mandatory Appendix A is used

(C) all other requirements of this Code are satisfied for the material permitted

123.1.7 Materials Manufactured to Other Specification Editions. Materials may meet the requirements of material specification editions other than the editions listed in Mandatory Appendix F provided

(A) the materials are the same specification, grade, type, class, or alloy, and heat-treated condition, as applicable.

(B) the material tensile and yield strengths shall be compared and any differences shall be evaluated. If the material has a lower strength than required by the edition of the specification in Mandatory Appendix F, the effect of the reduction on the allowable stress and the design shall be reconciled.

123.2 Piping Components

123.2.1 General. Materials that do not comply with the rules of para. 123.1 may be used for flared, flareless, and compression type tubing fittings, provided that the requirements of para. 115 are met.

123.2.2 Boiler External Piping

(A) Materials for boiler external piping, as defined in para. 100.1.2(A), shall be specified in accordance with ASME SA, SB, or SFA specifications. Material produced under an ASTM specification may be used, provided that the requirements of the ASTM specification are identical or more stringent than the ASME specification for the Grade, Class, or Type produced. The material manufacturer or component manufacturer shall certify, with evidence acceptable to the Authorized Inspector, that the ASME specification requirements have been met. Materials produced to ASME or ASTM material specifications are not limited as to country of origin.

(B) Materials that are not fully identified shall comply with PG-10 of Section I of the ASME Boiler and Pressure Vessel Code.

(C) In addition to materials listed in Mandatory Appendix A without Note (1), materials that are listed in Section I of the ASME Boiler and Pressure Vessel Code may be used in boiler external piping. When such Section I materials are used, the allowable stresses shall be those listed in Section II, Part D, Subpart 1, Tables 1A and 1B applicable to Section I. For these Section I materials, the applicable requirements in Table 1A, Table 1B, and Section I paras. PG-5 through PG-13, PW-5, PWT-5, PMB-5, and PEB-5 shall be met.

123.3 Pipe-Supporting Elements

Materials used for pipe-supporting elements shall be suitable for the service and shall comply with the requirements of para. 121.2(C), para. 121.7.2(C), para. 121.7.2(D), para. 123.1, or MSS SP-58. When utilizing MSS SP-58, the allowable stresses for unlisted materials shall be established in accordance with the rules of para. 102.3.1(C) of ASME B31.1 in lieu of para. 4.4 of MSS SP-58.

123.4 Longitudinal-Welded or Spiral-Welded Pipe With Filler Metal Added

(A) For the purposes of para. 104.1.1, the start of the creep range is the highest temperature where the non-italicized stress values end in Mandatory Appendix A.

(B) All welds in longitudinal-welded or spiral-welded pipe operating in the creep range shall receive and pass a 100% volumetric examination (RT or UT) per the applicable material specification or in accordance with para. 136.4.5 or 136.4.6 and Table 136.4, or the joint efficiency factor (used as a multiplier to the weld strength reduction factor) from Table 102.4.7 shall be used.

124 LIMITATIONS ON MATERIALS

124.1 Temperature Limitations

124.1.1 Upper Temperature Limits. The materials listed in the Allowable Stress Tables A-1 through A-10, Mandatory Appendix A, shall not be used at design temperatures above those for which stress values are given except as permitted by para. 122.6.2(G).

124.1.2 Lower Temperature Limits

(A) The designer shall give consideration to the possibility of brittle fracture at low service temperature.

(B) The requirements of ASME B31T, Standard Toughness Requirements for Piping, shall be met.

(B.1) For materials listed in B31T, see Nonmandatory Appendix VIII for guidelines to determine if low-temperature service requirements apply.

(B.2) For materials not listed in B31T, the designer shall establish the T-number group using the guidelines provided in B31T Nonmandatory Appendix B, and the requirements of B31T for that T-number group shall be met. To confirm the T-number group assignment, impact tests shall be run on three heats of the material. The test shall be in accordance with the requirements of section 4 of B31T and the test temperature shall be at or below the "Material Minimum Temperature Without Impacts" listed for the T-number group in Table 3.1-1 of B31T.

124.2 Steel

(A) Upon prolonged exposure to temperatures above 800°F (427°C), the carbide phase of plain carbon steel, plain nickel alloy steel, carbon-manganese alloy steel, manganese-vanadium alloy steel, and carbon-silicon steel may be converted to graphite.

(B) Upon prolonged exposure to temperatures above 875°F (468°C), the carbide phase of alloy steels, such as carbon-molybdenum, manganese-molybdenum-vanadium, manganese-chromium-vanadium, and chromium-vanadium, may be converted to graphite.

(C) Carbon or alloy steel having carbon content of more than 0.35% shall not be used in welded construction or be shaped by oxygen cutting process or other thermal cutting processes.

(D) Where low alloy 2¼% chromium steels are used at temperatures above 850°F (454°C), the carbon content of the base material and weld filler metal shall be 0.05% or higher.

124.4 Cast Gray Iron

The low ductility of cast gray iron may result in sudden failure if shock loading (pressure, temperature, or mechanical) should occur. Possible shock loadings and consequences of failure must be considered before specifying the use of such material. Cast iron components may be used within the nonshock pressure–temperature ratings established by the standards and specifications herein and in para. 105.2.1(B). Castings to ASME SA-278 and ASTM A278 shall have maximum limits of 250 psig [1 725 kPa (gage)] and 450°F (232°C).

The following referenced paragraphs prohibit or restrict the use of gray cast iron for certain applications or to certain pressure–temperature ratings:

Pipe supports	121.7.2(C)
BEP blowoff	122.1.4(A.3)
BEP blowdown	122.1.4(B.3)
BEP valves and fittings	122.1.7
Blowoff valves	122.1.7(C.5) and (C.6)
Non-BEP blowoff	122.2(A.1)
Non-BEP blowdown	122.2(A.2)
Flammable or combustible liquids	122.7.2(A) and (B), 122.7.4
Flammable gases	122.8.1(B) and (C)
Toxic gases or liquids	122.8.2(B) and (D)

124.5 Malleable Iron

Certain types of malleable iron have low ductility characteristics and may be subject to brittle fracture. Malleable iron may be used for design conditions not to exceed 350 psig [2 415 kPa (gage)] or 450°F (232°C).

The following referenced paragraphs prohibit or restrict the use of malleable iron for certain applications or to certain pressure–temperature ratings:

Pipe supports	121.7.2(D)
BEP blowoff	122.1.4(A.3)
BEP blowdown	122.1.4(B.3)
Non-BEP blowoff	122.2(A.1)
Non-BEP blowdown	122.2(A.2)
Flammable or combustible liquids	122.7.2(A) and (B), 122.7.4
Flammable gases	122.8.1(B) and (C)
Toxic gases or liquids	122.8.2(B) and (D)

124.6 Ductile (Nodular) Iron

Ductile iron components complying with ANSI/AWWA C110/A21.10, C115/A21.15, C151/A21.51, or C153/A21.53 may be used for water and other nontoxic, nonflammable service, with pressure limits as specified in those standards and temperature limits as specified in para. 106(E). These components may not be used for boiler external piping.

Ductile (nodular) iron components conforming to ASME B16.42 may be used for services including boiler external piping under the following conditions:

(A) Components for boiler external piping shall be used only within the following limitations.

(A.1) Only ASME SA-395 material may be used.

(A.2) Design pressure shall not exceed 350 psig [2 415 kPa (gage)].

(A.3) Design temperature shall not exceed 450°F (232°C).

(B) Welding shall not be used, either in fabrication of the components or in their assembly as a part of a piping system.

(C) The following referenced paragraphs prohibit or restrict the use of ductile iron for certain applications or to certain pressure–temperature ratings:

BEP blowoff	122.1.4(A.3)
BEP blowdown	122.1.4(B.3)
BEP blowoff valves	122.1.7(C.5) and (C.6)
Non-BEP blowoff	122.2(A.1)
Non-BEP blowdown	122.2(A.2)
Flammable or combustible liquids	122.7.2(A) and (B), 122.7.4
Flammable gases	122.8.1(B) and (C)
Toxic gases or liquids	122.8.2(B) and (D)
Pipe supports	123.3

124.7 Nonferrous Metals

Nonferrous metals may be used in piping systems under the following conditions:

(A) The melting points of copper, copper alloys, aluminum, and aluminum alloys must be considered particularly where there is a fire hazard.

(B) The Designer shall consider the possibility of galvanic corrosion when combinations of dissimilar metals, such as copper, aluminum, and their alloys, are used in conjunction with each other or with steel or other metals in the presence of an electrolyte.

(C) *Threaded Connections.* A suitable thread compound shall be used in making up threaded joints in aluminum pipe to prevent seizing that might cause leakage and perhaps prevent disassembly. Pipe in the annealed temper should not be threaded.

124.8 Cladding and Lining Materials

Materials with cladding or lining may be used provided that

(A) the base material is an approved Code material. The allowable stress used shall be that of the base metal at the design temperature.

(B) the cladding or lining is a material that in the judgment of the user is suitable for the intended service, and the cladding/lining and its method of application do not detract from the serviceability of the base material.

(C) bending procedures are such that damaging or detrimental thinning of the cladding material is prevented.

(D) welding and the inspection of welds is in accordance with the provisions of Chapters V and VI of this Code.

(E) the thickness of the cladding is not credited for structural strength in the piping design.

124.9 Nonmetallic Pipe

This Code recognizes the existence of a wide variety of nonmetallic piping materials that may be used in corrosive (either internal or external) or other specialized applications. Extreme care must be taken in their selection, as their design properties vary greatly and depend upon the material, type, and grade. Particular consideration shall be given to

- (A) possible destruction where fire hazard is involved
- (B) possible decrease in tensile strength at slight increase in temperature
- (C) effects of toxicity
- (D) requirements for providing adequate support for flexible pipe

Rules and service limitations for plastic and elastomer-based piping materials, including thermoplastics and reinforced thermosetting resins, are given in Mandatory Appendix N.

124.10 Deterioration of Materials in Service

It is the responsibility of the engineer to select materials suitable for the intended application. Some guideline for selection of protective coatings for metallic piping are provided in Nonmandatory Appendix IV.

124.11 Gaskets

Limitations on gasket materials are covered in para. 108.4.

124.12 Bolting

Limitations on bolting materials are covered in para. 108.5.

125 CREEP STRENGTH ENHANCED FERRITIC MATERIALS

125.1 Requirements for ASTM A217 Grade C12A Castings

125.1.1 Required Examinations. The casting shall be examined in accordance with the requirements of para. 102.4.6(B).

Alternatively, castings for valves may be examined in accordance with the requirements of ASME B16.34 for special class valves.

125.1.2 Heat Treatment Requirements

(A) The material shall be austenitized within the temperature range of 1,900°F to 1,975°F (1 040°C to 1 080°C),

followed by air or accelerated cooling¹ to a temperature of 200°F (95°C) or below, followed by tempering within a range of 1,350°F to 1,470°F (730°C to 800°C). However, if a major weld repair, as defined in ASTM A217, Section 9.4, is made after the austenitizing and tempering heat treatment, then a new austenitizing and tempering heat treatment in accordance with the requirements of this subparagraph shall be carried out.

(B) When heat treating single castings, compliance with the specified temperature range shall be verified by thermocouples placed directly on the casting. For castings that are heat treated in batches, compliance with the specified temperature range shall be verified by thermocouples placed on selected castings in each heat treatment batch. The number and location of thermocouples to be placed on each casting, or on each heat treatment batch of castings, for verification of heat treatment shall be as agreed between the purchaser and the producer. A record of the final austenitizing and tempering heat treatment, and any subsequent subcritical heat treatment, to include both the number and location of thermocouples applied to each casting, or to each heat treatment batch of castings, shall be prepared and made available to the purchaser. In addition, all heat treatment temperatures and cycle times for the final austenitizing and tempering heat treatment, and any subsequent subcritical heat treatment, shall be shown on the certification report.

(C) The hardness of the cast material after the final heat treatment (including PWHT) shall be Brinell hardness number 185 to 248 or Rockwell B90 to C25. Hardness testing shall be in accordance with Supplementary Requirement S13 of ASTM A217.

125.1.3 Weld Repair Requirements

(A) Weld repairs to castings shall be made with one of the following welding processes and consumables:

- (A.1) SMAW, SFA-5.5/SFA-5.5M E90XX-B9
- (A.2) SAW, SFA-5.23/SFA-5.23M EB9 + neutral flux
- (A.3) GTAW, SFA-5.28/SFA-5.28M ER90S-B9
- (A.4) FCAW, SFA-5.29/SFA-5.29M E91T1-B9

In addition, the Ni + Mn content of all welding consumables shall not exceed 1.0%.

(B) Weld repairs to castings as part of material manufacture shall be made with welding procedures and welders qualified in accordance with ASME BPVC Section IX.

(C) All weld repairs shall be recorded with respect to their location on the casting. For all major weld repairs, as defined in ASTM A217, Section 9.4, the record shall include a description of the length, width, and depth of the repair. Supplementary Requirement S12 of ASTM A703 shall apply. For weld repairs performed as part of material manufacture, the documentation shall

¹ To facilitate complete transformation to martensite after the austenitizing, cooling should be as uniform as possible.

be included with the Material Test Report. For weld repairs performed on components for boiler external piping by the Manufacturer, documentation shall be included with the Manufacturer's Data Report.

125.1.4 Overheating Requirements. If, during the manufacturing, any portion of the component is heated to a temperature greater than 1,470°F (800°C), then the component shall be re-austenitized and retempered in

its entirety in accordance with para. 125.1.2, or that portion of the component heated above 1,470°F (800°C), including the heat-affected zone created by the local heating, shall be replaced or shall be removed, re-austenitized, retempered, and then replaced in the component.

125.1.5 Certification Requirements. A manufacturer's test report meeting certification requirements of ASTM A703 shall be provided.

Chapter IV

Dimensional Requirements

126 MATERIAL SPECIFICATIONS AND STANDARDS FOR STANDARD AND NONSTANDARD PIPING COMPONENTS

126.1 Standard Piping Components

Dimensions of standard piping components shall comply with the standards and specifications listed in Table 126.1 in accordance with para. 100.

126.2 Nonstandard Piping Components

When nonstandard piping components are designed in accordance with para. 104, adherence to dimensional standards of ANSI and ASME is strongly recommended when practicable.

126.3 Referenced Documents

The documents listed in Table 126.1 may contain references to codes, standards, or specifications not listed in this Table. Such unlisted codes, standards, or specifications are to be used only in the context of the listed documents in which they appear.

Where documents listed in Table 126.1 contain design rules that are in conflict with this Code, the design rules of this Code shall govern.

The fabrication, assembly, examination, inspection, and testing requirements of Chapters V and VI apply to the construction of piping systems. These requirements are not applicable to piping components manufactured in accordance with the documents listed in Table 126.1 unless specifically so stated.

(16)

Table 126.1 Specifications and Standards

Designator	Title
AISC Publication	
...	Manual of Steel Construction Allowable Stress Design
ASCE Standard	
ASCE/SEI 7	Minimum Design Loads for Buildings and Other Structures
ASTM Ferrous Material Specifications	
Bolts, Nuts, and Studs	
A193/A193M	Alloy-Steel and Stainless Steel Bolting Materials for High-Temperature Service
A194/A194M	Carbon and Alloy Steel Nuts for Bolts for High-Pressure and High-Temperature Service
A307	Carbon Steel Bolts and Studs, 60,000 psi Tensile Strength
A320/A320M	Alloy-Steel Bolting Materials for Low-Temperature Service
A354	Quenched and Tempered Alloy Steel Bolts, Studs and Other Externally-Threaded Fasteners
A437/A437M	Stainless and Alloy-Steel Turbine-Type Bolting Material Specially Heat Treated for High Temperature Service
A449	Hex Cap Screws, Bolts, and Studs, Steel, Heat Treated
A453 / A453M	High-Temperature Bolting Materials, With Expansion Coefficients Comparable to Austenitic Steels
Castings	
A47/A47M	Ferritic Malleable Iron Castings
A48/A48M	Gray Iron Castings
A126	Gray Iron Castings for Valves, Flanges, and Pipe Fittings
A197/A197M	Cupola Malleable Iron
A216/A216M	Steel Castings, Carbon Suitable for Fusion Welding for High Temperature Service
A217/A217M	Steel Castings, Martensitic Stainless and Alloy, for Pressure-Containing Parts Suitable for High-Temperature Service
A278/A278M	Gray Iron Castings for Pressure-Containing Parts for Temperatures Up to 650°F (350°C)
A351/A351M	Steel Castings, Austenitic, for High-Temperature Service
A389/A389M	Steel Castings, Alloy, Specially Heat-Treated for Pressure-Containing Parts Suitable for High-Temperature Service
A395/A395M	Ferritic Ductile Iron Pressure-Retaining Castings for Use at Elevated Temperatures
A536	Ductile Iron Castings
Forgings	
A105/A105M	Carbon Steel Forgings for Piping Applications
A181/A181M	Carbon Steel Forgings for General Purpose Piping
A182/A182M	Forged or Rolled Alloy and Stainless Steel Pipe Flanges, Forged Fittings, and Valves and Parts for High-Temperature Service
A336/A336M	Alloy Steel Forgings for Pressure and High-Temperature Parts
A350/A350M	Carbon and Low-Alloy Steel Forgings Requiring Notch Toughness Testing for Piping
A965/A965M	Steel Forgings, Austenitic, for Pressure and High Temperature Parts
Cast Pipe	
A377	Standard Index of Specifications for Ductile Iron Pressure Pipe
A426/A426M	Centrifugally Cast Ferritic Alloy Steel Pipe for High-Temperature Service
A451/A451M	Centrifugally Cast Austenitic Steel Pipe for High-Temperature Service
Seamless Pipe and Tube	
A106/A106M	Seamless Carbon Steel Pipe for High-Temperature Service
A179/A179M	Seamless Cold-Drawn Low-Carbon Steel Heat-Exchanger and Condenser Tubes
A192/A192M	Seamless Carbon Steel Boiler Tubes for High-Pressure Service
A210/A210M	Seamless Medium-Carbon Steel Boiler and Superheater Tubes
A213/A213M	Seamless Ferritic and Austenitic Alloy-Steel Boiler, Superheater, and Heat-Exchanger Tubes
A335/A335M	Seamless Ferritic Alloy Steel Pipe for High-Temperature Service
A369/A369M	Carbon and Ferritic Alloy Steel Forged and Bored Pipe for High-Temperature Service
A376/A376M	Seamless Austenitic Steel Pipe for High-Temperature Central-Station Service

Table 126.1 Specifications and Standards (Cont'd)

Designator	Title
ASTM Ferrous Material Specifications (Cont'd)	
Seamless and Welded Pipe and Tube	
A53/A53M	Pipe, Steel, Black and Hot-Dipped, Zinc-Coated Welded and Seamless
A268/A268M	Seamless and Welded Ferritic and Martensitic Stainless Steel Tubing for General Service
A312/A312M	Seamless and Welded and Heavily Cold Worked Austenitic Stainless Steel Pipe
A333/A333M	Seamless and Welded Steel Pipe for Low-Temperature Service
A450/A450M	General Requirements for Carbon and Low Alloy Steel Tubes
A530/A530M	General Requirements for Specialized Carbon and Alloy Steel Pipe
A714	High-Strength Low-Alloy Welded and Seamless Steel Pipe
A789/A789M	Standard Specification for Seamless and Welded Ferritic/Austenitic Stainless Steel Tubing for General Service
A790/A790M	Standard Specification for Seamless and Welded Ferritic/Austenitic Stainless Steel Pipe
Welded Pipe and Tube	
A134	Pipe, Steel, Electric-Fusion (Arc)-Welded (Sizes NPS 16 and Over)
A135/A135M	Electric-Resistance-Welded Steel Pipe
A139/A139M	Electric-Fusion (Arc)-Welded Steel Pipe (NPS 4 and Over)
A178/A178M	Electric-Resistance-Welded Carbon and Carbon-Manganese Steel Boiler and Superheater Tubes
A214/A214M	Electric-Resistance-Welded Carbon Steel Heat-Exchanger and Condenser Tubes
A249/A249M	Welded Austenitic Steel Boiler, Superheater, Heat-Exchanger, and Condenser Tubes
A254	Copper Brazed Steel Tubing
A358/A358M	Electric-Fusion-Welded Austenitic Chromium-Nickel Stainless Steel Pipe for High-Temperature Service
A409/A409M	Welded Large Diameter Austenitic Steel Pipe for Corrosive or High-Temperature Service
A587	Electric-Resistance-Welded Low-Carbon Steel Pipe for the Chemical Industry
A671	Electric-Fusion-Welded Steel Pipe for Atmospheric and Lower Temperatures
A672	Electric-Fusion-Welded Steel Pipe for High-Pressure Service at Moderate Temperatures
A691	Carbon and Alloy Steel Pipe, Electric-Fusion-Welded for High-Pressure Service at High Temperatures
A928/A928M	Ferritic/Austenitic (Duplex) Stainless Steel Pipe Electric Fusion Welded with Addition of Filler Metal
Fittings	
A234/A234M	Piping Fittings of Wrought Carbon Steel and Alloy Steel for Moderate and High Temperature Service
A403/A403M	Wrought Austenitic Stainless Steel Piping Fittings
A420/A420M	Piping Fittings of Wrought Carbon Steel and Alloy Steel for Low-Temperature Service
A815/A815M	Wrought Ferritic, Ferritic/Austenitic, and Martensitic Stainless Steel Piping Fittings
Plate, Sheet, and Strip	
A240/A240M	Chromium and Chromium-Nickel Stainless Steel Plate, Sheet, and Strip for Pressure Vessels and General Applications
A283/A283M	Low and Intermediate Tensile Strength Carbon Steel Plates
A285/A285M	Pressure Vessel Plates, Carbon Steel, Low- and Intermediate-Tensile Strength
A299/A299M	Pressure Vessel Plates, Carbon Steel, Manganese-Silicon
A387/A387M	Pressure Vessel Plates, Alloy Steel, Chromium-Molybdenum
A515/A515M	Pressure Vessel Plates, Carbon Steel for Intermediate- and Higher-Temperature Service
A516/A516M	Pressure Vessel Plates, Carbon Steel, for Moderate- and Lower-Temperature Service
Rods, Bars, and Shapes	
A276/A276M	Stainless Steel Bars and Shapes
A322	Steel Bars, Alloy, Standard Grades
A479/A479M	Stainless Steel Bars and Shapes for Use in Boilers and Other Pressure Vessels
A564/A564M	Hot-Rolled and Cold-Finished Age-Hardening Stainless Steel Bars and Shapes
A575	Steel Bars, Carbon, Merchant Quality, M-Grades
A576	Steel Bars, Carbon, Hot-Wrought, Special Quality
Structural Components	
A36/A36M	Structural Steel
A125	Steel Springs, Helical, Heat Treated
A229/A229M	Steel Wire, Oil-Tempered for Mechanical Springs
A242/A242M	High-Strength Low Alloy Structural Steel
A992/A992M	Structural Steel Shapes

Table 126.1 Specifications and Standards (Cont'd)

Designator	Title
ASTM Nonferrous Material Specifications	
Castings	
B26/B26M	Aluminum-Alloy Sand Castings
B61	Steam or Valve Bronze Castings
B62	Composition Bronze or Ounce Metal Castings
B108	Aluminum-Alloy Permanent Mold Castings
B148	Aluminum-Bronze Sand Castings
B367	Titanium and Titanium Alloy Castings
B584	Copper Alloy Sand Castings for General Applications
Forgings	
B247 & B247M	Aluminum and Aluminum-Alloy Die, Hand, and Rolled Ring Forgings
B283	Copper and Copper-Alloy Die Forgings (Hot Pressed)
B381	Titanium and Titanium Alloy Forgings
B462	Forged or Rolled UNS N06030, N06022, N06035, N06200, N06059, N10362, N06686, N08020, N08024, N08026, N08367, N10276, N10665, N10675, N10629, N08031, and N06045 Pipe Flanges, Forged Fittings, and Valves and Parts for Corrosive High-Temperature Service
B564	Nickel Alloy Forgings
Seamless Pipe and Tube	
B42	Seamless Copper Pipe, Standard Sizes
B43	Seamless Red Brass Pipe, Standard Sizes
B68 & B68M	Seamless Copper Tube, Bright Annealed
B75	Seamless Copper Tube
B88 & B88M	Seamless Copper Water Tube
B111 & B111M	Copper and Copper-Alloy Seamless Condenser Tubes and Ferrule Stock
B161	Nickel Seamless Pipe and Tube
B163	Seamless Nickel and Nickel-Alloy (UNS N06845) Condenser and Heat-Exchanger Tubes
B165	Nickel-Copper Alloy (UNS N04400) Seamless Pipe and Tube
B167	Nickel-Chromium-Iron Alloys (UNS N06600, N06601, N06603, N06690, N06693, N06025, N06045, and N06696), Nickel-Chromium-Cobalt-Molybdenum Alloy (UNS N06617) and Nickel-Iron-Chromium-Tungsten Alloy (UNS N06674) Seamless Pipe and Tube
B210 & B210M	Aluminum and Aluminum Alloy Drawn Seamless Tubes
B234 & B234M	Aluminum and Aluminum-Alloy Drawn Seamless Tubes for Condensers and Heat Exchangers
B241/B241M	Aluminum and Aluminum-Alloy Seamless Pipe and Seamless Extruded Tube
B251 & B251M	General Requirements for Wrought Seamless Copper and Copper-Alloy Tube
B280	Seamless Copper Tube for Air Conditioning and Refrigeration Field Service
B302	Threadless Copper Pipe, Standard Sizes
B315	Seamless Copper Alloy Pipe and Tube
B407	Nickel-Iron-Chromium Alloy Seamless Pipe and Tube
B423	Nickel-Iron-Chromium-Molybdenum-Copper Alloy (UNS N08825, N08221, and N06845) Seamless Pipe and Tube
B466/B466M	Seamless Copper-Nickel Pipe and Tube
B622	Seamless Nickel and Nickel-Cobalt Alloy Pipe and Tube
B677	UNS N08925, UNS N08354, and UNS N08926 Seamless Pipe and Tube
B690	Iron-Nickel-Chromium-Molybdenum Alloys (UNS N08366 and UNS N08367) Seamless Pipe and Tube
B729	Seamless UNS N08020, UNS N08026, and UNS N08024 Nickel-Alloy Pipe and Tube
B861	Titanium and Titanium Alloy Seamless Pipe
Seamless and Welded Pipe and Tube	
B338	Seamless and Welded Titanium and Titanium Alloy Tubes for Condensers and Heat Exchangers
B444	Nickel-Chromium-Molybdenum-Columbium Alloy (UNS N06625 and UNS N06852) and Nickel-Chromium-Molybdenum-Silicon Alloy (UNS N06219) Pipe and Tube

Table 126.1 Specifications and Standards (Cont'd)

Designator	Title
ASTM Nonferrous Material Specifications (Cont'd)	
Welded Pipe and Tube	
B464	Welded (UNS N08020, N08024, and N08026) Alloy Pipe
B467	Welded Copper-Nickel Pipe
B468	Welded (UNS N08020, N08024, and N08026) Alloy Tubes
B546	Electric Fusion-Welded Ni-Cr-Co-Mo Alloy (UNS N06617), Ni-Fe-Cr-Si Alloys (UNS N08330 and UNS N08332), Ni-Cr-Fe-Al Alloy (UNS N06603), Ni-Cr-Fe Alloy (UNS N06025), and Ni-Cr-Fe-Si Alloy (UNS N06045) Pipe
B547/B547M	Aluminum and Aluminum-Alloy Formed and Arc-Welded Round Tube
B608	Welded Copper-Alloy Pipe
B619	Welded Nickel and Nickel-Cobalt Alloy Pipe
B626	Welded Nickel and Nickel-Cobalt Alloy Tube
B673	UNS N08925, UNS N08354, and UNS N08926 Welded Pipe
B674	UNS N08925, UNS N08354, and UNS N08926 Welded Tube
B675	UNS N08367 Welded Pipe
B676	UNS N08367 Welded Tube
B704	Welded UNS N06625, N06219, and N08825 Alloy Tubes
B705	Nickel-Alloy (UNS N06625, N06219, and N08825) Welded Pipe
B804	UNS N08367 and UNS N08926 Welded Pipe
B862	Titanium and Titanium Alloy Welded Pipe
Fittings	
B361	Factory-Made Wrought Aluminum and Aluminum-Alloy Welding Fittings
B366	Factory-Made Wrought Nickel and Nickel Alloy Fittings
Plate, Sheet, and Strip	
B168	Nickel-Chromium-Iron Alloys (UNS N06600, N06601, N06603, N06690, N06693, N06025, N06045, and N06696), Nickel-Chromium-Cobalt-Molybdenum Alloy (UNS N06617), and Nickel-Iron-Chromium-Tungsten Alloy (UNS N06674) Plate, Sheet, and Strip
B171/B171M	Copper-Alloy Plate and Sheet for Pressure Vessels, Condensers, and Heat Exchangers
B209	Aluminum and Aluminum-Alloy Sheet and Plate
B265	Titanium and Titanium-Alloy Strip, Sheet, and Plate
B409	Nickel-Iron-Chromium Alloy Plate, Sheet, and Strip
B424	Ni-Fe-Cr-Mo-Cu Alloy (UNS N08825, UNS N08221, and UNS N06845) Plate, Sheet, and Strip
B435	UNS N06002, UNS N06230, UNS N12160, and UNS R30556 Plate, Sheet, and Strip
B443	Nickel-Chromium-Molybdenum-Columbium Alloy (UNS N06625) and Nickel-Chromium-Molybdenum-Silicon Alloy (UNS N06219) Plate, Sheet, and Strip
B463	UNS N08020 Alloy Plate, Sheet, and Strip
B575	Low-Carbon Nickel-Chromium-Molybdenum, Low-Carbon Nickel-Chromium-Molybdenum-Copper, Low-Carbon Nickel-Chromium-Molybdenum-Tantalum, and Low-Carbon Nickel-Chromium-Molybdenum-Tungsten Alloy Plate, Sheet, and Strip
B625	UNS N08925, UNS N08031, UNS N08932, UNS N08926, UNS N08354, and UNS R20033 Plate, Sheet, and Strip
B688	Chromium-Nickel-Molybdenum-Iron (UNS N08366 and UNS N08367) Plate, Sheet, and Strip
Rods, Bars, and Shapes	
B150/B150M	Aluminum Bronze Rod, Bar, and Shapes
B151/B151M	Copper-Nickel-Zinc Alloy (Nickel Silver) and Copper-Nickel Rod and Bar
B166	Nickel-Chromium-Iron Alloys (UNS N06600, N06601, N06603, N06690, N06693, N06025, N06045, and N06696), Nickel-Chromium-Cobalt-Molybdenum Alloy (UNS N06617), and Nickel-Iron-Chromium-Tungsten Alloy (UNS N06674) Rod, Bar, and Wire
B221	Aluminum and Aluminum Alloy Extruded Bars, Rods, Wire, Profiles, and Tubes
B348	Titanium and Titanium Alloy Bars and Billets
B408	Nickel-Iron-Chromium Alloy Rod and Bar
B425	Ni-Fe-Cr-Mo-Cu Alloy (UNS N08825, UNS N08221, and UNS N06845) Rod and Bar
B446	Nickel-Chromium-Molybdenum-Columbium Alloy (UNS N06625), Nickel-Chromium-Molybdenum-Silicon Alloy (UNS N06214), and Nickel-Chromium-Molybdenum-Tungsten Alloy (UNS N06650) Rod and Bar
B473	UNS N08020, UNS N08024, and UNS N08026 Nickel Alloy Bar and Wire
B572	UNS N06002, UNS N06230, UNS N12160, and UNS R30556 Rod

Table 126.1 Specifications and Standards (Cont'd)

Designator	Title
ASTM Nonferrous Material Specifications (Cont'd)	
Rods, Bars, and Shapes (Cont'd)	
B574	Low-Carbon Nickel-Chromium-Molybdenum, Low-Carbon Nickel-Molybdenum-Chromium-Tantalum, Low-Carbon Nickel-Chromium-Molybdenum-Copper, and Low-Carbon Nickel-Chromium-Molybdenum-Tungsten Alloy Rod
B649	Ni-Fe-Cr-Mo-Cu-N Low-Carbon Alloys (UNS N08925, UNS N08031, UNS N08354, and UNS N08926), Cr-Ni-Fe-N Low-Carbon Alloy (UNS R20033) Bar and Wire, and Ni-Cr-Fe-Mo-N Alloy (UNS N08936) Wire
B691	Iron-Nickel-Chromium-Molybdenum Alloys (UNS N08366 and UNS N08367) Rod, Bar, and Wire
Solder	
B32	Solder Metal
B828	Standard Practice for Making Capillary Joints by Soldering of Copper and Copper Alloy Tube and Fittings

ASTM Standard Test Methods

D323	Standard Test Method for Vapor Pressure of Petroleum Products (Reid Method)
E94	Standard Guide for Radiographic Examination
E125	Standard Reference Photographs for Magnetic Particle Indications on Ferrous Castings
E186	Standard Reference Radiographs for Heavy-Walled (2 to 4½-in. [51 to 114-mm]) Steel Castings
E280	Standard Reference Radiographs for Heavy-Walled (4½ to 12-in. [114 to 305-mm]) Steel Castings
E446	Standard Reference Radiographs for Steel Castings Up to 2 in. [51 mm] in Thickness

API Specifications

Seamless and Welded Pipe

5L	Line Pipe
570	Piping Inspection Code: In-service Inspection, Rating, Repair, and Alteration of Piping Systems, Third Edition

American National Standard

Z223.1	National Fuel Gas Code (ANSI/NFPA 54)
--------	---------------------------------------

MSS Standard Practices

SP-6	Standard Finishes for Contact Faces of Pipe Flanges and Connecting-End Flanges of Valves and Fittings
SP-9	Spot-Facing for Bronze, Iron and Steel Flanges
SP-25	Standard Marking System for Valves, Fittings, Flanges and Unions
SP-42 [Note (1)]	Corrosion Resistant Gate, Globe, Angle and Check Valves With Flanged and Butt Weld Ends (Classes 150, 300 & 600)
SP-43	Wrought and Fabricated Butt-Welding Fittings for Low Pressure, Corrosion Resistant Applications
SP-45	Bypass and Drain Connections
SP-51	Class 150 LW Corrosion Resistant Flanges and Cast Flanged Fittings
SP-53	Quality Standard for Steel Castings and Forgings for Valves, Flanges, and Fittings and Other Piping Components — Magnetic Particle Examination Method
SP-54	Quality Standard for Steel Castings for Valves, Flanges, and Fittings and Other Piping Components — Radiographic Examination Method
SP-55	Quality Standard for Steel Castings for Valves, Flanges, and Fittings and Other Piping Components — Visual Method for Evaluation of Surface Irregularities
SP-58	Pipe Hangers and Supports — Materials, Design, Manufacture, Selection, Application, and Installation
SP-61	Pressure Testing of Valves
SP-67 [Note (1)]	Butterfly Valves
SP-68	High Pressure Butterfly Valves with Offset Design
SP-75	High-Strength, Wrought, Butt-Welding Fittings
SP-79	Socket Welding Reducer Inserts
SP-80	Bronze Gate, Globe, Angle and Check Valves
SP-83	Class 3000 and 6000 Pipe Unions, Socket Welding and Threaded (Carbon Steel, Alloy Steel, Stainless Steels, and Nickel Alloys)
SP-88	Diaphragm Valves

Table 126.1 Specifications and Standards (Cont'd)

Designator	Title
MSS Standard Practices (Cont'd)	
SP-93	Quality Standard for Steel Castings and Forgings for Valves, Flanges, and Fittings and Other Piping Components — Liquid Penetrant Examination Method
SP-94	Quality Standard for Ferritic and Martensitic Steel Castings for Valves, Flanges, and Fittings and Other Piping Components — Ultrasonic Examination Method
SP-95	Swage(d) Nipples and Bull Plugs
SP-97	Integrally Reinforced Forged Branch Outlet Fittings — Socket Welding, Threaded and Buttwelding Ends
SP-105	Instrument Valves for Code Applications
SP-106	Cast Copper Alloy Flanges and Flanged Fittings: Class 125, 150, and 300
ASME Codes & Standards	
...	ASME Boiler and Pressure Vessel Code
B1.1	Unified Inch Screw Threads
B1.13M	Metric Screw Threads — M Profile
B1.20.1	Pipe Threads, General Purpose (Inch)
B1.20.3	Dryseal Pipe Threads (Inch)
B16.1	Cast Iron Pipe Flanges and Flanged Fittings — 25, 125, 250 & 800 Classes
B16.3	Malleable Iron Threaded Fittings
B16.4	Gray Iron Threaded Fittings
B16.5	Pipe Flanges and Flanged Fittings
B16.9	Factory-Made Wrought Buttwelding Fittings
B16.10	Face-to-Face and End-to-End Dimensions of Valves
B16.11	Forged Fittings, Socket-Welding and Threaded
B16.14	Ferrous Pipe Plugs, Bushings, and Locknuts With Pipe Threads
B16.15	Cast Bronze Threaded Fittings, Classes 125 and 250
B16.18	Cast Copper Alloy Solder-Joint Pressure Fittings
B16.20	Metallic Gaskets for Pipe Flanges — Ring Joint, Spiral Wound, and Jacketed
B16.21	Nonmetallic Flat Gaskets for Pipe Flanges
B16.22	Wrought Copper and Copper Alloy Solder Joint Pressure Fittings
B16.24	Cast Copper Alloy Pipe Flanges and Flanged Fittings — Class 150, 300, 400, 600, 900, 1500, and 2500
B16.25	Butt Welding Ends
B16.26	Cast Copper Alloy Fittings for Flared Copper Tubes
B16.34	Valves — Flanged, Threaded, and Welding End
B16.42	Ductile Iron Pipe Flanges and Flanged Fittings — Classes 150 and 300
B16.47	Large Diameter Steel Flanges
B16.48	Steel Line Blanks
B16.50	Wrought Copper and Copper Alloy Braze-Joint Pressure Fittings
B18.2.1	Square and Hex Bolts and Screws — Inch Series
B18.2.2	Square and Hex Nuts (Inch Series)
B18.2.3.5M	Metric Hex Bolts
B18.2.3.6M	Metric Heavy Hex Bolts
B18.2.4.6M	Hex Nuts, Heavy, Metric
B18.21.1	Lock Washers (Inch Series)
B18.22M	Washers, Metric Plain
B18.22.1 [Note (2)]	Plain Washers
B31.3	Process Piping
B31.4	Pipeline Transportation Systems for Liquid Hydrocarbons and Other Liquids
B31.8	Gas Transmission and Distribution Piping Systems
B31E	Standard for the Seismic Design and Retrofit of Above-Ground Piping Systems
B31J	Standard Test Method for Determining Stress Intensification Factors (<i>i</i> -Factors) for Metallic Piping Components
B31T	Standard Toughness Requirements for Piping
B36.10M	Welded and Seamless Wrought Steel Pipe
B36.19M	Stainless Steel Pipe
TDP-1	Recommended Practices for the Prevention of Water Damage to Steam Turbines Used for Electric Power Generation — Fossil Fueled Plants

Table 126.1 Specifications and Standards (Cont'd)

Designator	Title
AWS Specifications	
A3.0	Standard Welding Terms and Definitions
D10.10	Recommended Practices for Local Heating of Welds in Piping and Tubing
QC1	Standard for AWS Certification of Welding Inspectors
AWWA and ANSI/AWWA Standards	
C110/A21.10	Ductile-Iron and Gray-Iron Fittings, 3 in. Through 48 in. (76 mm Through 1200 mm), for Water and Other Liquids
C111/A21.11	Rubber-Gasket Joints for Ductile-Iron Pressure Pipe and Fittings
C115/A21.15	Flanged Ductile-Iron Pipe With Threaded Flanges
C150/A21.50	Thickness Design of Ductile-Iron Pipe
C151/A21.51	Ductile-Iron Pipe, Centrifugally Cast, for Water
C153/A21.53	Ductile-Iron Compact Fittings, 3 in. Through 24 in. (76 mm Through 610 mm) and 54 in. Through 64 in. (1,400 mm Through 1,600 mm), for Water Service
C200	Steel Water Pipe—6 in. (150 mm) and Larger
C207	Steel Pipe Flanges for Waterworks Service—Sizes 4 in. Through 144 in. (100 mm Through 3,600 mm)
C208	Dimensions for Fabricated Steel Water Pipe Fittings
C300	Reinforced Concrete Pressure Pipe, Steel-Cylinder Type, for Water and Other Liquids (Includes Addendum C300a-93.)
C301	Prestressed Concrete Pressure Pipe, Steel-Cylinder Type, for Water and Other Liquids
C302	Reinforced Concrete Pressure Pipe, Noncylinder Type, for Water and Other Liquids
C304	Design of Prestressed Concrete Cylinder Pipe
C500	Metal-Seated Gate Valves for Water Supply Service
C504 [Note (1)]	Rubber Seated Butterfly Valves
C509	Resilient-Seated Gate Valves for Water Supply Service
C600	Installation of Ductile-Iron Water Mains and Their Appurtenances
C606	Grooved and Shouldered Joints
National Fire Codes	
NFPA 85	Boiler and Combustion Systems Hazards Code
NFPA 1963	Standard for Fire Hose Connections
PFI Standards	
ES-16	Access Holes and Plugs for Radiographic Inspection of Pipe Welds
ES-24	Pipe Bending Methods, Tolerances, Process and Material Requirements
FCI Standard	
79-1	Proof of Pressure Ratings for Pressure Regulators

GENERAL NOTES:

- (a) For boiler external piping application, see para. 123.2.2.
- (b) For all other piping, materials conforming to an ASME SA or SB specification may be used interchangeably with material specified to an ASTM A or B specification of the same number listed in Table 126.1.
- (c) The approved year of issue of the specifications and standards is not given in this Table. This information is given in Mandatory Appendix F of this Code.
- (d) The addresses and phone numbers of organizations whose specifications and standards are listed in this Table are given at the end of Mandatory Appendix F.

NOTES:

- (1) See para. 107.1(D) for valve stem retention requirements.
- (2) ANSI B18.22.1 is nonmetric.

Chapter V

Fabrication, Assembly, and Erection

127 WELDING

127.1 General

Piping systems shall be constructed in accordance with the requirements of this Chapter and of materials that have been manufactured in accordance with the requirements of Chapter IV. These requirements apply to all fabrication, assembly, and erection operations, whether performed in a shop or at a construction site. The following applies essentially to the welding of ferrous materials. The welding of aluminum, copper, etc., requires different preparations and procedures.

127.1.1 The welding processes that are to be used under this part of this Code shall meet all the test requirements of Section IX of the ASME Boiler and Pressure Vessel Code.

127.2 Material

127.2.1 Electrodes and Filler Metal. Welding electrodes and filler metal, including consumable inserts, shall conform to the requirements of the ASME Boiler and Pressure Vessel Code, Section II, Part C. An electrode or filler metal not conforming to the above may be used provided the WPS and the welders and welding operators who will follow the WPS have been qualified as required by ASME Section IX. Unless otherwise specified by the designer, welding electrodes and filler metals used shall produce weld metal that complies with the following:

(A) The nominal tensile strength of the weld metal shall equal or exceed the minimum specified tensile strength of the base metals being joined.

(B) If base metals of different tensile strengths are to be joined, the nominal tensile strength of the weld metal shall equal or exceed the minimum specified tensile strength of the weaker of the two.

(C) The nominal chemical analysis of the weld metal shall be similar to the nominal chemical analysis of the base metal, including consideration of both major and essential minor alloying elements [e.g., 2¼% Cr, 1% Mo steels should be joined using 2¼% Cr, 1% Mo filler metals; see also para. 124.2(D)].

(D) If base metals of different chemical analysis are being joined, the nominal chemical analysis of the weld metal shall be similar to either base metal or an intermediate composition, except as specified below for austenitic steels joined to ferritic steels.

(E) When austenitic steels are joined to ferritic steels, the weld metal shall have an austenitic structure.

(F) For nonferrous metals, the weld metal shall be that recommended by the manufacturer of the nonferrous metal or by industry associations for that metal.

(G) Filler metals not meeting the requirements of (A) through (F) above may be accepted by agreement between the fabricator/erector and the designer. Examples of conditions where this may apply include (but may not be limited to) where unusual materials or combinations of materials are used; where highly corrosive environments may require a more electrochemically noble weld metal; where dissimilar materials are welded; or where it is desired to achieve a weld with different mechanical properties than the base material.

127.2.2 Backing Rings. Backing rings, when used, shall conform to the following requirements:

(A) *Ferrous Rings.* Ferrous metal backing rings that become a permanent part of the weld shall be made from material of weldable quality, compatible with the base material and the sulfur content shall not exceed 0.05%.

(A.1) Backing rings may be of the continuous machined or split band type.

(A.2) If two abutting surfaces are to be welded to a third member used as a backing ring and one or two of the three members are ferritic and the other member or members are austenitic, the satisfactory use of such materials shall be determined by the WPS qualified as required in para. 127.5.

(A.3) Backing strips used at longitudinal welded joints shall be removed.

(B) *Nonferrous and Nonmetallic Rings.* Backing rings of nonferrous or nonmetallic materials may be used for backing provided they are included in a WPS as required in para. 127.5. Nonmetallic or nonfusing rings shall be removed.

127.2.3 Consumable Inserts. Consumable inserts may be used provided they are made from material compatible with the chemical and physical properties of the base material. Qualification of the WPS shall be as required by para. 127.5.

127.3 Preparation for Welding

(A) *End Preparation*

(A.1) Oxygen or arc cutting is acceptable only if the cut is reasonably smooth and true, and all slag is

Fig. 127.3 Butt Welding of Piping Components With Internal Misalignment

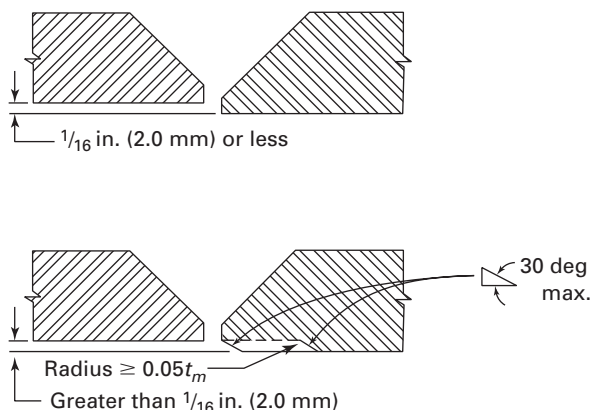

cleaned from the flame cut surfaces. Discoloration that may remain on the flame cut surface is not considered to be detrimental oxidation.

(A.2) Butt-welding end preparation dimensions contained in ASME B16.25 or any other end preparation that meets the WPS are acceptable.

(A.3) If piping component ends are bored, such boring shall not result in the finished wall thickness after welding less than the minimum design thickness. Where necessary, weld metal of the appropriate analysis may be deposited on the inside or outside of the piping component to provide sufficient material for machining to ensure satisfactory fitting of rings.

(A.4) If the piping component ends are upset, they may be bored to allow for a completely recessed backing ring, provided the remaining net thickness of the finished ends is not less than the minimum design thickness.

(B) *Cleaning.* Surfaces for welding shall be clean and shall be free from paint, oil, rust, scale, or other material that is detrimental to welding.

(C) *Alignment.* The inside diameters of piping components to be butt welded shall be aligned as accurately as is practicable within existing commercial tolerances on diameters, wall thicknesses, and out-of-roundness. Alignment shall be preserved during welding. The internal misalignment of the ends to be joined shall not exceed $\frac{1}{16}$ in. (2.0 mm) unless the piping design specifically states a different allowable misalignment.

When the internal misalignment exceeds the allowable, it is preferred that the component with the wall extending internally be internally trimmed per Fig. 127.3. However, trimming shall result in a piping component thickness not less than the minimum design thickness, and the change in contour shall not exceed 30 deg (see Fig. 127.3).

(D) *Spacing.* The root opening of the joint shall be as given in the WPS.

(E) *Socket Weld Assembly.* In assembly of the joint before welding, the pipe or tube shall be inserted into the socket to the maximum depth and then withdrawn approximately $\frac{1}{16}$ in. (2.0 mm) away from contact between the end of the pipe and the shoulder of the socket [see Figs. 127.4.4(B) and (C)]. In sleeve-type joints without internal shoulder, there shall be a distance of approximately $\frac{1}{16}$ in. (2.0 mm) between the butting ends of the pipe or tube.

The fit between the socket and the pipe shall conform to applicable standards for socket weld fittings and in no case shall the inside diameter of the socket or sleeve exceed the outside diameter of the pipe or tube by more than 0.080 in. (2.0 mm).

127.4 Procedure

127.4.1 General

(A) Qualification of the WPS to be used, and of the performance of welders and operators, is required, and shall comply with the requirements of para. 127.5.

(B) No welding shall be done if there is impingement of rain, snow, sleet, or high wind on the weld area.

(C) Tack welds permitted to remain in the finished weld shall be made by a qualified welder. Tack welds made by an unqualified welder shall be removed. Tack welds that remain shall be made with an electrode and WPS that is the same as or equivalent to the electrode and WPS to be used for the first pass. The stopping and starting ends shall be prepared by grinding or other means so that they can be satisfactorily incorporated into the final weld. Tack welds that have cracked shall be removed.

(D) *CAUTION:* Arc strikes outside the area of the intended weld should be avoided on any base metal.

127.4.2 Girth Butt Welds

(A) Girth butt welds shall be complete penetration welds and shall be made with a single vee, double vee, or other suitable type of groove, with or without backing rings or consumable inserts. The depth of the weld measured between the inside surface of the weld preparation and the outside surface of the pipe shall not be less than the minimum thickness required by Chapter II for the particular size and wall of pipe used.

(B) To avoid abrupt transitions in the contour of the finished weld, the requirements of (B.1) through (B.4) below shall be met.

(B.1) When components with different outside diameters or wall thicknesses are welded together, the welding end of the component with the larger outside diameter shall fall within the envelope defined by solid lines in Fig. 127.4.2. The weld shall form a gradual transition not exceeding a slope of 30 deg from the smaller to the larger diameter component. This condition may be met by adding welding filler material, if necessary, beyond what would otherwise be the edge of the weld.

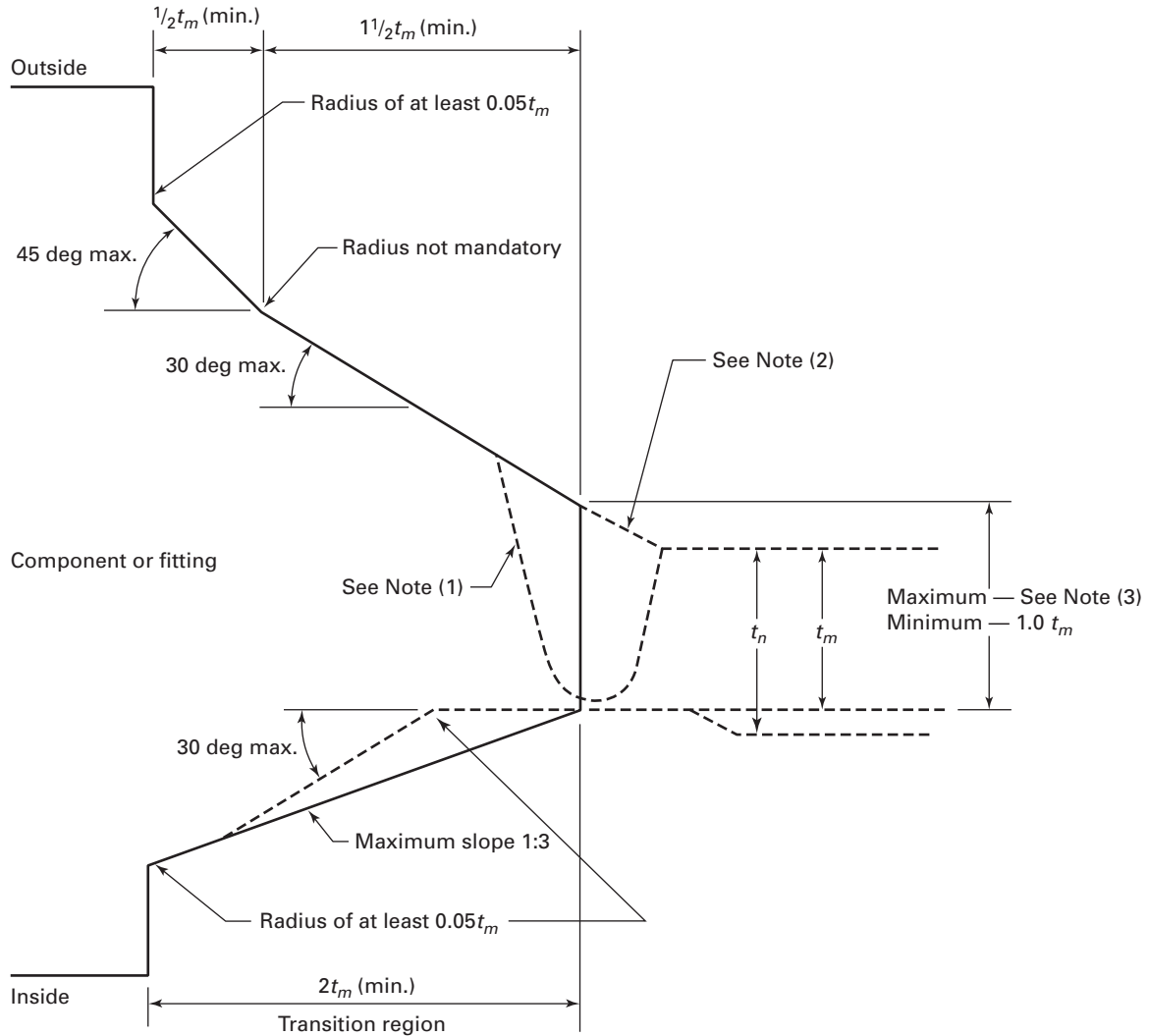
Fig. 127.4.2 Welding End Transition — Maximum Envelope**GENERAL NOTES:**

- (a) The value of t_m is whichever of the following is applicable:
 (1) as defined in para. 104.1.2(A) or para. 104.1.4
 (2) the minimum ordered wall thickness of the cylindrical welding end of a component or fitting (or the thinner of the two) when the joint is between two components
- (b) The maximum envelope is defined by solid lines.

NOTES:

- (1) Weld is shown for illustration only.
 (2) The weld transition and weld reinforcement shall comply with paras. 127.4.2(B) and (C.2) and may be outside the maximum envelope.
 (3) The maximum thickness at the end of the component is
 (a) the greater of $[t_m + 0.16 \text{ in. (4 mm)}]$ or $1.15t_m$ when ordered on a minimum wall basis
 (b) the greater of $[t_m + 0.16 \text{ in. (4 mm)}]$ or $1.10t_m$ when ordered on a nominal wall basis

(B.2) When both components to be welded (other than pipe to pipe) have a transition from a thicker section to the weld end preparation, the included angle between the surface of the weld and the surface of either of the components shall not be less than 150 deg. Refer to para. 119.3(B) for additional concerns related to this design.

(B.3) When welding pipe to pipe, the surface of the weld shall, as a minimum, be flush with the outer surface of the pipe, except as permitted in para. 127.4.2(B.4).

(B.4) For welds made without the addition of filler metal, concavity shall be limited to $\frac{1}{32}$ in. (1 mm) below the outside surface of the pipe, but shall not encroach upon minimum required thickness.

(C) As-welded surfaces are permitted; however, the surface of welds shall be sufficiently free from coarse ripples, grooves, overlaps, abrupt ridges, and valleys to meet the following:

(C.1) The surface condition of the finished welds shall be suitable for the proper interpretation of radiographic and other nondestructive examinations when nondestructive examinations are required by Table 136.4. In those cases where there is a question regarding the surface condition on the interpretation of a radiographic film, the film shall be compared to the actual weld surface for interpretation and determination of acceptability.

(C.2) Reinforcements are permitted in accordance with Table 127.4.2.

(C.3) Undercut on the surface of girth butt welds shall not exceed $\frac{1}{32}$ in. (1.0 mm) and shall not encroach on the minimum required section thickness.

(C.4) If the surface of the weld requires grinding to meet the above criteria, care shall be taken to avoid reducing the weld or base material below the minimum required thickness.

(C.5) Concavity on the root side of a single welded circumferential butt weld is permitted when the resulting thickness of the weld is at least equal to the thickness of the thinner member of the two sections being joined and the contour of the concavity is smooth without sharp edges. The internal condition of the root surface of a girth weld, which has been examined by radiography, is acceptable only when there is a gradual change in the density, as indicated in the radiograph. If a girth weld is not designated to be examined by radiography, a visual examination may be performed at welds that are readily accessible.

127.4.3 Longitudinal Butt Welds. Longitudinal butt welds not covered by the applicable material specifications listed in Table 126.1 shall meet the requirements for girth butt welds in para. 127.4.2, except that undercut on the surface of longitudinal butt welds, fabricated in accordance with the requirements of this Code, is not permitted. For longitudinal welds and spiral welds in pipe intended for sustained operation in the creep range

(see paras. 104.1.1 and 123.4, and Table 102.4.7), any welding using the SAW process shall use a flux with a basicity index ≥ 1.0 .

127.4.4 Fillet Welds. In making fillet welds, the weld metal shall be deposited in such a way as to secure adequate penetration into the base metal at the root of the weld.

Fillet welds may vary from convex to concave. The size of a fillet weld is determined as shown in Fig. 127.4.4(A). Typical minimum fillet weld details for slip-on flanges and socket-welding components are shown in Figs. 127.4.4(B) and (C).

127.4.5 Seal Welds. Where seal welding of threaded joints is performed, threads shall be entirely covered by the seal weld. Seal welding shall be done by qualified welders.

127.4.8 Welded Branch Connections

(16)

(A) Welded branch connections shall be made with full penetration welds, except as allowed in para. 127.4.8(F). Figures 127.4.8(A), (B), and (C) show typical details of branch connections with and without added reinforcement. No attempt has been made to show all acceptable types of construction and the fact that a certain type of construction is illustrated does not indicate that it is recommended over other types not illustrated.

(B) Figure 127.4.8(D) shows basic types of weld attachments used in the fabrication of branch connections. The location and minimum size of these attachment welds shall conform to the requirements of para. 127.4.8. Welds shall be calculated in accordance with para. 104.3.1 but shall not be less than the sizes shown in Fig. 127.4.8(D).

The notations and symbols used in this paragraph, Fig. 127.4.8(D), and Fig. 127.4.8(E) are as follows:

- t_c = the smaller of $\frac{1}{4}$ in. (6.0 mm) or $0.7t_{nb}$
- t_{min} = the smaller of t_{nb} or t_{nr}
- t_{nb} = nominal thickness of branch wall, in. (mm)
- t_{nh} = nominal thickness of header wall, in. (mm)
- t_{nr} = nominal thickness of reinforcing element (ring or saddle), in. (mm)

(C) Figure 127.4.8(F) shows branch connections made by welding half couplings or adapters directly to the run pipe.

Figure 127.4.8(E) shows branch connections using specifically reinforced branch outlet fittings welded directly to the run pipe. These branch connection fittings, half couplings, or adapters, which abut the outside surface of the run wall, or which are inserted through an opening cut in the run wall, shall have opening and branch contour to provide a good fit and shall be attached by means of full penetration groove welds except as otherwise permitted in (F) below.

The full penetration groove welds shall be finished with cover fillet welds and meet the requirements of

Table 127.4.2 Reinforcement of Girth and Longitudinal Butt Welds

Thickness of Base Metal, in. (mm)	Maximum Thickness of Reinforcement for Design Temperature					
	> 750°F (400°C)		350°F–750°F (175°C–400°C)		< 350°F (175°C)	
	in.	mm	in.	mm	in.	mm
Up to $\frac{1}{8}$ (3.0), incl.	$\frac{1}{16}$	2.0	$\frac{3}{32}$	2.5	$\frac{3}{16}$	5.0
Over $\frac{1}{8}$ to $\frac{3}{16}$ (3.0 to 5.0), incl.	$\frac{1}{16}$	2.0	$\frac{1}{8}$	3.0	$\frac{3}{16}$	5.0
Over $\frac{3}{16}$ to $\frac{1}{2}$ (5.0 to 13.0), incl.	$\frac{1}{16}$	2.0	$\frac{5}{32}$	4.0	$\frac{3}{16}$	5.0
Over $\frac{1}{2}$ to 1 (13.0 to 25.0), incl.	$\frac{3}{32}$	2.5	$\frac{3}{16}$	5.0	$\frac{3}{16}$	5.0
Over 1 to 2 (25.0 to 50.0), incl.	$\frac{1}{8}$	3.0	$\frac{1}{4}$	6.0	$\frac{1}{4}$	6.0
Over 2 (50.0)	$\frac{5}{32}$	4.0	The greater of $\frac{1}{4}$ in. (6 mm) or $\frac{1}{8}$ times the width of the weld in inches (millimeters).			

GENERAL NOTES:

- For double welded butt joints, this limitation on reinforcement given above shall apply separately to both inside and outside surfaces of the joint.
- For single welded butt joints, the reinforcement limits given above shall apply to the outside surface of the joint only.
- The thickness of weld reinforcement shall be based on the thickness of the thinner of the materials being joined.
- The weld reinforcement thicknesses shall be determined from the higher of the abutting surfaces involved.
- Weld reinforcement may be removed if so desired.

Fig. 127.4.4(A) Fillet Weld Size

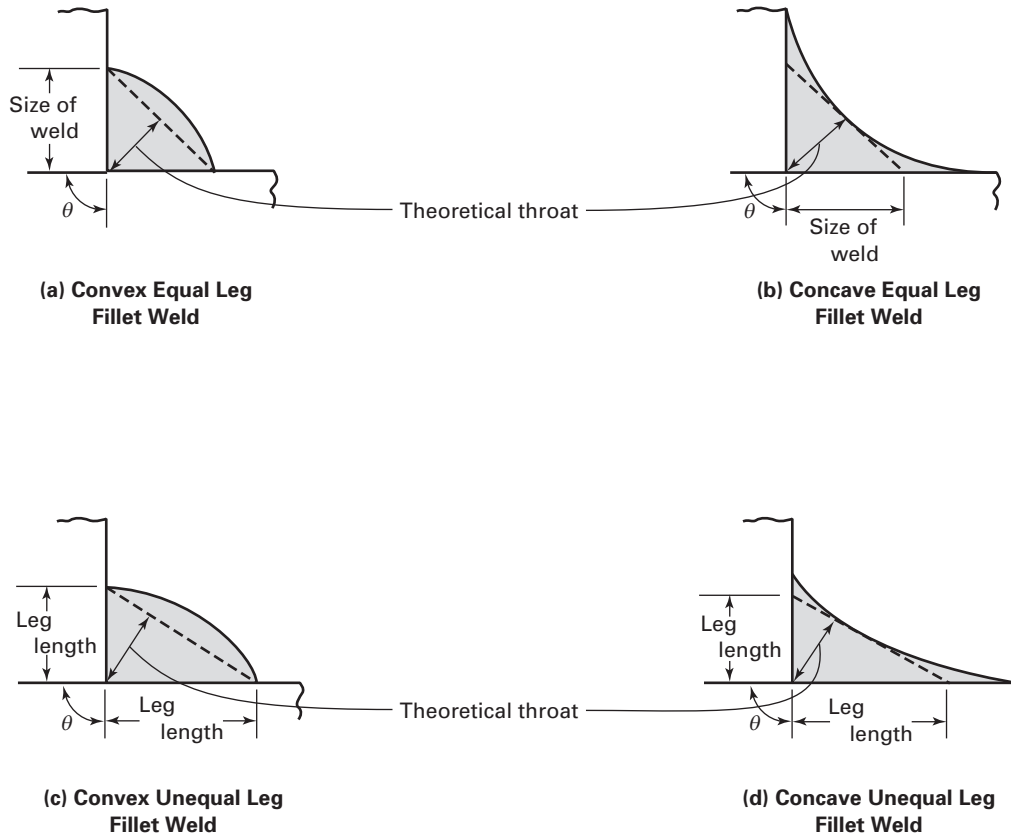

GENERAL NOTES:

- The "size" of an equal leg fillet weld shall be described by the leg length of the largest inscribed isosceles triangle.
- The "size" of an unequal leg fillet weld shall be described using both leg lengths and their location on the members to be joined.
- Angle θ , as noted in the above illustrations, may vary from the 90 deg angle as shown based on the angle between the surfaces to be welded.
- For an equal leg fillet weld where the angle q between the members being joined is 90 deg, the theoretical throat shall be $0.7 \times$ leg length. For other fillet welds, the theoretical throat shall be based on the leg lengths and the angle q between the members to be joined.
- For all fillet welds, particularly unequal leg fillet welds with angle θ less than 90 deg, the theoretical throat shall lie within the cross section of the deposited weld metal and shall not be less than the minimum distance through the weld.

Fig. 127.4.4(B) Welding Details for Slip-On and Socket-Welding Flanges; Some Acceptable Types of Flange Attachment Welds

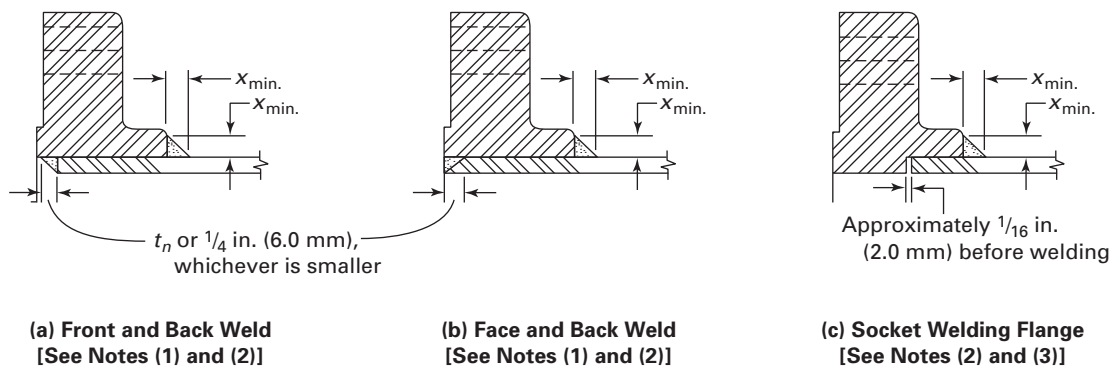

t_n = nominal pipe wall thickness
 $x_{min.}$ = $1.4t_n$ or thickness of the hub, whichever is smaller

NOTES:

- (1) Refer to para. 122.1.1(F) for limitations of use.
- (2) Refer to para. 104.5.1 for limitations of use.
- (3) Refer to para. 122.1.1(H) for limitations of use.

Fig. 127.4.4(C) Minimum Welding Dimensions Required for Socket Welding Components Other Than Flanges

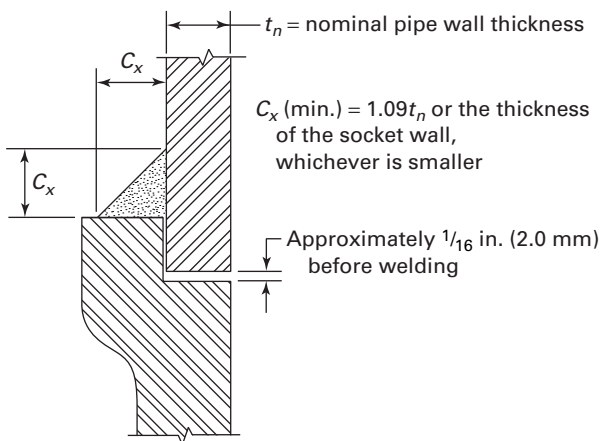

Fig. 127.4.8(B) Typical Welded Branch Connection With Additional Reinforcement

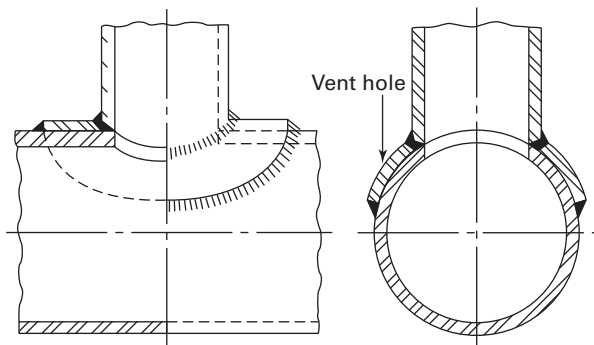

Fig. 127.4.8(C) Typical Welded Angular Branch Connection Without Additional Reinforcement

Fig. 127.4.8(A) Typical Welded Branch Connection Without Additional Reinforcement

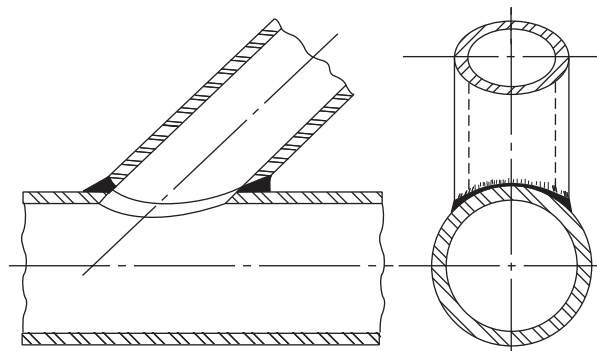
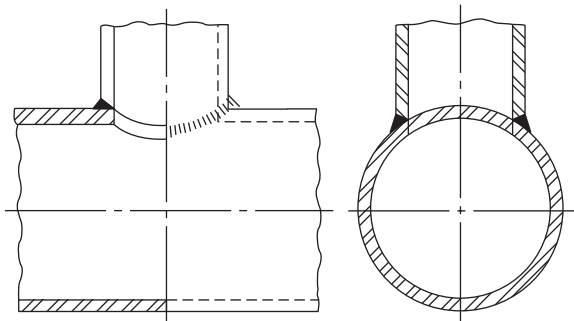
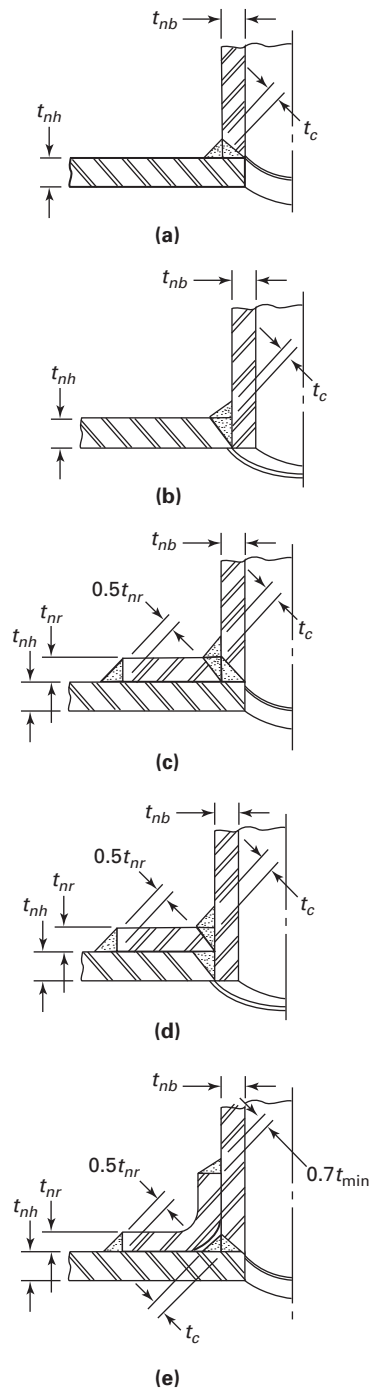

Fig. 127.4.8(D) Some Acceptable Types of Welded Branch Attachment Details Showing Minimum Acceptable Welds



GENERAL NOTE: Weld dimensions may be larger than the minimum values shown here.

Fig. 127.4.8(E) Some Acceptable Details for Integrally Reinforced Outlet Fittings

(16)

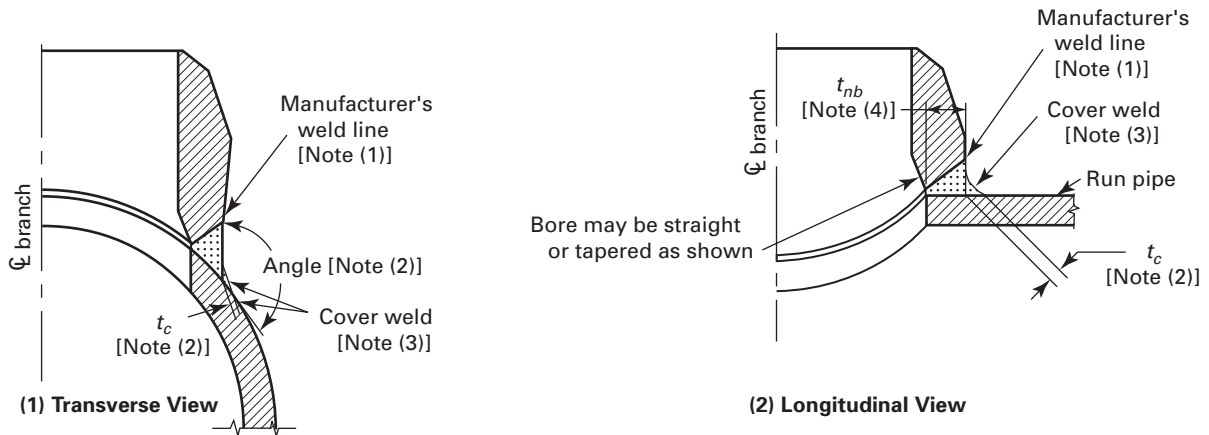

(a) 90 deg Branch Fitting

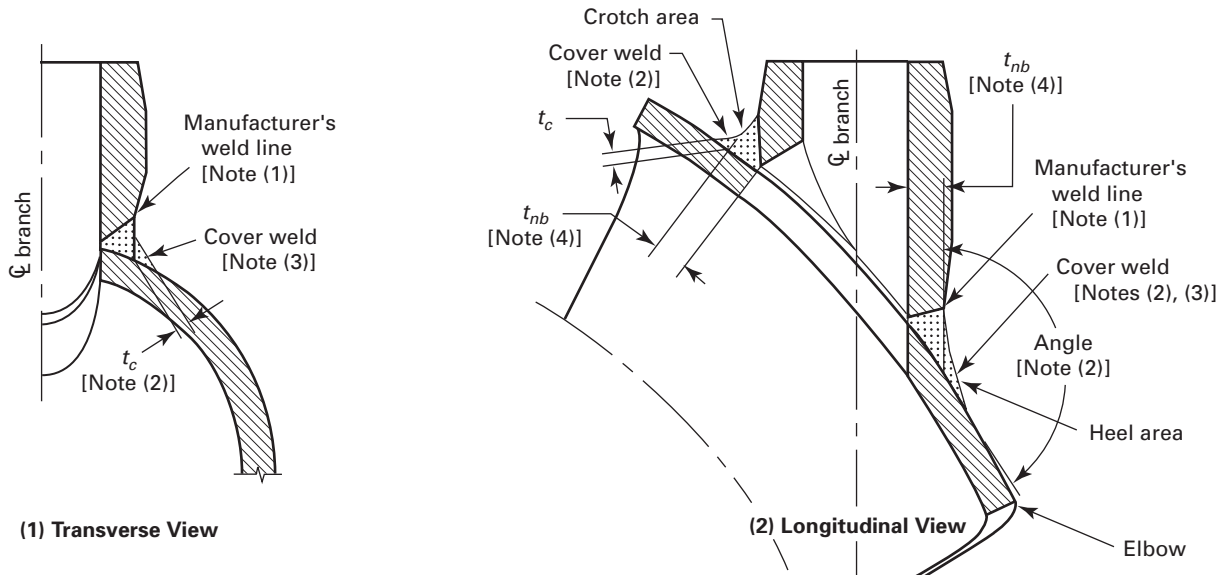

(b) Elbow Branch Fitting

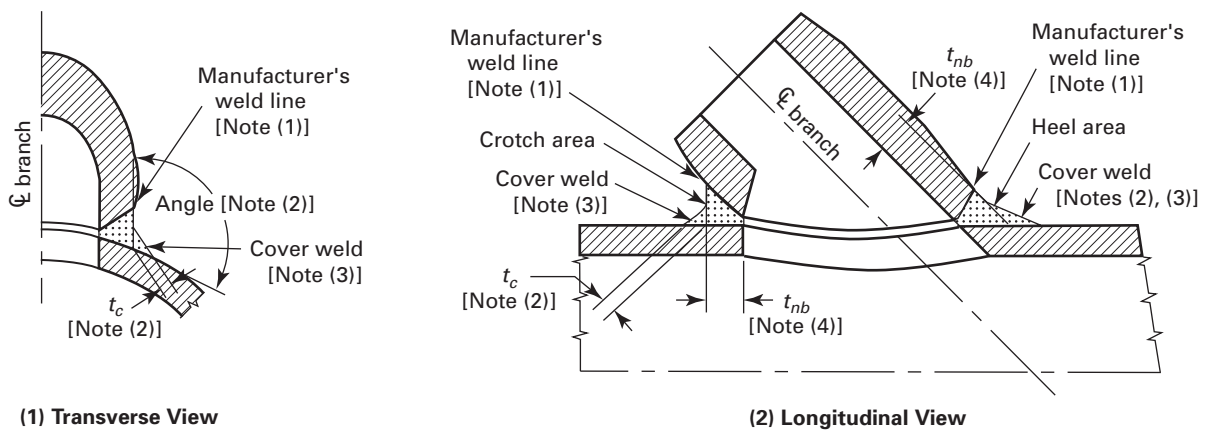

(c) Lateral Branch Fitting

Fig. 127.4.8(E) Some Acceptable Details for Integrally Reinforced Outlet Fittings (Cont'd)

GENERAL NOTES:

- (a) Welds shall be in accordance with para. 127.4.8(C).
- (b) Weld attachment details for branch fittings that do not match the schedule or weight designation of the run pipe as defined by MSS SP-97 Table 1 shall be designed to meet the requirements in paras. 104.3.1 and 104.7.2.
- (c) The stress intensification factors as required by paras. 104.8 and 119.7.3, for the fittings represented by drawings (b-1), (b-2), (c-1), and (c-2), should be obtained from the fitting manufacturer.

NOTES:

- (1) When the fitting manufacturer has not provided a visible scribe line on the branch fitting, the weld line shall be the edge of the first bevel on the branch fitting adjacent to the run pipe.
- (2) The minimum cover weld throat thickness, t_c , applies when the angle between the branch fitting groove weld face and the run pipe surface is less than 135 deg. For areas where the angle between the groove weld face and the run pipe surface is 135 deg or greater, the cover weld may transition to nothing.
- (3) Cover weld shall provide a smooth transition to the run pipe.
- (4) t_{nb} shall be measured at the plane that passes through the longitudinal centerline of the run pipe and the centerline of the branch fitting. When t_{nb} in the crotch area does not equal t_{nb} in the heel area, the thicker of the two shall govern in determining the heat treatment in accordance with para. 132.4, and in determining the nondestructive examination in accordance with Table 136.4.

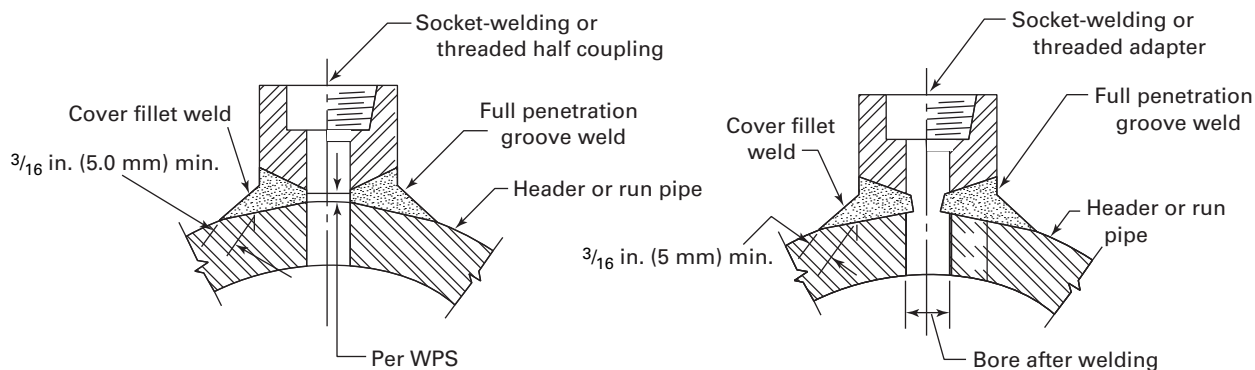
(16) Fig. 127.4.8(F) Typical Full Penetration Weld Branch Connections for NPS 3 (DN 80) and Smaller Half Couplings or Adapters

(a) Branch Connection Using ASME B16.11 Forged Steel Socket-Welding or Threaded Half Coupling [See Note (1)]

(b) Branch Connection Using Forged Steel Socket-Welding or Threaded Adapter for Pressure and Temperature Conditions Greater Than Permitted for ASME B16.11 Forged Steel Fittings

NOTE:

- (1) Refer to para. 104.3.1(C.2) for branch connections not requiring reinforcement calculations.

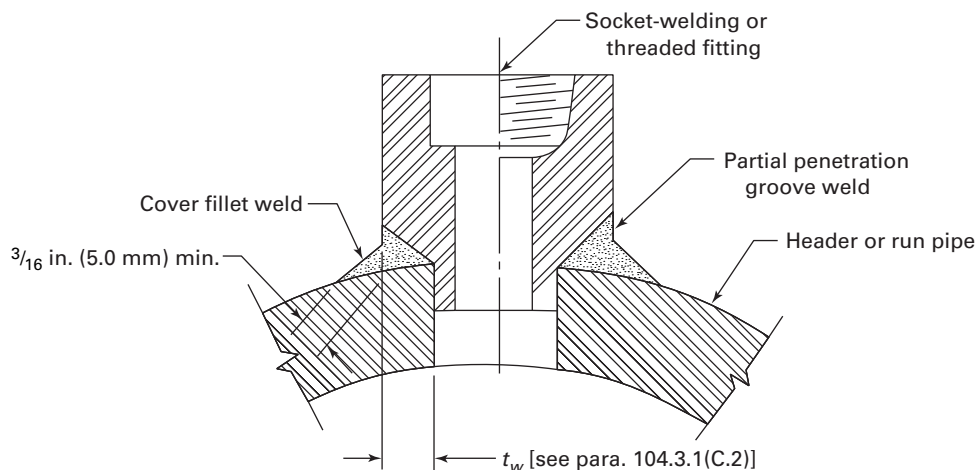
Fig. 127.4.8(G) Typical Partial Penetration Weld Branch Connection for NPS 2 (DN 50) and Smaller Fittings (16)

para. 104. The cover fillet welds shall have a minimum throat dimension not less than that shown in Fig. 127.4.8(E) or Fig. 127.4.8(F), as applicable.

(D) In branch connections having reinforcement pads or saddles, the reinforcement shall be attached by welds at the outer edge and at the branch periphery as follows:

(D.1) If the weld joining the added reinforcement to the branch is a full penetration groove weld, it shall be finished with a cover fillet weld having a minimum throat dimension not less than t_c ; the weld at the outer edge, joining the added reinforcement to the run, shall be a fillet weld with a minimum throat dimension of $0.5t_{nr}$.

(D.2) If the weld joining the added reinforcement to the branch is a fillet weld, the throat dimension shall not be less than $0.7t_{min}$. The weld at the outer edge joining the outer reinforcement to the run shall also be a fillet weld with a minimum throat dimension of $0.5t_{nr}$.

(E) When rings or saddles are used, a vent hole shall be provided (at the side and not at the crotch) in the ring or saddle to reveal leakage in the weld between branch and main run and to provide venting during welding and heat treating operations. Rings or saddles may be made in more than one piece if the joints between the pieces have strength equivalent to ring or saddle parent metal and if each piece is provided with a vent hole. A good fit shall be provided between reinforcing rings or saddles and the parts to which they are attached.

(F) Branch connections NPS 2 (DN 50) and smaller that do not require reinforcements (see para. 104.3) may be constructed as shown in Fig. 127.4.8(G). The groove welds shall be finished with cover fillet welds with a minimum throat dimension not less than that shown in Fig. 127.4.8(G). This construction shall not be used at design temperatures greater than 750°F (400°C) nor at design pressures greater than 1,025 psi (7 100 kPa).

127.4.9 Attachment Welds. Structural attachments may be made by complete penetration, partial penetration, or fillet welds.

Low-energy capacitor discharge welding may be used for welding temporary attachments (e.g., thermocouples) and permanent nonstructural attachments without preheat above 50°F (10°C) or subsequent postweld heat treatment on P-No. 1 through P-No. 5B and P-No. 15E materials, provided that the following requirements are met:

(A) A Welding Procedure Specification is prepared, describing the low-energy capacitor discharge equipment, the combination of materials to be joined, and the technique of application; qualification of the welding procedure is not required.

(B) The energy output of the welding process is limited to 125 W-sec.

(C) For P-No. 5A, P-No. 5B, and P-No. 15E materials, the maximum carbon content of the material is 0.15%.

(D) After temporary attachments are removed, the areas shall be examined in accordance with para. 136.4.

127.4.10 Heat Treatment. Preheat and postweld heat treatment for welds shall be in accordance with para. 131 or 132 as applicable, except as exempted in para. 127.4.9. (16)

127.4.11 Repair Welding

(A) *Defect Removal.* All defects in welds or base materials requiring repair shall be removed by flame or arc gouging, grinding, chipping, or machining. Preheating may be required for flame or arc gouging on certain alloy materials of the air hardening type in order to prevent surface checking or cracking adjacent to the flame or arc gouged surface. When a defect is removed but welding repair is unnecessary, the surface shall be

contoured to eliminate any sharp notches or corners. The contoured surface shall be reinspected by the same means originally used for locating the defect.

(B) *Repair Welds.* Repair welds shall be made in accordance with a WPS using qualified welders or welding operators (see para. 127.5), recognizing that the cavity to be repair welded may differ in contour and dimension from a normal joint preparation and may present different restraint conditions. The types, extent, and methods of examination shall be in accordance with Table 136.4. For repairs to welds the minimum examination shall be the same method that revealed the defect in the original weld. For repairs to base material, the minimum examination shall be the same as required for butt welds.

127.5 Qualification

127.5.1 General. Qualification of the WPS to be used, and of the performance of welders and welding operators, is required, and shall comply with the requirements of the ASME Boiler and Pressure Vessel Code (Section IX) except as modified herein.

Certain materials listed in Mandatory Appendix A do not appear in ASME Section IX P-Number groups. Where these materials have been assigned P-Numbers in Mandatory Appendix A, they may be welded under this Code for nonboiler external piping only without separate qualification as if they were listed in ASME Section IX.

127.5.2 Welding Responsibility. Each employer (see para. 100.2) shall be responsible for the welding performed by his/her organization and the performance of welders or welding operators employed by that organization.

127.5.3 Qualification Responsibility

(A) *Procedures.* Each employer shall be responsible for qualifying any WPS that he/she intends to have used by personnel of his/her organization. However, to avoid duplication of effort, and subject to approval of the owner, a WPS qualified by a technically competent group or agency may be used

(A.1) if the group or agency qualifying the WPS meets all of the procedure qualification requirements of this Code

(A.2) if the fabricator accepts the WPS thus qualified

(A.3) if the user of the WPS has qualified at least one welder using the WPS

(A.4) if the user of the WPS assumes specific responsibility for the procedure qualification work done for him/her by signing the records required by para. 127.6

All four of the above conditions shall be met before a WPS thus qualified may be used.

(B) *Welders and Welding Operators.* Each employer shall be responsible for qualifying all the welders and welding operators employed by him/her.

However, to avoid duplication of effort, he/she may accept a Welder/Welding Operator Performance Qualification (WPQ) made by a previous employer (subject to the approval of the owner or his/her agent) on piping using the same or an equivalent procedure wherein the essential variables are within the limits established in Section IX, ASME Boiler and Pressure Vessel Code. An employer accepting such qualification tests by a previous employer shall obtain a copy of the original WPQ, showing the name of the employer by whom the welders or welding operators were qualified, the dates of such qualification, and evidence that the welder or welding operator has maintained qualification in accordance with QW-322 of Section IX, ASME Boiler and Pressure Vessel Code. The evidence of process usage to maintain continuity may be obtained from employers other than the original qualifying employer. The employer shall then prepare and sign the record required in para. 127.6 accepting responsibility for the ability of the welder or welding operator.

127.5.4 Standard Welding Procedure Specifications. Standard Welding Procedure Specifications published by the American Welding Society and listed in Mandatory Appendix E of Section IX of the ASME Boiler and Pressure Vessel Code are permitted for Code construction within the limitations established by Article V of ASME Section IX.

127.6 Welding Records

The employer shall maintain a record (WPS and/or WPQ) signed by him/her, and available to the purchaser or his/her agent and the inspector, of the WPSs used and the welders and/or welding operators employed by him/her, showing the date and results of procedure and performance qualification.

The WPQ shall also show the identification symbol assigned to the welder or welding operator employed by him/her, and the employer shall use this symbol to identify the welding performed by the welder or welding operator. This may be accomplished by the application of the symbol on the weld joint in a manner specified by the employer. Alternatively, the employer shall maintain records that identify the weld(s) made by the welder or welding operator.

128 BRAZING AND SOLDERING

128.1 General

128.1.1 The brazing processes that are to be used under this part of the Code shall meet all the test requirements of Section IX of the ASME Boiler and Pressure Vessel Code.

128.1.2 Soldering. Solderers shall follow the procedure in ASTM B828, Standard Practice for Making Capillary Joints by Soldering of Copper and Copper Alloy Tube and Fittings.

128.2 Materials

128.2.1 Filler Metal. The brazing alloy or solder shall melt and flow freely within the specified or desired temperature range and, in conjunction with a suitable flux or controlled atmosphere, shall wet and adhere to the surfaces to be joined.

128.2.2 Flux. A flux that is fluid and chemically active at brazing or soldering temperature shall be used when necessary to eliminate oxidation of the filler metal and the surfaces to be joined, and to promote free flow of the brazing alloy or solder.

128.3 Preparation

128.3.1 Surface Preparation. The surfaces to be brazed or soldered shall be clean and free from grease, oxides, paint, scale, dirt, or other material that is detrimental to brazing. A suitable chemical or mechanical cleaning method shall be used if necessary to provide a clean wettable surface.

128.3.2 Joint Clearance. The clearance between surfaces to be joined by brazing or soldering shall be no larger than is necessary to allow complete capillary distribution of the brazing alloy or solder.

128.4 Procedure

128.4.1 General

(A) Qualification of the brazing procedures to be used and of the performance of the brazer and brazing operators is required and shall comply with the requirements of para. 128.5.

(B) No brazing shall be done if there is impingement of rain, snow, sleet, or high wind on the area to be brazed.

128.4.2 Heating. To minimize oxidation, the joint shall be brought to brazing or soldering temperature in as short a time as possible without localized underheating or overheating.

128.4.3 Flux Removal. Residual flux shall be removed if detrimental.

128.5 Brazing Qualification

128.5.1 General. The qualification of the brazing-procedure and of the performance of brazers and brazing operators shall be in accordance with the requirements of Part QB, Section IX, ASME Boiler and Pressure Vessel Code, except as modified herein.

128.5.2 Brazing Responsibility. Each employer (see para. 100.2) shall be responsible for the brazing performed by his/her organization and the performance of

brazers or brazing operators employed by that organization.

128.5.3 Qualification Responsibility

(A) *Procedures.* Each employer shall be responsible for qualifying any Brazing Procedure Specification (BPS) that he/she intends to have used by personnel of his/her organization. However, to avoid duplication of effort, and subject to approval of the owner, a BPS qualified by a technically competent group or agency may be used

(A.1) if the group or agency qualifying the procedures meets all of the procedure qualification requirements of this Code

(A.2) if the fabricator accepts the procedure thus qualified

(A.3) if the user of the procedure has qualified at least one brazer using the BPS

(A.4) if the user of the procedure assumes specific responsibility for the procedure qualification work done by him/her by signing the records required by para. 128.6

All four of the above conditions shall be met before a procedure thus qualified may be used.

(B) *Brazers and Brazing Operators.* Each employer shall be responsible for qualifying all the brazers and brazing operators employed by him/her.

However, to avoid duplication of effort, he/she may accept a Brazer/Brazing Operator Performance Qualification (BPQ) made by a previous employer (subject to the approval of the owner or his/her agent) on piping using the same or an equivalent procedure wherein the essential variables are within the limits established in Section IX, ASME Boiler and Pressure Vessel Code. An employer accepting such qualification tests by a previous employer shall obtain a copy (from the previous employer) of the BPQ, showing the name of the employer by whom the brazers or brazing operators were qualified, the dates of such qualification, and the date the brazer last brazed pressure piping components under such qualification. The employer shall then prepare and sign the record required in para. 128.6 accepting responsibility for the ability of the brazer or brazing operator.

128.6 Brazing Records

The employer shall maintain a record signed by him/her and available to the purchaser or his/her agent and the inspector, showing the date and results of procedure and performance qualification.

The BPQ shall also show the identification symbol assigned to the brazer or brazing operator employed by him/her, and the employer shall use this symbol to identify the brazing performed by the brazer or brazing operator. This may be accomplished by the application of the symbol on the braze joint in a manner specified by the employer. Alternatively, the employer shall maintain

Table 129.3.1 Approximate Lower Critical Temperatures

Material	Approximate Lower Critical Temperature, °F (°C) [Note (1)]
Carbon steel (P-No. 1)	1,340 (725)
Carbon-molybdenum steel (P-No. 3)	1,350 (730)
1Cr-½Mo (P-No. 4, Gr. No. 1)	1,375 (745)
1¼Cr-½Mo (P-No. 4, Gr. No. 1)	1,430 (775)
2¼Cr-1Mo, 3Cr-1Mo (P-No. 5A)	1,480 (805)
5Cr-½Mo (P-No. 5B, Gr. No. 1)	1,505 (820)
9Cr	1,475 (800)
9Cr-1Mo-V, 9Cr-2W (P-No. 15E)	1,470 (800)

NOTE:

- (1) These values are intended for guidance only. The user may apply values obtained for the specific material in lieu of these values.

records that identify the braze joints(s) made by the brazer or brazing operator.

129 BENDING AND FORMING**129.1 Bending**

Pipe may be bent by any hot or cold method and to any radius that will result in a bend surface free of cracks. Such bends shall meet the design requirements of para. 102.4.5 with regard to minimum wall thickness. Where limits on flattening and buckling are not specified by design, as delineated in para. 104.2.1, manufacturing limits of PFI ES-24 shall be met. When defaulting to PFI ES-24, mutual agreement between purchaser and fabricator beyond the stated manufacturing limits shall not be allowed without the approval of the designer.

The use of bends designed as creased or corrugated is not prohibited.

129.2 Forming

Piping components may be formed (swedging, lapping, or upsetting of pipe ends, extrusion of necks, etc.) by any suitable hot or cold working method, provided such processes result in formed surfaces that are uniform and free of cracks or other defects, as determined by method of inspection specified in the design.

129.3 Heat Treatment of Bends and Formed Components

129.3.1 Except for creep strength enhanced ferritic steels (P-No. 15E), hot bending or hot forming is performed at a temperature equal to or above $T_{crit} - 100^\circ\text{F}$ (56°C), where T_{crit} is the lower critical temperature of the material. Cold bending or cold forming is performed at a temperature below $T_{crit} - 100^\circ\text{F}$ (56°C). (See Table 129.3.1 for lower critical temperatures.) For creep

strength enhanced ferritic steels (P-No. 15E), hot bending or hot forming is performed at a temperature equal to or above $1,300^\circ\text{F}$ (705°C). Cold bending or cold forming is performed at a temperature below $1,300^\circ\text{F}$ (705°C).

129.3.2 A postbending or postforming heat treatment at the time and temperature cycles listed for post-weld heat treatment in Table 132 is required on all carbon steel (P-No. 1) materials with a nominal wall thickness in excess of 0.75 in. (19.0 mm) unless the bending or forming operations are performed and completed at temperatures of $1,650^\circ\text{F}$ (900°C) or greater.

129.3.3 A postforming or postbending heat treatment as defined below is required for all ferritic alloy steel (excluding P-No. 1 and P-No. 15E) materials with a nominal pipe size 4 in. (DN 100) and larger or with a nominal thickness of 0.50 in. (12.7 mm) or greater. (16)

(A) If hot bending or hot forming is performed, the material shall receive a full anneal, normalization and temper, or tempering heat treatment as specified by the designer.

(B) If cold bending or cold forming is performed, a heat treatment is required at the time and temperature cycle listed for the material in Table 132.

129.3.3.1 Creep strength enhanced ferritic steel (P-No. 15E) materials subject to forming or bending shall be heat treated in accordance with the following rules. When the material is cold formed or cold bent, cold forming strains shall be calculated in accordance with para. 129.3.4.1 or para. 129.3.4.2. (16)

(A) If hot bending or hot forming is performed, and for all cold swages, flares, or upsets, normalizing and tempering of the material is required in accordance with the requirements in the base material specification.

(B) If cold bending or cold forming is performed, the material shall be heat treated as listed in Table 129.3.3.1.

129.3.3.2 For materials with less than or equal to 5% strain or design temperatures less than $1,000^\circ\text{F}$ (540°C), heat treatment is neither required nor prohibited.

129.3.4 Postbending or postforming heat treatment of austenitic materials shall be performed as follows:

129.3.4.1 Cold-formed areas of components manufactured of austenitic alloys shall be heat treated after forming if they exceed both the design temperatures and forming strains shown in Table 129.3.4.1. Forming strains shall be calculated as follows:

(A) For cylinders formed from plate

$$\% \text{ strain} = 50t_n/R_f(1 - R_f/R_g)$$

(B) For spherical or dished heads formed from plate

$$\% \text{ strain} = 75t_n/R_f(1 - R_f/R_g)$$

Table 129.3.3.1 Post Cold-Forming Strain Limits and Heat-Treatment Requirements

(16)

Grade	UNS Number	Limitations in Lower Temperature Range				And Forming Strains	Limitations in Higher Temperature Range			Required Heat Treatment When Design Temperature and Forming Strain Limits Are Exceeded
		For Design Temperature					For Design Temperature Exceeding			
		Exceeding		But Less Than or Equal to			Exceeding		And Forming Strains	
°F	°C	°F	°C	°F	°C					
91	K90901	1,000	540	1,115	600	>25%	1,115	600	>20%	Normalize and temper [Note (1)]
		1,000	540	1,115	600	>5% to ≤25%	1,115	600	>5% to ≤20%	Postbend heat treatment [Notes (2), (3), and (4)]

GENERAL NOTE: The limits shown are for pipe and tube formed from plates, spherical or dished heads formed from plate, and tube and pipe bends. The forming strain limits tabulated in this Table shall be divided by two if para. 129.3.4.2 is applied.

NOTES:

- (1) Normalization and tempering shall be performed in accordance with the requirements in the base material specification, and shall not be performed locally. The material shall either be heat treated in its entirety, or the cold-strained area (including the transition to the unstrained portion) shall be cut away from the balance of the tube or component and heat treated separately or replaced.
- (2) Postbend heat treatments shall be performed at 1,350°F to 1,425°F (730°C to 775°C) for 1 hr/in. (1 h/25 mm) or 30 min minimum. Alternatively, a normalization and temper in accordance with the requirements in the base material specification may be performed.
- (3) For materials with greater than 5% strain but less than or equal to 25% strain, with design temperatures less than or equal to 1,115°F (600°C), if a portion of the component is heated above the heat-treatment temperature allowed above, one of the following actions shall be performed:
 - (a) The component in its entirety must be renormalized and tempered.
 - (b) For BEP piping only, the allowable stress shall be that for Grade 9 material (i.e., SA-213 T9, SA-335 P9, or equivalent product specification) at the design temperature, provided that the portion of the component that was heated to a temperature exceeding the maximum holding temperature is subjected to a final heat treatment within the temperature range and for the time required in Note (2) above. The use of this provision shall be noted on the Manufacturer's Data Report.
- (4) If a longitudinal weld is made to a portion of the material that is cold strained, that portion shall be normalized and tempered prior to or following welding. This normalizing and tempering shall not be performed locally.

(C) For tube and pipe bends

$$\% \text{ strain} = 100r_{od}/R$$

where

- R = centerline radius of bend
 R_f = mean radius after forming
 R_g = original mean radius (equal to infinity for a flat plate)
 r_{od} = nominal outside radius of pipe or tube
 t_n = nominal thickness of the plate, pipe, or tube before forming

129.3.4.2 When forming strains cannot be calculated as shown in para. 129.3.4.1, the manufacturer shall have the responsibility to determine the maximum forming strain.

129.3.4.3 For flares, swages, or upsets, heat treatment in accordance with Table 129.3.4.1 shall apply, regardless of the amount of strain, unless the finishing forming temperature is equal to or greater than the minimum heat treatment temperature for a given grade or UNS number material, provided the requirements of para. 129.3.4.5 are met.

129.3.4.4 Heat treatment, in accordance with Table 129.3.4.1, shall not be required if the finishing

forming temperature is equal to or greater than the minimum heat treatment temperature for a given grade or UNS number material, provided the requirements of para. 129.3.4.5 are met.

129.3.4.5 The piping components being heat treated shall be held at the temperatures given in Table 129.3.4.1 for 20 min/in. (20 min/25 mm) of thickness, or for 10 min, whichever is greater. (16)

129.3.4.6 Postbending or postforming heat treatment of materials not identified in Table 129.3.4.1 is neither required nor prohibited. If a postbending or postforming heat treatment is to be performed, the designer shall fully describe the procedure to be used.

129.3.5 For ASTM A335 P36 and ASTM A182 F36, after either cold bending to strains in excess of 5% or any hot bending of this material, the full length of the component shall be heat treated in accordance with the requirements specified in the material specification.

129.3.6 Postbending or postforming heat treatment of other materials is neither required nor prohibited. If a postbending or postforming heat treatment is to be performed, the designer shall fully describe the procedure to be used.

(16)

**Table 129.3.4.1
Post Cold-Forming Strain Limits and Heat-Treatment Requirements**

Grade	UNS Number	Limitations in Lower Temperature Range					Limitations in Higher Temperature Range			Minimum Heat-Treatment Temperature When Design Temperature and Forming Strain Limits Are Exceeded [Notes (1) and (2)]	
		For Design Temperature				And Forming Strains Exceeding	For Design Temperature Exceeding		And Forming Strains Exceeding	°F	°C
		Exceeding		But Less Than or Equal to			°F	°C			
		°F	°C	°F	°C						
304	S30400	1,075	580	1,250	675	20%	1,250	675	10%	1,900	1 040
304H	S30409	1,075	580	1,250	675	20%	1,250	675	10%	1,900	1 040
304N	S30451	1,075	580	1,250	675	15%	1,250	675	10%	1,900	1 040
309S	S30908	1,075	580	1,250	675	20%	1,250	675	10%	2,000	1 095
310H	S31009	1,075	580	1,250	675	20%	1,250	675	10%	2,000	1 095
310S	S31008	1,075	580	1,250	675	20%	1,250	675	10%	2,000	1 095
316	S31600	1,075	580	1,250	675	20%	1,250	675	10%	1,900	1 040
316H	S31609	1,075	580	1,250	675	20%	1,250	675	10%	1,900	1 040
316N	S31651	1,075	580	1,250	675	15%	1,250	675	10%	1,900	1 040
321	S32100	1,000	540	1,250	675	15% [Note (3)]	1,250	675	10%	1,900	1 040
321H	S32109	1,000	540	1,250	675	15% [Note (3)]	1,250	675	10%	2,000	1 095
347	S34700	1,000	540	1,250	675	15%	1,250	675	10%	1,900	1 040
347H	S34709	1,000	540	1,250	675	15%	1,250	675	10%	2,000	1 095
348	S34800	1,000	540	1,250	675	15%	1,250	675	10%	1,900	1 040
348H	S34809	1,000	540	1,250	675	15%	1,250	675	10%	2,000	1 095
600	N06600	1,075	580	1,200	650	20%	1,200	650	10%	1,900	1 040
617	N06617	1,200	650	1,400	760	15%	1,400	760	10%	2,100	1 150
690	N06690	1,075	580	1,200	650	20%	1,200	650	10%	1,900	1 040
800	N08800	1,100	595	1,250	675	15%	1,250	675	10%	1,800	980
800H	N08810	1,100	595	1,250	675	15%	1,250	675	10%	2,050	1 120
...	S30815	1,075	580	1,250	675	15%	1,250	675	10%	1,920	1 050
...	N06022	1,075	580	1,250	675	15%	2,050	1 120

GENERAL NOTE: The limits shown are for pipe and tube formed from plates, spherical or dished heads formed from plate, and pipe and tube bends. When the forming strains cannot be calculated as shown in para. 129.3.4.1, the forming strain limits shall be half those tabulated in this Table (see para. 129.3.4.2).

NOTES:

- (1) Rate of cooling from heat-treatment temperature not subject to specific control limits.
- (2) While minimum heat-treatment temperatures are specified, it is recommended that the heat-treatment temperature range be limited to 150°F (85°C) above that minimum and 250°F (140°C) for 347, 347H, 348, and 348H.
- (3) For simple bends of tubes or pipes whose outside diameter is less than 3.5 in. (89 mm), this limit is 20%.

130 REQUIREMENTS FOR FABRICATING AND ATTACHING PIPE SUPPORTS

130.1 Pipe Supports

Standard pipe hangers and supports shall be fabricated in accordance with the requirements of MSS SP-58. Welders, welding operators, and WPSs shall be qualified in accordance with the requirements of the ASME Boiler and Pressure Vessel Code, Section IX.

130.2 Alternate Pipe Supports

Special hangers, supports, anchors, and guides, not defined as standard types of hanger components in MSS SP-58, shall be welded in accordance with the requirements of para. 127 (para. 132 is not applicable except as required by the weld procedure used) and inspected in accordance with the requirements of para. 136.4.2.

130.3 Pipe Support Welds

Welds attaching hangers, supports, guides, and anchors to the piping system shall conform to the requirements of Chapters V and VI of this Code.

131 WELDING PREHEAT

131.1 Minimum Preheat Requirements

The preheat requirements listed herein are mandatory minimum values.

The base metal temperature for the parts to be welded shall be at or above the minimum temperature specified in Table 131.4.1 in all directions from the point of welding for a distance of the larger of 3 in. (75 mm) or 1.5 times the greater nominal thickness (as defined in para. 132.4.3).

The base metal temperature for tack welds shall be at or above the specified minimum temperature for a distance not less than 1 in. (25 mm) in all directions from the point of welding.

131.2 Different P-Number Materials

When welding two different P-Number materials, the minimum preheat temperature required shall be the higher temperature for the material to be welded as shown in Table 131.4.1.

131.3 Preheat Temperature Verification

(A) The preheat temperature shall be checked by use of temperature-indicating crayons, thermocouple pyrometers, or other suitable methods to ensure that the required preheat temperature is obtained prior to, and uniformly maintained during, the welding operation.

(B) Thermocouples may be temporarily attached directly to pressure-containing parts using the low-energy capacitor discharge method of welding in accordance with the requirements of para. 127.4.9(A).

131.4 Preheat Temperature

131.4.1 The minimum preheat temperature shall be as stated in Table 131.4.1.

131.4.2 Higher minimum preheat temperatures may be required by the WPS or by the Designer.

131.6 Interruption of Welding

131.6.1 After welding commences, the minimum preheat temperature shall be maintained until any required PWHT is performed on P-Nos. 3, 4, 5A, 5B, 6, and 15E, except when all of the following conditions are satisfied:

(A) A minimum of at least $\frac{3}{8}$ in. (10 mm) thickness of weld is deposited or 25% of the welding groove is filled, whichever is less (the weldment shall be sufficiently supported to prevent overstressing the weld if the weldment is to be moved or otherwise loaded). Caution is advised that the surface condition prior to cooling should be smooth and free of sharp discontinuities.

(B) For P-Nos. 3, 4, and 5A materials (with a chromium content of 3.0% maximum), the weld is allowed to cool slowly to room temperature.

(C) For P-No. 5B (with a chromium content greater than 3.0%), P-No. 6, and P-No. 15E materials, the weld is subjected to an adequate intermediate heat treatment with a controlled rate of cooling. The preheat temperature may be reduced to 200°F (95°C) (minimum) for the purpose of root examination without performing an intermediate heat treatment.

(D) After cooling and before welding is resumed, visual examination of the weld shall be performed to assure that no cracks have formed.

(E) Required preheat shall be applied before welding is resumed.

131.6.2 Intermediate heat treatment for P-No. 5B or 15E materials may be omitted entirely when using low-hydrogen electrodes and filler metals classified by the filler metal specification with an optional supplemental diffusible-hydrogen designator of H4 or lower and suitably controlled by maintenance procedures to avoid contamination by hydrogen-producing sources. The surface of the base metal prepared for welding shall be free of contaminants.

132 POSTWELD HEAT TREATMENT

132.1 Minimum PWHT Requirements

132.1.1 Before applying the detailed requirements and exemptions in these paragraphs, satisfactory qualification of the WPS to be used shall be performed in accordance with the essential variables of the ASME Boiler and Pressure Vessel Code, Section IX including the conditions of postweld heat treatment or lack of postweld heat treatment and including other restrictions (16)

Table 131.4.1 Preheat Temperatures

Base Metal P-No. [Note (1)]	Base Metal Group	Greater Material Thickness		Additional Limits	Required Minimum Temperature	
		in.	mm		°F	°C
1	Carbon steel	≤1	≤25	%C > 0.30 [Note (2)]	50	10
		>1	>25	%C ≤ 0.30 [Note (2)]	50	10
		>1	>25	%C > 0.30 [Note (2)]	200	95
3	Alloy steel Cr ≤ ½%	≤½	≤13	SMTS ≤ 65 ksi (450 MPa)	50	10
		>½	>13	SMTS ≤ 65 ksi (450 MPa)	200	95
		All	All	SMTS > 65 ksi (450 MPa)	200	95
4	Alloy steel ½% < Cr ≤ 2%	All	All	None	250	120
5A	Alloy steel	All	All	SMTS ≤ 60 ksi (414 MPa)	300	150
				SMTS > 60 ksi (414 MPa)	400	200
5B	Alloy steel	All	All	SMTS ≤ 60 ksi (414 MPa)	300	150
		All	All	SMTS > 60 ksi (414 MPa)	400	200
		>½	>13	%Cr > 6.0 [Note (2)]	400	200
6	Martensitic stainless steel	All	All	None	400 [Note (3)]	200 [Note (3)]
9A	Nickel alloy steel	All	All	None	250	120
9B	Nickel alloy steel	All	All	None	300	150
10I	27Cr steel	All	All	None	300 [Note (4)]	150 [Note (4)]
15E	9Cr–1Mo–V CSEF steel	All	All	None	400	200
All other materials		None	50	10

GENERAL NOTE: SMTS = specified minimum tensile strength.

NOTES:

- (1) P-Nos. and Group nos. from ASME BPV Code, Section IX, QW/QB-422.
- (2) Composition may be based on ladle or product analysis or per specification limits.
- (3) Maximum interpass temperature 600°F (315°C).
- (4) Maintain interpass temperature between 300°F and 450°F (150°C and 230°C).

listed below. Except as otherwise provided in paras. 127.4.9, 132.2, and 132.3, all welds in materials included in the P-Numbers listed in Table 132 shall be given a postweld heat treatment within the temperature range specified in Table 132. (The range specified in Table 132 may be modified by Table 132.1 for the lower limit and para. 132.2 for the upper limit.) The materials in Table 132 are listed in accordance with the material P-Numbers and Group numbers of ASME BPVC, Section IX, Table QW/QB-422. (Note that the P-Nos. are also listed in Mandatory Appendix A.) Welds of materials not included in Table 132 shall be heat treated in accordance with the WPS. Austenitizing PWHTs may be performed but are required to be addressed within the qualified WPS.

132.1.2 Pressure part welds and attachment welds using ferritic filler metals that have a specified chromium content of more than 3% shall receive a postweld heat treatment. The postweld heat treatment time and temperature range used shall be that shown in Table 132 for a base metal of similar composition.

132.1.3 For ASTM A335 P36 and ASTM A182 F36, postweld heat treatment is mandatory under all conditions. Postweld heat treatment shall be in accordance with Table 132.1.3.

132.2 Mandatory PWHT Requirements

Heat treatment may be accomplished by a suitable heating method that will provide the desired heating

Table 132 Postweld Heat Treatment

P-No. and Group No. (ASME BPV Code, Section IX, QW/QB-420)	Holding Temperature Range, °F (°C) [Note (1)]	Minimum Holding Time at Temperature for Control Thickness [Note (2)]	
		≤2 in. (50 mm)	>2 in. (50 mm)
P-No. 1, Groups 1–3	1,100 to 1,200 (595 to 650)	1 hr/in. (25 mm),	2 hr plus 15 min for each
P-No. 3, Groups 1 and 2	1,100 to 1,200 (595 to 650)	15 min minimum	additional inch (25 mm)
P-No. 4, Groups 1 and 2	1,200 to 1,300 (650 to 705)		over 2 in. (50 mm)
P-No. 5A, Group 1	1,250 to 1,400 (675 to 760)		
P-No. 5B, Group 1	1,250 to 1,400 (675 to 760)		
P-No. 6, Groups 1–3	1,400 to 1,475 (760 to 800)		
P-No. 7, Groups 1 and 2 [Note (3)]	1,350 to 1,425 (730 to 775)		
P-No. 8, Groups 1–4	PWHT not required unless required by WPS		
P-No. 9A, Group 1	1,100 to 1,200 (595 to 650)		
P-No. 9B, Group 1	1,100 to 1,175 (595 to 630)		
P-No. 10H, Group 1	PWHT not required unless required by WPS. If done, see Note (4).		
P-No. 10I, Group 1 [Note (3)]	1,350 to 1,500 (730 to 815)		
P-No. 15E, Group 1 [Note (5)]	1,350 to 1,425 (730 to 775) [Notes (6), (7)]	1 hr/in. (25 mm), 30 min minimum	1 hr/in. (25 mm) up to 5 in. (125 mm) plus 15 min for each addi- tional inch (25 mm) over 5 in. (125 mm)
All other materials	PWHT as required by WPS	Per WPS	Per WPS

GENERAL NOTE: The exemptions for mandatory PWHT are defined in Table 132.2.

NOTES:

- (1) The holding temperature range is further defined in paras. 132.1.1 and 132.2.
- (2) The control thickness is defined in para. 132.4.1.
- (3) Cooling rate shall not be greater than 100°F (55°C) per hour in the range above 1,200°F (650°C), after which the cooling rate shall be sufficiently rapid to prevent embrittlement.
- (4) If PWHT is performed after bending, forming, or welding, it shall be within the following temperature ranges for the specific alloy, followed by rapid cooling:
 - Alloys S31803 and S32205 — 1,870°F to 2,010°F (1 020°C to 1 100°C)
 - Alloy S32550 — 1,900°F to 2,050°F (1 040°C to 1 120°C)
 - Alloy S32750 — 1,880°F to 2,060°F (1 025°C to 1 125°C)
 - All others — 1,800°F to 1,900°F (980°C to 1 040°C)
- (5) See para. 125.1.2(C) for hardness requirements for ASTM A217 Grade C12A castings after PWHT.
- (6) The minimum PWHT holding temperature may be 1,325°F (720°C) for nominal material thicknesses (see para. 132.4.3) ≤ $\frac{1}{2}$ in. (13 mm).
- (7) The Ni+Mn content of the filler metal shall not exceed 1.2% unless specified by the designer, in which case the maximum temperature to be reached during PWHT shall be the A₁ (lower transformation or lower critical temperature) of the filler metal, as determined by analysis and calculation or by test, but not exceeding 1,470°F (800°C). If the 1,470°F (800°C) was not exceeded but the A₁ of the filler metal was exceeded or if the composition of the filler metal is unknown, the weld must be removed and replaced. It shall then be rewelded with compliant filler metal and subjected to a compliant PWHT. If the 1,470°F (800°C) limit was exceeded, the weld and the entire area affected by the PWHT will be removed and, if reused, shall be renormalized and tempered prior to reinstallation.

Table 132.1 Alternate Postweld Heat Treatment Requirements for Carbon and Low Alloy Steels, P-Nos. 1 and 3

Decrease in Specified Minimum Temperature, °F (°C)	Minimum Holding Time at Decreased Temperature, hr [Note (1)]
50 (30)	2
100 (55)	4
150 (85) [Note (2)]	10
200 (110) [Note (2)]	20

NOTES:

- (1) Times shown apply to thicknesses ≤1 in. (25 mm). Add 15 min/in. (25 mm) of thickness for control thicknesses >1 in. (25 mm) (see para. 132.4).
- (2) A decrease >100°F (55°C) below the minimum specified temperature is allowable only for P-No. 1, Groups 1 and 2 materials.

Table 132.1.3 Postweld Heat Treatment of P36/F36

Class	Holding Temperature, °F (°C)	Holding Time
1	1,100–1,200 (595–650)	2 in. (50 mm) and less thickness: 1 hr/in. (25 mm), 15 min minimum Over 2 in. (50 mm): add 15 min for each additional 1 in. (25 mm) of thickness
2	1,000–1,150 (540–620)	1 hr/in. (25 mm), ½ hr minimum

and cooling rates, the required metal temperature, temperature uniformity, and temperature control.

(A) The upper limit of the PWHT temperature range in Table 132 is a recommended value that may be exceeded provided the actual temperature does not exceed the lower critical temperature of either material (see Table 129.3.1).

(B) When parts of two different P-Numbers are joined by welding, the postweld heat treatment shall be that specified for the material requiring the higher PWHT temperature. When a nonpressure part is welded to a pressure part and PWHT is required for either part, the maximum PWHT temperature shall not exceed the maximum temperature acceptable for the pressure retaining part.

(C) Caution is necessary to preclude metallurgical damage to some materials or welds not intended or qualified to withstand the PWHT temperatures required. The use of material transition joint designs may be required.

(D) The designer may require PWHT even if not mandatory per Table 132 or Table 132.2.

132.3 Exemptions to Mandatory PWHT Requirements

132.3.1 Postweld heat treatment is not required for the following conditions unless required by the qualified WPS or the designer:

- (A) welds in nonferrous materials
- (B) welds exempted in Table 132 or Table 132.2
- (C) welds subject to temperatures above the lower critical temperature (see Table 129.3.1) during fabrication provided the WPS has been qualified with PWHT (see para. 132.1) at the temperature range to be reached during fabrication

132.3.2 The postweld heat treatment exemptions of Table 132.2 may be based on the actual chemical composition as determined by a ladle or product analysis in accordance with the material specification in lieu of the specified or maximum specified chemical composition limits.

132.3.3 Thermocouples may be temporarily attached directly to pressure-containing parts using the capacitor discharge method of welding in accordance with the requirements of para. 127.4.9(A).

132.4 Definition of Thicknesses Governing PWHT

132.4.1 The term *control thicknesses* as used in Table 132, Table 132.2, and Notes is the lesser thickness of (A) or (B) as follows:

- (A) the thickness of the weld
- (B) the thicker of the materials being joined at the weld or the thickness of the pressure-containing material if the weld is attaching a nonpressure-containing material to a pressure-containing material

132.4.2 Thickness of the weld, which is a factor in determining the control thickness, is defined as follows: (16)

- (A) groove welds (girth and longitudinal) — the thicker of the two abutting ends after weld preparation, including I.D. machining

Table 132.2 Exemptions to Mandatory Postweld Heat Treatment

P-No. and Group No. (ASME BPV Code, Section IX, QW/QB-420) [Note (1)]	Control Thickness, in. (mm) [Note (2)]	Type of Weld	Additional Limitations Required for Exemption From PWHT [Notes (3)–(5)]
P-No. 1, all Groups	All	All	A preheat of 200°F (95°C) is applied prior to welding on any nominal material thickness >1 in. (25 mm) Multiple layer welds are used when the nominal material thickness > $\frac{3}{16}$ in. (5 mm) See Note (6)
P-No. 3, Groups 1 and 2	$\leq \frac{5}{8}$ in. (16 mm)	All	A preheat of 200°F (95°C) is applied prior to welding on any nominal material thickness > $\frac{5}{8}$ in. (16 mm) Specified carbon content of the base materials $\leq 0.25\%$ Multiple layer welds are used when the nominal material thickness > $\frac{3}{16}$ in. (5 mm) See Note (6)
P-No. 4, Group 1	$\leq \frac{5}{8}$ in. (16 mm)	Groove	The mandatory preheat has been applied Specified carbon content of the base materials $\leq 0.15\%$ Multiple layer welds are used when the nominal material thickness > $\frac{3}{16}$ in. (5 mm) See Note (6)
	$\leq \frac{5}{8}$ in. (16 mm), except the thickness of a socket weld fitting or flange need not be considered	Socket and fillet welds	The mandatory preheat has been applied The throat thickness of the fillet weld or the socket weld is $\leq \frac{1}{2}$ in. (13 mm) Specified carbon content of the pipe material $\leq 0.15\%$ Nominal material thickness of the pipe $\leq \frac{5}{8}$ in. (16 mm) Multiple layer welds are used when the nominal material thickness > $\frac{3}{16}$ in. (5 mm) See Note (6)
	$\leq \frac{5}{8}$ in. (16 mm)	Seal welds and non-load-carrying attachments [Note (7)]	The mandatory preheat has been applied Multiple layer welds are used when the nominal material thickness > $\frac{3}{16}$ in. (5 mm) See Note (6)

Table 132.2 Exemptions to Mandatory Postweld Heat Treatment (Cont'd)

P-No. and Group No. (ASME BPV Code, Section IX, QW/QB-420) [Note (1)]	Control Thickness, in. (mm) [Note (2)]	Type of Weld	Additional Limitations Required for Exemption From PWHT [Notes (3)–(5)]
P-No. 5A, Group 1	$\leq \frac{5}{8}$ in. (16 mm)	Groove	The mandatory preheat has been applied Specified carbon content of the base materials $\leq 0.15\%$ Multiple layer welds are used when the nominal material thickness $> \frac{3}{16}$ in. (5 mm) See Note (6)
	$\leq \frac{5}{8}$ in. (16 mm), except the thickness of a socket weld fitting or flange need not be considered	Socket and fillet welds	The mandatory preheat has been applied The throat thickness of the fillet weld or the socket weld is $\leq \frac{1}{2}$ in. (13 mm) Specified carbon content of the pipe material $\leq 0.15\%$ The nominal thickness of the pipe is $\leq \frac{5}{8}$ in. (16 mm) Multiple layer welds are used when the nominal material thickness $> \frac{3}{16}$ in. (5 mm) See Note (6)
	$\leq \frac{5}{8}$ in. (16 mm)	Seal welds and non-load-carrying attachments [Note (7)]	The mandatory preheat has been applied Multiple layer welds are used when the nominal material thickness $> \frac{3}{16}$ in. (5 mm) See Note (6)
P-No. 5B, Group 1	No exemptions to PWHT		...
P-No. 6, Groups 1–3	All	All	Specified carbon content of the base materials $\leq 0.08\%$ Nominal material thickness $\leq \frac{3}{8}$ in. (10 mm) The weld filler metal is A-No. 8, A-No. 9, or F-No. 43 composition See Note (8)
P-No. 7, Group 1	All	All	Specified carbon content of the base materials $\leq 0.08\%$ Nominal material thickness $\leq \frac{3}{8}$ in. (10 mm) The weld filler metal is A-No. 8, A-No. 9, or F-No. 43 composition See Note (8)
P-No. 7, Group 2	No exemptions to PWHT		...
P-No. 8, all Groups	All	All	PWHT neither required nor prohibited

Table 132.2 Exemptions to Mandatory Postweld Heat Treatment (Cont'd)

P-No. and Group No. (ASME BPV Code, Section IX, QW/QB-420) [Note (1)]	Control Thickness, in. (mm) [Note (2)]	Type of Weld	Additional Limitations Required for Exemption From PWHT [Notes (3)–(5)]
P-No. 9A, Group 1	All	All	Specified carbon content of the pipe material $\leq 0.15\%$ Nominal material thickness $\leq \frac{1}{2}$ in. (13 mm) The mandatory preheat has been applied
P-No. 9B, Group 1	All	All	Nominal material thickness $\leq \frac{5}{8}$ in. (16 mm) and the WPS has been qualified using a material of equal or greater thickness than used in the production weld
P-No. 10H, Group 1	All	All	PWHT neither required nor prohibited
P-No. 10I, Group 1	All	All	PWHT neither required nor prohibited for nominal material thickness $\leq \frac{1}{2}$ in. (13 mm)
P-No. 15E	No exemptions to PWHT		...

NOTES:

- (1) If differences with the P-No. listed in Mandatory Appendix A are found, the P-No. listed in ASME BPV Code, Section IX, Table QW/QB-422 applies.
- (2) The control thickness is defined in para. 132.4.1.
- (3) The nominal material thickness is defined in para. 132.4.3.
- (4) No exemptions are permitted for PWHTs required by the designer or the WPS.
- (5) Additional exemptions for welds made in accordance with para. 127.4.9 may be taken for the materials addressed.
- (6) Single layer or single pass welds may be exempted from PWHT, provided the WPS has been qualified using single pass welds with $\pm 10\%$ heat input and that all other conditions for exemption are met.
- (7) Non-load-carrying attachments are defined as items where no pressure loads or significant mechanical loads are transmitted through the attachment to the pipe or pressure-containing material.
- (8) The A-Nos. and F-Nos. are found in ASME BPV Code, Section IX, Tables QW-442 and QW-432, respectively.

(B) fillet welds — the throat thickness of the weld
(C) partial penetration welds — the depth of the weld groove

(D) material repair welds — the depth of the cavity to be repaired

(E) branch welds — the weld thickness is the dimension existing in the plane intersecting the longitudinal axes and is calculated as indicated for each detail using

$$t_c = \text{the smaller of } \frac{1}{4} \text{ in. (6 mm) or } 0.7t_{nb}$$

(E.1) for welds described in Fig. 127.4.8(D):

Detail (a)

$$\text{weld thickness} = t_{nb} + t_c$$

Detail (b)

$$\text{weld thickness} = t_{nh} + t_c$$

Detail (c)

$$\text{weld thickness} = \text{greater of } t_{nr} + t_c \text{ or } t_{nb} + t_c$$

Detail (d)

$$\text{weld thickness} = t_{nh} + t_{nr} + t_c$$

Detail (e)

$$\text{weld thickness} = t_{nb} + t_c$$

(E.2) for welds described in Fig. 127.4.8(E):

$$\text{weld thickness} = t_{nb} + t_c$$

(E.3) for welds described in Fig. 127.4.8(F) and Fig. 127.4.8(G):

$$\text{weld thickness} = \text{depth of groove weld} \\ + \text{throat thickness of cover fillet}$$

132.4.3 The term *nominal material thickness* as used in Table 132.2 is the thicker of the pressure-retaining materials being joined at the weld.

132.5 PWHT Heating and Cooling Requirements

Above 600°F (315°C), the rate of heating and cooling shall not exceed 600°F/hr (315°C/h) divided by one-half the maximum thickness of material in inches at the weld, but in no case shall the rate exceed 600°F/hr (315°C/h). (See Table 132 for cooling rate requirements for P-Nos. 7 and 10I materials.)

(16) 132.6 Furnace Heating

(A) Heating an assembly in a furnace should be used when practical; however, the size or shape of the unit or the adverse effect of a desired heat treatment on one or more components where dissimilar materials are involved, may dictate alternative procedures such as heating a section before assembly, or by applying local heating in accordance with para. 132.7.

(B) An assembly may be postweld heat treated in more than one heat in a furnace provided there is at least a 1 ft (300 mm) overlap of the heated sections and the portion of the assembly outside the furnace is shielded so that the temperature gradient is not harmful. This method may not be used for austenitizing heat treatments of ferritic materials.

(C) Direct impingement of flame on the assembly is prohibited.

(D) The furnace shall be calibrated such that the PWHT can be controlled within the required temperature range.

132.7 Local Heating

PWHT may be performed locally by heating a circumferential band around the entire component with the weld located in the approximate center of the band. The width of the band heated to the specified temperature range shall be at least three times the wall thickness at the weld of the thickest part being joined. For nozzle and attachment weld, the width of the band heated to the specified temperature range shall extend beyond the nozzle weld or attachment weld on each side at least two times the run pipe thickness and shall extend completely around the run pipe. Guidance for the placement of thermocouples on circumferential butt welds is provided in AWS D10.10, Sections 5, 6, and 8. Special consideration shall be given to the placement of thermocouples when heating welds adjacent to large heat sinks such as valves or fittings, or when joining parts of different thicknesses. No part of the materials subjected to the heat source shall exceed the lower critical temperature of the material. Particular care must be exercised when the applicable PWHT temperature is close to the material's lower critical temperature, such as for P-No. 15E materials or when materials of different P-Nos. are being joined. This method may not be used for austenitizing heat treatments.

133 STAMPING

Stamping, if used, shall be performed by a method that will not result in sharp discontinuities. In no case shall stamping infringe on the minimum wall thickness or result in dimpling or denting of the material being stamped.

CAUTIONARY NOTE: Detrimental effects can result from stamping of material that will be in operation under long-term creep or creep fatigue conditions.

135 ASSEMBLY

135.1 General

The assembly of the various piping components, whether done in a shop or as field erection, shall be done so that the completely erected piping conforms with the requirements of the engineering design.

135.2 Alignment

135.2.1 Equipment Connections. When making connections to equipment, such as pumps or turbines or other piping components that are sensitive to externally induced loading, forcing the piping into alignment is prohibited if this action introduces end reactions that exceed those permitted by design.

135.2.2 Cold Springs. Before assembling joints in piping to be cold sprung, an examination shall be made of guides, supports, and anchors for obstructions that might interfere with the desired movement or result in undesired movement. The gap or overlap of piping prior to assembly shall be checked against the design specifications and corrected if necessary.

135.3 Bolted Flanged Connections

135.3.1 Fit Up. All flanged joints shall be fitted up so that the gasket contact surfaces bear uniformly on the gasket and then shall be made up with relatively uniform bolt stress.

135.3.2 Gasket Compression. When bolting gasketed flange joints, the gasket shall be properly compressed in accordance with the design principles applicable to the type of gasket being used.

135.3.3 Cast Iron to Steel Joints. Cast iron to steel flanged joints in accordance with para 108.3 shall be assembled with care to prevent damage to the cast iron flange.

135.3.4 Bolt Engagement. All bolts shall be engaged so that there is visible evidence of complete threading through the nut or threaded attachment.

135.3.5 Nonmetallic Lined Joints. When assembling nonmetallic lined joints, such as plastic lined steel pipe, consideration should be given to maintaining electrical

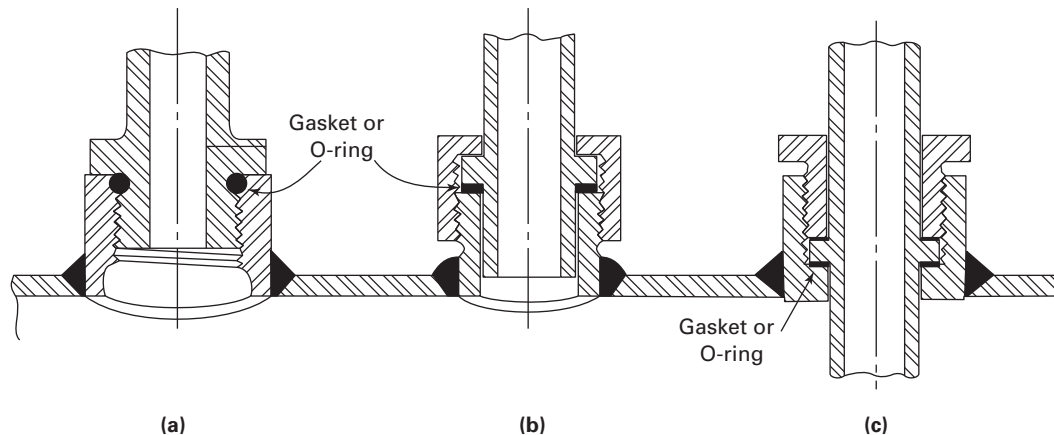
Fig. 135.5.3 Typical Threaded Joints Using Straight Threads

GENERAL NOTE: Threads are ASME B1.1 straight threads.

continuity between flanged pipe sections where required.

135.4 Packed Joints and Caulked Joints

Care shall be used to ensure adequate engagement of joint members. Where packed joints are used to absorb thermal expansion, proper clearance shall be provided at the bottom of the sockets to permit movement.

135.5 Threaded Piping

135.5.1 Thread Compound. Any compound or lubricant used in threaded joints shall be suitable for the service conditions, and shall be compatible with the piping material and the service fluid.

135.5.2 Joints for Seal Welding. Threaded joints that are intended to be seal welded in accordance with para. 127.4.5 *should* be made up without any thread compound.

135.5.3 Joints Using Straight Threads. Some joints using straight threads, with sealing at a surface other than threads, are shown in Fig. 135.5.3. Care shall be used to avoid distorting the seal when incorporating such joints into piping assemblies by welding or brazing.

135.5.4 Backing Off. Backing off threaded joints to allow for alignment is prohibited.

135.6 Tubing Joints

135.6.1 Flared. The sealing surface shall be free of injurious defects before installation.

135.6.2 Flareless and Compression. Flareless and compression joints shall be assembled in accordance with manufacturer's recommendations.

135.7 Ductile Iron Bell End Piping

Assembly of ductile iron pipe, using ANSI/AWWA C111/A21.11 mechanical or push-on joints, shall comply with AWWA C600.

Chapter VI

Inspection, Examination, and Testing

136 INSPECTION AND EXAMINATION

136.1 Inspection

136.1.1 General. Inspection is the responsibility of the owner and may be performed by employees of the owner or a party authorized by the owner, except for the inspections required by para. 136.2.

136.1.2 Verification of Compliance. Prior to initial operation, a piping installation shall be inspected to ensure that the piping has been constructed in accordance with the design, material, fabrication, assembly, examination, and testing requirements of this Code.

(A) For boiler external piping (BEP), the Authorized Inspector shall verify, in accordance with PG-90 of Section I of the Boiler and Pressure Vessel Code, compliance with the requirements of this Code when a Code stamp for BEP is to be applied. The quality control system requirements of Nonmandatory Appendix A, A-301 and A-302, of Section I of the ASME Boiler and Pressure Vessel Code and Mandatory Appendix J of this Code shall apply.

(B) For nonboiler external piping (NBEP), the owner shall ensure that the design and construction documents and the requirements of this Code have been complied with in accordance with the owner's requirements.

136.1.3 Rights of Inspectors. Inspectors shall have access to any place where work concerned with the piping is being performed. This includes manufacture, fabrication, heat treatment, assembly, erection, examination, and testing of the piping. They shall have the right to audit any examination, to inspect the piping using any appropriate examination method required by the engineering design or this Code, and to review all certifications and records necessary to satisfy the owner's responsibility as stated in para. 136.1.1.

(16) **136.1.4 Qualifications of the Owner's Inspector**

(A) The Owner's Inspector shall be designated to perform inspections on behalf of the owner and shall be an employee of the owner, an engineering or scientific organization, or a recognized insurance or inspection company acting as the owner's agent. The Owner's Inspector shall not represent nor be an employee of the piping manufacturer, fabricator, or erector unless the owner is also the manufacturer, fabricator, or erector.

(B) The Owner's Inspector shall meet one of the following requirements:

(B.1) have at least 10 yr of experience in the design, manufacture, erection, fabrication, inspection, or examination of piping systems. Each year of satisfactorily completed work toward an accredited engineering or engineering technology degree shall be considered equivalent to 1 yr of experience, up to 5 yr total.

(B.2) have a professional engineering registration or nationally recognized equivalent with a minimum of 5 yr of experience in the design, manufacturing, erection, fabrication, inspection, or examination of piping systems.

(B.3) be a certified Welding Inspector or a Senior Certified Welding Inspector as defined in AWS QC1, or a nationally recognized equivalent, with a minimum of 5 yr of experience in the design, manufacturing, erection, fabrication, inspection, or examination of piping systems.

(B.4) be an Authorized Piping Inspector as defined in API 570, Piping Inspection Code: In-Service Inspection, Rating, Repair, and Alteration of Piping Systems, with a minimum of 5 yr of experience in the design, manufacturing, erection, fabrication, inspection, or examination of piping systems.

(C) In delegating the performance of inspections, the owner is responsible for determining that a person to whom an inspection function is delegated is qualified to perform that function.

136.2 Inspection and Qualification of Authorized Inspector for Boiler External Piping

136.2.1 Piping for which inspection and stamping is required as determined in accordance with para. 100.1.2(A) shall be inspected during construction and after completion and at the option of the Authorized Inspector at such stages of the work as he/she may designate. For specific requirements see the applicable parts of Section I of the ASME Boiler and Pressure Vessel Code, PG-104 through PG-113. Each manufacturer, fabricator, or assembler is required to arrange for the services of Authorized Inspectors.

136.2.1.1 The inspections required by this Section shall be performed by an Inspector employed by an ASME accredited Authorized Inspection Agency.

136.2.2 Certification by use of the ASME Certification Mark and Designators, and Data Reports,

where required, shall be as per PG-104, PG-105, PG-109, PG-110, PG-111, and PG-112 of Section I of the ASME Boiler and Pressure Vessel Code.

136.3 Examination

136.3.1 General. Examination denotes the functions performed by the manufacturer, fabricator, erector, or a party authorized by the owner that include nondestructive examinations (NDE), such as visual, radiography, ultrasonic, eddy current, liquid penetrant, and magnetic particle methods. The degree of examination and the acceptance standards beyond the requirements of this Code shall be a matter of prior agreement between the manufacturer, fabricator, or erector and the owner.

- (16) **136.3.2 Qualification of NDE Personnel.** Personnel who perform nondestructive examination of welds shall be qualified and certified for each examination method in accordance with a program established by the employer of the personnel being certified, which shall be based on the following minimum requirements:

(A) instruction in the fundamentals of the nondestructive examination method.

(B) on-the-job training to familiarize the NDE personnel with the appearance and interpretation of indications of weld defects. The length of time for such training shall be sufficient to ensure adequate assimilation of the knowledge required.

(C) an eye examination performed at least once each year to determine optical capability of NDE personnel to perform the required examinations.

(D) upon completion of (A) and (B) above, the NDE personnel shall be given an oral or written examination and performance examination by the employer to determine if the NDE personnel are qualified to perform the required examinations and interpretation of results.

(E) certified NDE personnel whose work has not included performance of a specific examination method for a period of 1 yr or more shall be recertified by successfully completing the examination of (D) above and also passing the visual examination of (C) above. Substantial changes in procedures or equipment shall require recertification of the NDE personnel.

As an alternative to the preceding program, the requirements of the ASME Boiler and Pressure Vessel Code, Section V, Article 1 may be used for the qualification of NDE personnel. Personnel qualified to AWS QC1 may be used for the visual examination of welds provided they meet the annual eye examination requirement of (C) above and the J1 visual acuity requirement of Section V, Article 9.

136.4 Examination Methods of Welds

136.4.1 Nondestructive Examination. Nondestructive examinations shall be performed in accordance with the requirements of this Chapter. The types and extent of mandatory examinations for pressure welds and

welds to pressure retaining components are specified in Table 136.4. For welds other than those covered by Table 136.4, only visual examination is required. Welds requiring nondestructive examination shall comply with the applicable acceptance standards for indications as specified in paras. 136.4.2 through 136.4.6. As a guide, the detection capabilities for the examination method are shown in Table 136.4.1. Welds not requiring examination (i.e., RT, UT, MT, or PT) by this Code or the engineering design shall be judged acceptable if they meet the examination requirements of para. 136.4.2 and the pressure test requirements specified in para. 137. NDE for P-Nos. 3, 4, 5A, 5B, and 15E material welds shall be performed after postweld heat treatment unless directed otherwise by engineering design. Required NDE for welds in all other materials may be performed before or after postweld heat treatment.

136.4.2 Visual Examination. Visual examination as defined in para. 100.2 shall be performed in accordance with the requirements described in Section V, Article 9, of the ASME Boiler and Pressure Vessel Code. Visual examinations may be conducted, as necessary, during the fabrication and erection of piping components to provide verification that the design and WPS requirements are being met. In addition, visual examination shall be performed to verify that all completed welds in pipe and piping components comply with the acceptance standards specified in (A) below or with the limitations on imperfections specified in the material specification under which the pipe or component was furnished. (16)

(A) *Acceptance Standards.* The following indications are unacceptable:

(A.1) cracks — external surface.

(A.2) undercut on the surface that is greater than $\frac{1}{32}$ in. (1.0 mm) deep, or encroaches on the minimum required section thickness.

(A.3) undercut on the surface of longitudinal butt welds.

(A.4) weld reinforcement greater than specified in Table 127.4.2.

(A.5) lack of fusion on surface.

(A.6) incomplete penetration (applies only when inside surface is readily accessible).

(A.7) any other linear indications greater than $\frac{3}{16}$ in. (5.0 mm) long.

(A.8) surface porosity with rounded indications having dimensions greater than $\frac{3}{16}$ in. (5.0 mm) or four or more rounded indications separated by $\frac{1}{16}$ in. (2.0 mm) or less edge to edge in any direction. Rounded indications are indications that are circular or elliptical with their length less than three times their width.

136.4.3 Magnetic Particle Examination. Whenever required by this Chapter (see Table 136.4), magnetic particle examination shall be performed in accordance (16)

Table 136.4 Mandatory Minimum Nondestructive Examinations for Pressure Welds or Welds to Pressure-Retaining Components

Type Weld	Piping Design Conditions and Nondestructive Examination		
	Temperatures Over 750°F (400°C) and at All Pressures	Temperatures Between 350°F (175°C) and 750°F (400°C) Inclusive, With All Pressures Over 1,025 psig [7 100 kPa (gage)]	All Others
Butt welds (girth and longitudinal) [Note (1)]	Volumetric examination (RT or UT) for over NPS 2 (DN 50). MT or PT for NPS 2 (DN 50) and less [Note (2)]	Volumetric examination (RT or UT) for over NPS 2 (DN 50) with thickness over $\frac{3}{4}$ in. (19.0 mm). VT for all sizes with thickness $\frac{3}{4}$ in. (19.0 mm) or less	Visual for all sizes and thicknesses
Welded branch connections (size indicated is branch size) [Notes (3), (4), and (5)]	Volumetric examination (RT or UT) for over NPS 4 (DN 100). MT or PT for NPS 4 (DN 100) and less [Note (2)]	Volumetric examination (RT or UT) for branch over NPS 4 (DN 100) and thickness of branch over $\frac{3}{4}$ in. (19.0 mm) MT or PT for branch NPS 4 (DN 100) and less with thickness of branch over $\frac{3}{4}$ in. (19 mm) VT for all sizes with branch thickness $\frac{3}{4}$ in. (19.0 mm) or less	VT for all sizes and thicknesses
Fillet, socket, attachment, and seal welds	PT or MT for all sizes and thicknesses [Note (6)]	VT for all sizes and thicknesses	VT for all sizes and thicknesses

GENERAL NOTES:

- All welds shall be given a visual examination in addition to the type of specific nondestructive examination specified.
- NPS — nominal pipe size; DN — diameter nominal.
- RT — radiographic examination; UT — ultrasonic examination; MT — magnetic particle examination; PT — liquid penetrant examination; VT — visual examination.
- For nondestructive examinations of the pressure retaining component, refer to the standards listed in Table 126.1 or manufacturing specifications.
- Acceptance standards for nondestructive examinations performed are as follows: MT — see para. 136.4.3; PT — see para. 136.4.4; VT — see para. 136.4.2; RT — see para. 136.4.5; UT — see para. 136.4.6.
- All longitudinal welds and spiral welds in pipe intended for sustained operation in the creep range (see paras. 104.1.1 and 123.4, and Table 102.4.7) must receive and pass a 100% volumetric examination (RT or UT) per the applicable material specification or in accordance with para. 136.4.5 or 136.4.6.

NOTES:

- The thickness of butt welds is defined as the thicker of the two abutting ends after end preparation.
- RT may be used as an alternative to PT or MT when it is performed in accordance with para. 136.4.5.
- Volumetric examination (RT or UT) of branch welds shall be performed before any nonintegral reinforcing material is applied.
- In lieu of volumetric examination (RT, UT) of welded branch connections when required above, surface examination (PT, MT) is acceptable and, when used, shall be performed at the lesser of one-half of the weld thickness or each $\frac{1}{2}$ in. (12.5 mm) of weld thickness and all accessible final weld surfaces.
- Branch thickness is t_{nb} as defined in para. 127.4.8, Fig. 127.4.8(D), and Fig. 127.4.8(E).
- Fillet welds not exceeding $\frac{1}{4}$ in. (6 mm) throat thickness which are used for the permanent attachment of nonpressure retaining parts are exempt from the PT or MT requirements of the above Table.

Table 136.4.1 Weld Imperfections Indicated by Various Types of Examination

Imperfection	Visual	Magnetic Particle	Liquid Penetrant	Radiography	Ultrasonic
Crack — surface	X [Note (1)]	X [Note (1)]	X [Note (1)]	X	X
Crack — internal	X	X
Undercut — surface	X [Note (1)]	X [Note (1)]	X [Note (1)]	X	...
Weld reinforcement	X [Note (1)]	X	...
Porosity	X [Notes (1), (2)]	X [Notes (1), (2)]	X [Notes (1), (2)]	X	...
Slag inclusion	X [Note (2)]	X [Note (2)]	X [Note (2)]	X	X
Lack of fusion (on surface)	X [Notes (1), (2)]	X [Notes (1), (2)]	X [Notes (1), (2)]	X	X
Incomplete penetration	X [Note (3)]	X [Note (3)]	X [Note (3)]	X	X

NOTES:

- (1) Applies when the outside surface is accessible for examination and/or when the inside surface is readily accessible.
- (2) Discontinuities are detectable when they are open to the surface.
- (3) Applies *only* when the inside surface is readily accessible.

with the requirements of Section V, Article 7, of the ASME Boiler and Pressure Vessel Code.

(A) Evaluation of Indications

(A.1) Mechanical discontinuities at the surface will be indicated by the retention of the examination medium. All indications are not necessarily defects; however, certain metallurgical discontinuities and magnetic permeability variations may produce similar indications that are not relevant to the detection of unacceptable discontinuities.

(A.2) Any indication that is believed to be nonrelevant shall be reexamined to verify whether or not actual defects are present. Surface conditioning may precede the reexamination. Nonrelevant indications that would mask indications of defects are unacceptable.

(A.3) Relevant indications are those that result from unacceptable mechanical discontinuities. Linear indications are those indications in which the length is more than three times the width. Rounded indications are indications that are circular or elliptical with the length less than three times the width.

(A.4) An indication of a discontinuity may be larger than the discontinuity that causes it; however, the size of the indication and not the size of the discontinuity is the basis of acceptance or rejection.

(B) *Acceptance Standards.* Indications whose major dimensions are greater than $\frac{1}{16}$ in. (2.0 mm) shall be considered relevant. The following relevant indications are unacceptable:

(B.1) any cracks or linear indications

(B.2) rounded indications with dimensions greater than $\frac{3}{16}$ in. (5.0 mm)

(B.3) four or more rounded indications in a line separated by $\frac{1}{16}$ in. (2.0 mm) or less, edge to edge

(B.4) ten or more rounded indications in any 6 in.² (3 870 mm²) of surface with the major dimension of this area not to exceed 6 in. (150 mm) with the area taken in

the most unfavorable location relative to the indications being evaluated

136.4.4 Liquid Penetrant Examination. Whenever required by this Chapter (see Table 136.4), liquid penetrant examination shall be performed in accordance with the requirements of Section V, Article 6, of the ASME Boiler and Pressure Vessel Code. (16)

(A) Evaluation of Indications

(A.1) Mechanical discontinuities at the surface will be indicated by bleeding out of the penetrant; however, localized surface imperfections, such as may occur from machining marks or surface conditions, may produce similar indications that are nonrelevant to the detection of unacceptable discontinuities.

(A.2) Any indication that is believed to be nonrelevant shall be regarded as a defect and shall be reexamined to verify whether or not actual defects are present. Surface conditioning may precede the reexamination. Nonrelevant indications and broad areas of pigmentation that would mask indications of defects are unacceptable.

(A.3) Relevant indications are those that result from mechanical discontinuities. Linear indications are those indications in which the length is more than three times the width. Rounded indications are indications that are circular or elliptical with the length less than three times the width.

(A.4) An indication of a discontinuity may be larger than the discontinuity that causes it; however, the size of the indication and not the size of the discontinuity is the basis of acceptance or rejection.

(B) *Acceptance Standards.* Indications whose major dimensions are greater than $\frac{1}{16}$ in. (2.0 mm) shall be considered relevant. The following relevant indications are unacceptable:

(B.1) any cracks or linear indications

(B.2) rounded indications with dimensions greater than $\frac{3}{16}$ in. (5.0 mm)

(B.3) four or more rounded indications in a line separated by $\frac{1}{16}$ in. (2.0 mm) or less edge to edge

(B.4) ten or more rounded indications in any 6 in.² (3 870 mm²) of surface with the major dimension of this area not to exceed 6 in. (150 mm) with the area taken in the most unfavorable location relative to the indications being evaluated

- (16) **136.4.5 Radiography.** When required by this Chapter (see Table 136.4), radiographic examination shall be performed in accordance with the requirements of Section V, Article 2, of the ASME Boiler and Pressure Vessel Code, except that the requirements of T-274 are to be used as a guide but not for the rejection of radiographs unless the geometrical unsharpness exceeds 0.07 in. (2.0 mm).

(A) *Acceptance Standards.* Welds that are shown by radiography to have any of the following types of discontinuities are unacceptable:

(A.1) any type of crack or zone of incomplete fusion or penetration

(A.2) any other elongated indication that has a length greater than

(A.2.1) $\frac{1}{4}$ in. (6.0 mm) for t up to $\frac{3}{4}$ in. (19.0 mm), inclusive

(A.2.2) $\frac{1}{3}t$ for t from $\frac{3}{4}$ in. (19.0 mm) to $2\frac{1}{4}$ in. (57.0 mm), inclusive

(A.2.3) $\frac{3}{4}$ in. (19.0 mm) for t over $2\frac{1}{4}$ in. (57.0 mm) where t is the thickness of the thinner portion of the weld

NOTE: t referred to in (A.2.1), (A.2.2), and (A.2.3) above pertains to the thickness of the weld being examined; if a weld joins two members having different thickness at the weld, t is the thinner of these two thicknesses.

(A.3) any group of indications in line that have an aggregate length greater than t in a length of $12t$, except where the distance between the successive indications exceeds $6L$ where L is the longest indication in the group

(A.4) porosity in excess of that shown as acceptable in Nonmandatory Appendix A, A-250 of Section I of the ASME Boiler and Pressure Vessel Code

(A.5) root concavity when there is an abrupt change in density, as indicated on the radiograph

- (16) **136.4.6 Ultrasonic Examination.** When required by this Chapter (see Table 136.4), ultrasonic examination (UT) shall be performed in accordance with the requirements of Section V, Article 4, of the ASME Boiler and Pressure Vessel Code and the additional requirements below.

(A) The following criteria shall also be met when performing ultrasonic examinations:

(A.1) The equipment used to perform the examination shall be capable of recording the UT data to facilitate the analysis by a third party and for the repeatability of subsequent examinations, should they be required.

Where physical obstructions prevent the use of systems capable of recording the UT data, manual UT may be used with the approval of the owner.

(A.2) NDE personnel performing and evaluating UT examinations shall be qualified and certified in accordance with their employer's written practice and the requirements of para. 136.3.2 of this Code. Personnel, procedures, and equipment used to collect and analyze UT data shall have demonstrated their ability to perform an acceptable examination using test blocks approved by the owner.

(B) *Acceptance Standards.* Welds that are shown by ultrasonic examination to have discontinuities that produce an indication greater than 20% of the reference level shall be investigated to the extent that ultrasonic examination personnel can determine their shape, identity, and location so that they may evaluate each discontinuity for acceptance in accordance with (B.1) and (B.2) below.

(B.1) Discontinuities evaluated as being cracks, lack of fusion, or incomplete penetration are unacceptable regardless of length.

(B.2) Other discontinuities are unacceptable if the indication exceeds the reference level and their length exceeds the following:

(B.2.1) $\frac{1}{4}$ in. (6.0 mm) for t up to $\frac{3}{4}$ in. (19.0 mm).

(B.2.2) $\frac{1}{3}t$ for t from $\frac{3}{4}$ in. (19.0 mm) to $2\frac{1}{4}$ in. (57.0 mm).

(B.2.3) $\frac{3}{4}$ in. (19.0 mm) for t over $2\frac{1}{4}$ in. (57.0 mm) where t is the thickness of the weld being examined. If the weld joins two members having different thicknesses at the weld, t is the thinner of these two thicknesses.

137 PRESSURE TESTS

137.1 General Requirements

137.1.1 Subassemblies. When conducted in accordance with the requirements of this Code, the pressure testing of piping systems to ensure leak tightness shall be acceptable for the determination of any leaks in piping subassemblies.

137.1.2 Temperature of Test Medium. The temperature of the test medium shall be that of the available source unless otherwise specified by the owner. The test pressure shall not be applied until the system and the pressurizing medium are approximately at the same temperature. When conducting pressure tests at low metal temperatures, the possibility of brittle fracture shall be considered.

137.1.3 Personnel Protection. Suitable precautions in the event of piping system rupture shall be taken to eliminate hazards to personnel in the proximity of lines being tested.

137.1.4 Maximum Stress During Test. At no time during the pressure test shall any part of the piping

system be subjected to a stress greater than that permitted by para. 102.3.3(B).

137.1.5 Testing Schedule. Pressure testing shall be performed following the completion of postweld heat treatment, required by para. 132, nondestructive examinations required by Table 136.4, and all other fabrication, assembly and erection activities required to provide the system or portions thereof subjected to the pressure test with pressure retaining capability.

137.2 Preparation for Testing

137.2.1 Exposure of Joints. All joints including welds not previously pressure tested shall be left uninsulated and exposed for examination during the test. By prior agreement the complete system or portions thereof subject to test may be insulated prior to the test period provided an extended holding time pressurization of the system is performed to check for possible leakage through the insulation barrier.

137.2.2 Addition of Temporary Supports. Piping systems designed for vapor or gas shall be provided with additional temporary supports if necessary to support the weight of the test liquid. Such supports shall meet the requirements for testing and system cleanup procedures described in para. 122.10.

137.2.3 Restraint or Isolation of Expansion Joints. Expansion joints shall be provided with temporary restraint if required for the additional pressure load under test, or they shall be isolated during the system test.

137.2.4 Isolation of Equipment and Piping Not Subjected to Pressure Test. Equipment that is not to be subjected to the pressure test shall be either disconnected from the system or isolated by a blank or similar means. Valves may be used for this purpose provided that valve closure is suitable for the proposed test pressure. Owner shall be aware of the limitations of pressure and temperature for each valve subject to test conditions and as further described in para. 107.1(C). Isolated equipment and piping must be vented.

137.2.5 Treatment of Flanged Joints Containing Blanks. Flanged joints at which blanks are inserted to blank off other equipment during the test need not be tested after removal of the blank provided the requirements of para. 137.7.1 are subsequently performed.

137.2.6 Precautions Against Test Medium Expansion. If a pressure test is to be maintained for a period of time during which the test medium in the system is subject to thermal expansion, precautions shall be taken to avoid excessive pressure. A pressure relief device set at $1\frac{1}{3}$ times the test pressure is recommended during the pressure test, provided the requirements of paras. 137.1.4, 137.4.5, and 137.5.5 are not exceeded.

137.3 Requirements for Specific Piping Systems

137.3.1 Boiler External Piping. Boiler external piping [see para. 100.1.2(A)] shall be hydrostatically tested in accordance with PG-99 of Section I of the ASME Boiler and Pressure Vessel Code. The test shall be conducted in the presence of the Authorized Inspector.

137.3.2 Nonboiler External Piping. All nonboiler external piping shall be hydrostatically tested in accordance with para. 137.4. As an alternative, when specified by the owner, the piping may be leak tested in accordance with para. 137.5, 137.6, or 137.7. Lines open to the atmosphere, such as vents or drains downstream of the last shutoff valve, need not be tested.

137.4 Hydrostatic Testing

137.4.1 Material. When permitted by the Material Specification, a system hydrostatic test may be performed in lieu of the hydrostatic test required by the material specifications for material used in the piping subassembly or system provided the minimum test pressure required for the piping system is met.

137.4.2 Provision of Air Vents at High Points. Vents shall be provided at all high points of the piping system in the position in which the test is to be conducted to purge air pockets while the component or system is filling. Venting during the filling of the system may be provided by the loosening of flanges having a minimum of four bolts or by the use of equipment vents.

137.4.3 Test Medium. Water shall normally be used as the test medium unless otherwise specified by the owner. Test water shall be clean and shall be of such quality as to minimize corrosion of the materials in the piping system. Further recommended precautions on the quality of test water used for hydrotesting of austenitic (300 series) and ferritic (400 series) stainless steels are contained in Nonmandatory Appendix IV, para. IV-3.4.

137.4.4 Check of Test Equipment Before Applying Pressure. The test equipment shall be examined before pressure is applied to ensure that it is tightly connected. All low-pressure filling lines and all other items not subject to the test pressure shall be disconnected or isolated by valves or other suitable means.

137.4.5 Required Hydrostatic Test Pressure. The hydrostatic test pressure at any point in the piping system shall not be less than 1.5 times the design pressure, but shall not exceed the maximum allowable test pressure of any nonisolated components, such as vessels, pumps, or valves, nor shall it exceed the limits imposed by para. 102.3.3(B). The pressure shall be continuously maintained for a minimum time of 10 min and may then be reduced to the design pressure and held for such time as may be necessary to conduct the examinations for leakage. Examinations for leakage shall be made of all joints and connections. The piping system, exclusive

of possible localized instances at pump or valve packing, shall show no visual evidence of weeping or leaking.

137.5 Pneumatic Testing

137.5.1 General. Except for preliminary testing in accordance with para. 137.5.4, pneumatic testing shall not be used unless the owner specifies pneumatic testing or permits its use as an alternative. It is recommended that pneumatic testing be used only when one of the following conditions exists:

(A) when piping systems are so designed that they cannot be filled with water

(B) when piping systems are to be used in services where traces of the testing medium cannot be tolerated

137.5.2 Test Medium. The gas used as the test medium shall be nonflammable and nontoxic. Since compressed gas may be hazardous when used as a testing medium, it is recommended that special precautions for protection of personnel be observed when a gas under pressure is used as the test medium.

137.5.3 Check of Test Equipment Before Applying Pressure. The test equipment shall be examined before pressure is applied to ensure that it is tightly connected. All items not subjected to the test pressure shall be disconnected or isolated by valves or other suitable means.

137.5.4 Preliminary Test. A preliminary pneumatic test not to exceed 25 psig [175 kPa (gage)] may be applied, prior to other methods of leak testing, as a means of locating major leaks. If used, the preliminary pneumatic test shall be performed in accordance with the requirements of paras. 137.5.2 and 137.5.3.

137.5.5 Required Pneumatic Test Pressure. The pneumatic test pressure shall be not less than 1.2 nor more than 1.5 times the design pressure of the piping system. The test pressure shall not exceed the maximum allowable test pressure of any nonisolated component, such as vessels, pumps, or valves, in the system. The pressure in the system shall gradually be increased to not more than one-half of the test pressure, after which the pressure shall be increased in steps of approximately one-tenth of the test pressure until the required test pressure has been reached. The pressure shall be continuously maintained for a minimum time of 10 min. It shall then be reduced to the lesser of design pressure or 100 psig [700 kPa (gage)] and held for such time as may be necessary to conduct the examination for leakage. Examination for leakage detected by soap bubble or equivalent method shall be made of all joints and connections. The piping system, exclusive of possible localized instances at pump or valve packing, shall show no evidence of leaking.

137.6 Mass-Spectrometer and Halide Testing

137.6.1 When specified by the owner, systems with conditions of operation and design that require testing methods having a greater degree of sensitivity than can be obtained by a hydrostatic or pneumatic test shall be tested by a method, such as helium mass-spectrometer test or halide test, which has the required sensitivity.

137.6.2 When a mass-spectrometer or halide test is performed, it shall be conducted in accordance with the instructions of the manufacturer of the test equipment. In all cases a calibrated reference leak, with a leak rate not greater than the maximum permissible leakage from the system, shall be used. The equipment shall be calibrated against the reference leak in such a way that the system leakage measured by the equipment can be determined to be not greater than the leak rate of the reference leak.

137.7 Initial Service Testing

137.7.1 When specified by the owner, an initial service test and examination is acceptable when other types of tests are not practical or when leak tightness is demonstrable due to the nature of the service. One example is piping where shut-off valves are not available for isolating a line and where temporary closures are impractical. Others may be systems where during the course of checking out of pumps, compressors, or other equipment, ample opportunity is afforded for examination for leakage prior to full scale operation. An initial service test is not applicable to boiler external piping.

137.7.2 When performing an initial service test, the piping system shall be gradually brought up to normal operating pressure and continuously held for a minimum time of 10 min. Examination for leakage shall be made of all joints and connections. The piping system exclusive of possible localized instances at pump or valve packing shall show no visual evidence of weeping or leaking.

137.8 Retesting After Repair or Additions

137.8.1 Repairs may be made to the pressure parts of boiler external piping after the hydrostatic test required by para. 137.3.1, provided the requirements of PW-54.2 of Section I of the ASME Boiler and Pressure Vessel Code are met.

137.8.2 Nonpressure parts may be welded to the pressure parts of boiler external piping after the hydrostatic test required by para. 137.3.1, provided the requirements of PW-54.3 of Section I of the ASME Boiler and Pressure Vessel Code are met.

137.8.3 If repairs or additions to nonboiler external piping are made following a test, the affected piping shall be retested in accordance with the provisions of

para. 137.3.2. However, a system need not be retested after seal welding or after attachments of lugs, brackets, insulation supports, nameplates, or other nonpressure retaining attachments provided

(A) the attachment fillet weld does not exceed $\frac{3}{8}$ in. (10.0 mm) thickness or, if a full penetration weld is used, the material attached does not exceed the nominal thickness of the pressure retaining member or $\frac{1}{2}$ in. (12.0 mm), whichever is less

(B) welds shall be preheated as required by para. 131

(C) welds shall be examined as required by Table 136.4

(D) seal welds shall be examined for leakage after system startup

137.8.4 All weld defect repairs shall be made in accordance with para. 127.4.11.

Chapter VII

Operation and Maintenance

(16) 138 GENERAL

Safety is the overriding concern in design, operation, and maintenance of power piping. Managing safe piping service begins with the initial project concept and continues throughout the service life of the piping system. The Operating Company is responsible for the safe operation and maintenance of its power piping.

The Code does not prescribe a detailed set of operating and maintenance procedures that will encompass all cases. Each Operating Company shall develop operation and maintenance procedures for piping systems deemed necessary to ensure safe facility operations based on the provisions of this Code, relevant industry experience, the Operating Company's experience and knowledge of its facility, and conditions under which the piping systems are operated. The additional requirements described in subsequent paragraphs apply to covered piping systems (CPS). At the owner's discretion, other piping systems may be included.

(16) 139 OPERATION AND MAINTENANCE PROCEDURES

For CPS, this shall be accomplished by the issuance of written operation and maintenance procedures. The operation and maintenance procedures established by the Operating Company for ensuring safe operation of its CPS may vary, but the following aspects shall be covered:

- (A) operation of piping system within design limits
- (B) documentation of system operating hours and modes of operation
- (C) documentation of actual operating temperatures and pressures
- (D) documentation of significant system transients or excursions including thermal hydraulic events (e.g., steam hammers, liquid slugging)
- (E) documentation of modifications, repairs, and replacements, including welding procedures used and NDE results
- (F) documentation of maintenance of pipe supports for piping operating within the creep regime
- (G) documentation of maintenance of piping system elements such as vents, drains, relief valves, desuperheaters, and instrumentation necessary for safe operation

(H) assessment of degradation mechanisms, including, but not limited to, creep, fatigue, graphitization, corrosion, erosion, and flow accelerated corrosion (FAC)

(I) quality of flow medium (e.g., dissolved oxygen, pH)

(J) documentation of the condition assessment (see para. 140)

(K) other required maintenance

140 CONDITION ASSESSMENT OF CPS

(16)

A program shall be established to provide for the assessment and documentation of the condition of all CPS. The documentation shall include a statement as to any actions necessary for continued safe operation. A condition assessment shall be performed at periodic intervals as determined by an engineering evaluation.

Condition assessments shall be made of CPS based on established industry practices. The condition assessment may range from a review of previous inspection findings and operating history since the previous inspection, to a thorough nondestructive examination (NDE) and engineering evaluation. The extent of the assessment performed shall be established by the Operating Company or its designee with consideration of the age of the CPS, the previous documented assessment, and anticipated operating conditions.

The CPS condition assessment program shall include implementation of weld examination and hanger inspection methods necessary for evaluating the impact of the applicable material degradation mechanism for the identified piping system.

The condition assessment documentation, in a form established by the Operating Company, should contain (but not be limited to) as many of the following elements as available:

- (A) system name.
- (B) listing of original material specifications and their editions.
- (C) design diameters and wall thicknesses.
- (D) design temperature and pressure.
- (E) normal operating temperature and pressure.
- (F) operating hours, both cumulative (from initial operation) and since last condition assessment.
- (G) actual modes of operation since last condition assessment (such as the number of hot, warm, and cold starts).

(H) pipe support hot and cold walk-down readings and conditions since last condition assessment for piping systems that are operated within the creep regime.

(I) modifications and repairs since last condition assessment.

(J) description and list of any dynamic events, including thermal hydraulic events, since the last condition assessment (see Nonmandatory Appendix V, para. V-11 for examples) that produced visual evidence of distortion or damage. Repetitive dynamic events (with or without visual evidence) should be included when identified by operators or plant personnel (see para. 146).

(K) actual pipe wall thickness and outside diameter measurements taken since the last condition assessment as appropriate based on service.

(L) summary of pipe system inspection findings, including list of areas of concern.

(M) recommendations for reinspection interval and scope.

Guidance on condition assessment may be found in Nonmandatory Appendix V of this Code.

(16) 141 CPS RECORDS

The records identified below, when available, shall be maintained and accessible for the life of the piping systems.

141.1 General

Covered piping system records shall consist of, but not be limited to,

- (A) any procedures required by para. 139
- (B) any condition assessment documentation required by para. 140
- (C) original, as-built, as modified, or updated piping drawings
- (D) original, as-built, as modified, or updated pipe support drawings
- (E) results from piping stress or flexibility analysis
- (F) piping system diagrams [flow, piping, and instrumentation (P&IDs), and/or process diagrams]
- (G) valve and other inline equipment data used in original piping design stress analysis
- (H) additional documentation requirements as identified in paras. 141.2, 141.3, 141.4, and 141.5

141.2 Materials

The owner shall establish a material history for each covered piping system to the extent necessary to permit evaluation and analysis of an existing condition. The records listed below are to be included in the material history and be traceable to specific components in a piping system. Additional records may be included as deemed necessary.

- (A) procurement documents, including specifications

- (B) original service date and original operating parameters

- (C) list of materials, both original and replacement, with system location and material specification

- (D) physical and mechanical properties from material test reports, including the following as applicable:

- (D.1) Manufacturer's Material Test Reports or Certificate of Conformance

- (D.2) chemical composition data

- (D.3) impact test data

- (D.4) information regarding special processing, i.e., welding, postweld heat treatment, mechanical working, bending including post-bending heat treatment, etc.

- (E) wall thicknesses from construction or maintenance records, including design minimum wall requirements

- (F) records of alterations or repairs

- (G) summary of design requirements

- (H) actual operating conditions recorded and maintained to facilitate creep and fatigue evaluations of components

- (I) special coatings, linings, or other designs for corrosion or erosion resistance

141.3 Installation, Modification, and Repair Records

Records for pressure-retaining welds in covered piping systems shall include, but not be limited to, the following:

- (A) original installation records
- (B) repair and modification records
- (C) welding procedures and qualification tests
- (D) nondestructive examination reports (including radiographs, digital or electronically stored NDE reports, etc.)
- (E) heat treatment performed, including time/temperature charts

141.4 Failure Analysis

The owner is responsible for investigating all failures in covered piping systems. A report of the results of this investigation is to be included in the material history file and, as a minimum, contain the following information:

- (A) record of any operating or test experience of the failed components or supports
- (B) any previous failure history of the component
- (C) any special conditions (corrosion, extraordinary loads, thermal excursions, etc.) that may have contributed to failure
- (D) conclusions of damage mechanism(s) and cause of failure

141.5 Restoration After Failure

The owner is responsible for documenting actions taken to restore failed components, including

- (A) recommendations for actions that are intended to minimize recurrence and documentation of satisfactory implementation

(B) recommendations, if any, for similar action that should be taken in other piping systems containing similar conditions or components

142 PIPING AND PIPE-SUPPORT MAINTENANCE PROGRAM AND PERSONNEL REQUIREMENTS

142.1 Maintenance Program

The maintenance program shall adhere to the requirements of paras. 138, 139, 140, 141, and 144. For further guidelines regarding the maintenance program, refer to Nonmandatory Appendix V, para. V-5.1.

142.2 Personnel

142.2.1 Only qualified personnel shall be responsible for executing the maintenance program of the Operating Company. For further guidelines regarding typical maintenance program responsibilities, see Nonmandatory Appendix V, para. V-5.2.

142.2.2 Review of records and failure reports, and decisions concerning corrective actions or repairs, shall be carried out by or under the direction of qualified personnel.

142.2.3 Welding and Heat Treatment Personnel

(A) Welders shall be qualified to approved welding procedures. Qualification of weld procedures and the qualification performance of the welder shall be in accordance with the requirements of para. 127.5.

(B) Qualified personnel shall perform preheat and postheat treatment operations as described in the requirements of paras. 131 and 132.

142.2.4 Examination, Inspection, and Testing Personnel. Qualified personnel shall perform nondestructive examinations (NDE), including visual inspections and leak tests (LT) in accordance with the requirements of para. 136.

144 CPS WALKDOWNS

The Operating Company shall develop and implement a program requiring documentation of piping support readings and recorded piping system displacements. Guidelines for this program are provided in Nonmandatory Appendix V, para. V-7. Piping system

drawings or sketches, including the identification of all supports, and piping support walkdown forms should be used as part of the hot and cold walkdowns. The condition assessment documentation (on paper or electronic media) shall comply with para. 140(H).

The Operating Company shall evaluate the effects of unexpected piping position changes, significant vibrations, and malfunctioning supports on the piping system's integrity and safety. Significant displacement variations from the expected design displacements shall be considered to assess the piping system's integrity. Subsequent evaluations and corrective actions may necessitate activities such as detailed examinations of critical weldments and support adjustments, repairs, and replacement of individual supports and restraints.

145 MATERIAL DEGRADATION MECHANISMS

Creep is stress-, time-, temperature-, and material-dependent plastic deformation under load. Stress allowables for materials having time-dependent properties are noted with italics in Mandatory Appendix A. Material stress rupture or creep properties govern the stress allowables within this temperature regime and may be important in the piping system evaluation.

The Operating Company shall develop and implement a program requiring data collection and evaluation of high-priority areas for CPS materials operating in the creep range. Guidelines provided in para. V-12 may be used for this program, which may also include non-CPS piping operating in the creep regime.

146 DYNAMIC LOADING

For those dynamic events identified in para. 140(J), document the following, as appropriate:

- (A) date, time, and preceding operating conditions (as available)
- (B) the nature and location of any damage
- (C) the results of any investigation
- (D) the results of any analysis or NDE performed
- (E) the acceptability of any effects or any corrective action taken, e.g., changes in operating procedure, changes in system design or piping supports and restraints, and any repairs or replacements

MANDATORY APPENDICES

MANDATORY APPENDIX A ALLOWABLE STRESS TABLES

Begins on next page.

Table A-1 Carbon Steel

Spec. No.	Grade	Type or Class	Nominal Composition	P-No.	Notes	Specified Minimum Tensile, ksi	Specified Minimum Yield, ksi	E or F
Seamless Pipe and Tube								
A53	A	S	C	1	(2)	48	30	1.00
	B	S	C-Mn	1	(2)	60	35	1.00
A106	A	...	C-Si	1	(2)	48	30	1.00
	B	...	C-Si	1	(2)	60	35	1.00
	C	...	C-Si	1	(2)	70	40	1.00
A179	C	1	(1)(2)(5)	(47)	26	1.00
A192	C-Si	1	(2)(5)	(47)	26	1.00
A210	A-1	...	C-Si	1	(2)	60	37	1.00
	C	...	C-Mn-Si	1	(2)	70	40	1.00
A333	1	...	C-Mn	1	(1)	55	30	1.00
	6	...	C-Mn-Si	1	...	60	35	1.00
A369	FPA	...	C-Si	1	(2)	48	30	1.00
	FPB	...	C-Mn	1	(2)	60	35	1.00
API 5L	A	...	C	1	(1)(2)(14)	48	30	1.00
	B	...	C-Mn	1	(1)(2)(14)	60	35	1.00
Furnace Butt Welded Pipe								
A53	...	F	C	1	(4)	48	30	0.60
API 5L	A25	I & II	C	1	(1)(4)(14)	45	25	0.60
Electric Resistance Welded Pipe and Tube								
A53	A	E	C	1	(2)	48	30	0.85
	B	E	C-Mn	1	(2)	60	35	0.85
A135	A	...	C	1	(1)(2)	48	30	0.85
	B	...	C-Mn	1	(1)(2)	60	35	0.85
A178	A	...	C	1	(2)(5)	(47)	26	0.85
	C	...	C	1	(2)	60	37	0.85
A214	C	1	(1)(2)(5)	(47)	26	0.85
A333	1	...	C-Mn	1	(1)	55	30	0.85
	6	...	C-Mn-Si	1	...	60	35	0.85

Table A-1 Carbon Steel

Maximum Allowable Stress Values in Tension, ksi, for Metal Temperature, °F, Not Exceeding											Spec. No.
100	200	300	400	500	600	650	700	750	800	Grade	
Seamless Pipe and Tube											
13.7	13.7	13.7	13.7	13.7	13.7	13.7	12.5	10.7	9.0	A	A53
17.1	17.1	17.1	17.1	17.1	17.1	17.1	15.6	13.0	10.8	B	
13.7	13.7	13.7	13.7	13.7	13.7	13.7	12.5	10.7	9.3	A	A106
17.1	17.1	17.1	17.1	17.1	17.1	17.1	15.6	13.0	10.8	B	
20.0	20.0	20.0	20.0	20.0	20.0	19.8	18.3	14.8	12.0	C	
13.4	13.4	13.4	13.4	13.4	13.3	12.8	12.4	10.7	9.2	...	A179
13.4	13.4	13.4	13.4	13.4	13.3	12.8	12.4	10.7	9.0	...	A192
17.1	17.1	17.1	17.1	17.1	17.1	17.1	15.6	13.0	10.8	A-1	A210
20.0	20.0	20.0	20.0	20.0	20.0	19.8	18.3	14.8	12.0	C	
15.7	15.7	15.7	15.7	15.7	15.3	14.8	1	A333
17.1	17.1	17.1	17.1	17.1	17.1	17.1	15.6	6	
13.7	13.7	13.7	13.7	13.7	13.7	13.7	12.5	10.7	9.0	FPA	A369
17.1	17.1	17.1	17.1	17.1	17.1	17.1	15.6	13.0	10.8	FPB	
13.7	13.7	13.7	13.7	13.7	13.7	13.7	12.5	10.7	9.0	A	API 5L
17.1	17.1	17.1	17.1	17.1	17.1	17.1	15.6	13.0	10.8	B	
Furnace Butt Welded Pipe											
8.2	8.2	8.2	8.2	8.2	8.2	8.2	7.5	A53
7.7	7.7	7.7	7.7	A25	API 5L
Electric Resistance Welded Pipe and Tube											
11.7	11.7	11.7	11.7	11.7	11.7	11.7	10.6	9.1	7.7	A	A53
14.6	14.6	14.6	14.6	14.6	14.6	14.6	13.3	11.1	9.2	B	
11.7	11.7	11.7	11.7	11.7	11.7	11.7	10.6	9.1	7.9	A	A135
14.6	14.6	14.6	14.6	14.6	14.6	14.6	13.3	11.1	9.2	B	
11.4	11.4	11.4	11.4	11.4	11.3	10.9	10.5	9.1	7.7	A	A178
14.6	14.6	14.6	14.6	14.6	14.6	14.6	13.3	11.1	9.2	C	
11.4	11.4	11.4	11.4	11.4	11.3	10.9	10.5	9.1	7.8	...	A214
13.4	13.4	13.4	13.4	13.4	13.0	12.6	1	A333
14.6	14.6	14.6	14.6	14.6	14.6	14.6	13.3	6	

Table A-1 Carbon Steel (Cont'd)

Spec. No.	Grade	Type or Class	Nominal Composition	P-No.	Notes	Specified Minimum Tensile, ksi	Specified Minimum Yield, ksi	<i>E</i> or <i>F</i>
Electric Resistance Welded Pipe and Tube (Cont'd)								
API 5L	A25	I & II	C	1	(1)(14)	45	25	0.85
	A	...	C	1	(1)(2)(14)	48	30	0.85
	B	...	C-Mn	1	(1)(2)(14)	60	35	0.85
A587	C	1	(1)(2)	48	30	0.85
Electric Fusion Welded Pipe — Filler Metal Added								
A134	A283A	...	C	1	(1)(7)	45	24	0.80
	A283B	...	C	1	(1)(7)	50	27	0.80
	A283C	...	C	1	(1)(7)	55	30	0.80
	A283D	...	C	1	(1)(7)	60	33	0.80
A134	A285A	...	C	1	(1)(2)(8)	45	24	0.80
	A285B	...	C	1	(1)(2)(8)	50	27	0.80
	A285C	...	C	1	(1)(2)(8)	55	30	0.80
A139	A	...	C	1	(1)(2)(14)	48	30	0.80
	B	...	C-Mn	1	(1)(2)(14)	60	35	0.80
API 5L	A	...	C	1	(1)(2)(14)	48	30	0.90
	B	...	C-Mn	1	(1)(2)(14)	60	35	0.90
A671	CA55	10,13	C	1	(1)(2)(15)	55	30	0.90
	CA55	11,12	C	1	(1)(2)(15)	55	30	1.00
	CA55	20,23,30,33	C	1	(1)(2)	55	30	0.90
	CA55	21,22,31,32	C	1	(1)(2)	55	30	1.00
A671	CB60	10,13	C-Si	1	(1)(2)(15)	60	32	0.90
	CB60	11,12	C-Si	1	(1)(2)(15)	60	32	1.00
	CB60	20,23,30,33	C-Si	1	(1)(2)	60	32	0.90
	CB60	21,22,31,32	C-Si	1	(1)(2)	60	32	1.00
A671	CB65	10,13	C-Si	1	(1)(2)(15)	65	35	0.90
	CB65	11,12	C-Si	1	(1)(2)(15)	65	35	1.00
	CB65	20,23,30,33	C-Si	1	(1)(2)	65	35	0.90
	CB65	21,22,31,32	C-Si	1	(1)(2)	65	35	1.00
A671	CB70	10,13	C-Si	1	(1)(2)(15)	70	38	0.90
	CB70	11,12	C-Si	1	(1)(2)(15)	70	38	1.00
	CB70	20,23,30,33	C-Si	1	(1)(2)	70	38	0.90
	CB70	21,22,31,32	C-Si	1	(1)(2)	70	38	1.00
A671	CC60	10,13	C-Mn-Si	1	(1)(2)(15)	60	32	0.90
	CC60	11,12	C-Mn-Si	1	(1)(2)(15)	60	32	1.00
	CC60	20,23,30,33	C-Mn-Si	1	(1)(2)	60	32	0.90
	CC60	21,22,31,32	C-Mn-Si	1	(1)(2)	60	32	1.00

Table A-1 Carbon Steel (Cont'd)

Maximum Allowable Stress Values in Tension, ksi, for Metal Temperature, °F, Not Exceeding											Spec. No.
100	200	300	400	500	600	650	700	750	800	Grade	
Electric Resistance Welded Pipe and Tube (Cont'd)											
10.9	10.9	10.9	10.9	A25	API 5L
11.7	11.7	11.7	11.7	11.7	11.7	11.7	10.6	9.1	7.7	A	
14.6	14.6	14.6	14.6	14.6	14.6	14.6	13.3	11.1	9.2	B	
11.7	11.7	11.7	11.7	11.7	11.7	11.7	10.6	9.1	7.8	...	A587
Electric Fusion Welded Pipe — Filler Metal Added											
10.3	10.3	10.3	10.3	10.3	9.8	9.5	A283A	A134
11.4	11.4	11.4	11.4	11.4	11.0	10.7	A283B	
12.6	12.6	12.6	12.6	12.6	12.3	11.9	A283C	
13.7	13.7	13.7	13.7	13.7	13.5	13.0	A283D	
10.3	10.3	10.3	10.3	10.3	9.8	9.5	9.2	8.6	6.6	A285A	A134
11.4	11.4	11.4	11.4	11.4	11.0	10.7	10.0	8.8	6.5	A285B	
12.6	12.6	12.6	12.6	12.6	12.3	11.9	11.5	10.4	8.6	A285C	
11.0	11.0	11.0	11.0	11.0	11.0	11.0	10.0	8.6	7.4	A	A139
13.7	13.7	13.7	13.7	13.7	13.7	13.7	12.5	10.4	8.6	B	
12.3	12.3	12.3	12.3	12.3	12.3	12.3	11.3	9.6	8.3	A	API 5L
15.4	15.4	15.4	15.4	15.4	15.4	15.4	14.0	11.7	9.7	B	
14.1	14.1	14.1	14.1	14.1	13.8	13.3	12.9	11.7	9.7	CA55	A671
15.7	15.7	15.7	15.7	15.7	15.3	14.8	14.3	13.0	10.8	CA55	
14.1	14.1	14.1	14.1	14.1	13.8	13.3	12.9	11.7	9.7	CA55	
15.7	15.7	15.7	15.7	15.7	15.3	14.8	14.3	13.0	10.8	CA55	
15.4	15.4	15.4	15.4	15.4	14.7	14.2	13.7	11.7	9.7	CB60	A671
17.1	17.1	17.1	17.1	17.1	16.4	15.8	15.3	13.0	10.8	CB60	
15.4	15.4	15.4	15.4	15.4	14.7	14.2	13.7	11.7	9.7	CB60	
17.1	17.1	17.1	17.1	17.1	16.4	15.8	15.3	13.0	10.8	CB60	
16.7	16.7	16.7	16.7	16.7	16.1	15.6	15.0	12.5	10.3	CB65	A671
18.6	18.6	18.6	18.6	18.6	17.9	17.3	16.7	13.9	11.4	CB65	
16.7	16.7	16.7	16.7	16.7	16.1	15.6	15.0	12.5	10.3	CB65	
18.6	18.6	18.6	18.6	18.6	17.9	17.3	16.7	13.9	11.4	CB65	
18.0	18.0	18.0	18.0	18.0	17.5	16.9	16.3	13.3	10.8	CB70	A671
20.0	20.0	20.0	20.0	20.0	19.4	18.8	18.1	14.8	12.0	CB70	
18.0	18.0	18.0	18.0	18.0	17.5	16.9	16.3	13.3	10.8	CB70	
20.0	20.0	20.0	20.0	20.0	19.4	18.8	18.1	14.8	12.0	CB70	
15.4	15.4	15.4	15.4	15.4	14.7	14.2	13.7	11.7	9.7	CC60	A671
17.1	17.1	17.1	17.1	17.1	16.4	15.8	15.3	13.0	10.8	CC60	
15.4	15.4	15.4	15.4	15.4	14.7	14.2	13.7	11.7	9.7	CC60	
17.1	17.1	17.1	17.1	17.1	16.4	15.8	15.3	13.0	10.8	CC60	

Table A-1 Carbon Steel (Cont'd)

Spec. No.	Grade	Type or Class	Nominal Composition	P-No.	Notes	Specified Minimum Tensile, ksi	Specified Minimum Yield, ksi	E or F
Electric Fusion Welded Pipe — Filler Metal Added (Cont'd)								
A671	CC65	10,13	C-Mn-Si	1	(1)(2)(15)	65	35	0.90
	CC65	11,12	C-Mn-Si	1	(1)(2)(15)	65	35	1.00
	CC65	20,23,30,33	C-Mn-Si	1	(1)(2)	65	35	0.90
	CC65	21,22,31,32	C-Mn-Si	1	(1)(2)	65	35	1.00
A671	CC70	10,13	C-Mn-Si	1	(1)(2)(15)	70	38	0.90
	CC70	11,12	C-Mn-Si	1	(1)(2)(15)	70	38	1.00
	CC70	20,23,30,33	C-Mn-Si	1	(1)(2)	70	38	0.90
	CC70	21,22,31,32	C-Mn-Si	1	(1)(2)	70	38	1.00
A671	CK75	10,13	C-Mn-Si	1	(1)(2)(15)	75	42	0.90
	CK75	11,12	C-Mn-Si	1	(1)(2)(15)	75	42	1.00
	CK75	20,23,30,33	C-Mn-Si	1	(1)(2)	75	40	0.90
	CK75	21,22,31,32	C-Mn-Si	1	(1)(2)	75	40	1.00
A671	CD70	10,13	C-Mn-Si	1	(1)(2)(15)	70	50	0.90
	CD70	11,12	C-Mn-Si	1	(1)(2)(15)	70	50	1.00
	CD70	20,23,30,33	C-Mn-Si	1	(1)(3)	70	50	0.90
	CD70	21,22,31,32	C-Mn-Si	1	(1)(3)	70	50	1.00
A671	CD80	10,13	C-Mn-Si	1	(1)(15)	80	60	0.90
	CD80	11,12	C-Mn-Si	1	(1)(15)	80	60	1.00
	CD80	20,23	C-Mn-Si	1	(1)(3)	80	60	0.90
	CD80	21,22	C-Mn-Si	1	(1)(3)	80	60	1.00
A672	A45	10,13	C	1	(1)(2)(15)	45	24	0.90
	A45	11,12	C	1	(1)(2)(15)	45	24	1.00
	A45	20,23,30,33	C	1	(1)(2)	45	24	0.90
	A45	21,22,31,32	C	1	(1)(2)	45	24	1.00
A672	A50	10,13	C	1	(1)(2)(15)	50	27	0.90
	A50	11,12	C	1	(1)(2)(15)	50	27	1.00
	A50	20,23,30,33	C	1	(1)(2)	50	27	0.90
	A50	21,22,31,32	C	1	(1)(2)	50	27	1.00
A672	A55	10,13	C	1	(1)(2)(15)	55	30	0.90
	A55	11,12	C	1	(1)(2)(15)	55	30	1.00
	A55	20,23,30,33	C	1	(1)(2)	55	30	0.90
	A55	21,22,31,32	C	1	(1)(2)	55	30	1.00
A672	B55	10,13	C	1	(1)(2)(15)	55	30	0.90
	B55	11,12	C	1	(1)(2)(15)	55	30	1.00
	B55	20,23,30,33	C	1	(1)(2)	55	30	0.90
	B55	21,22,31,32	C	1	(1)(2)	55	30	1.00
A672	B60	10,13	C	1	(1)(2)(15)	60	32	0.90
	B60	11,12	C	1	(1)(2)(15)	60	32	1.00
	B60	20,23,30,33	C	1	(1)(2)	60	32	0.90
	B60	21,22,31,32	C	1	(1)(2)	60	32	1.00

Table A-1 Carbon Steel (Cont'd)

Maximum Allowable Stress Values in Tension, ksi, for Metal Temperature, °F, Not Exceeding											Spec. No.
100	200	300	400	500	600	650	700	750	800	Grade	
Electric Fusion Welded Pipe — Filler Metal Added (Cont'd)											
16.7	16.7	16.7	16.7	16.7	16.1	15.6	15.0	12.5	10.3	CC65	A671
18.6	18.6	18.6	18.6	18.6	17.9	17.3	16.7	13.9	11.4	CC65	
16.7	16.7	16.7	16.7	16.7	16.1	15.6	15.0	12.5	10.3	CC65	
18.6	18.6	18.6	18.6	18.6	17.9	17.3	16.7	13.9	11.4	CC65	
18.0	18.0	18.0	18.0	18.0	17.5	16.9	16.3	13.3	10.8	CC70	A671
20.0	20.0	20.0	20.0	20.0	19.4	18.8	18.1	14.8	12.0	CC70	
18.0	18.0	18.0	18.0	18.0	17.5	16.9	16.3	13.3	10.8	CC70	
20.0	20.0	20.0	20.0	20.0	19.4	18.8	18.1	14.8	12.0	CC70	
19.3	19.3	19.3	19.3	19.3	19.3	18.7	17.6	14.1	11.3	CK75	A671
21.4	21.4	21.4	21.4	21.4	21.4	20.8	19.6	15.7	12.6	CK75	
19.3	19.3	19.3	19.3	19.3	18.4	17.8	17.2	14.1	11.3	CK75	
21.4	21.4	21.4	21.4	21.4	20.4	19.8	19.1	15.7	12.6	CK75	
18.0	18.0	17.7	17.6	17.6	17.6	17.6	CD70	A671
20.0	20.0	19.7	19.5	19.5	19.5	19.5	CD70	
18.0	18.0	17.7	17.6	17.6	17.6	17.6	CD70	
20.0	20.0	19.7	19.5	19.5	19.5	19.5	CD70	
20.6	20.6	20.3	20.1	20.1	20.1	20.1	CD80	A671
22.9	22.9	22.6	22.3	22.3	22.3	22.3	CD80	
20.6	20.6	20.3	20.1	20.1	20.1	20.1	CD80	
22.9	22.9	22.6	22.3	22.3	22.3	22.3	CD80	
11.6	11.6	11.6	11.6	11.6	11.0	10.7	10.3	9.6	8.1	A45	A672
12.9	12.9	12.9	12.9	12.9	12.3	11.9	11.5	10.7	9.0	A45	
11.6	11.6	11.6	11.6	11.6	11.0	10.7	10.3	9.6	8.1	A45	
12.9	12.9	12.9	12.9	12.9	12.3	11.9	11.5	10.7	9.0	A45	
12.9	12.9	12.9	12.9	12.9	12.4	12.0	11.3	10.1	8.6	A50	A672
14.3	14.3	14.3	14.3	14.3	13.8	13.3	12.5	11.2	9.6	A50	
12.9	12.9	12.9	12.9	12.9	12.4	12.0	11.3	10.1	8.6	A50	
14.3	14.3	14.3	14.3	14.3	13.8	13.3	12.5	11.2	9.6	A50	
14.1	14.1	14.1	14.1	14.1	13.8	13.3	12.9	10.9	9.2	A55	A672
15.7	15.7	15.7	15.7	15.7	15.3	14.8	14.3	12.1	10.2	A55	
14.1	14.1	14.1	14.1	14.1	13.8	13.3	12.9	10.9	9.2	A55	
15.7	15.7	15.7	15.7	15.7	15.3	14.8	14.3	12.1	10.2	A55	
14.1	14.1	14.1	14.1	14.1	13.8	13.3	12.9	10.9	9.2	B55	A672
15.7	15.7	15.7	15.7	15.7	15.3	14.8	14.3	12.1	10.2	B55	
14.1	14.1	14.1	14.1	14.1	13.8	13.3	12.9	10.9	9.2	B55	
15.7	15.7	15.7	15.7	15.7	15.3	14.8	14.3	12.1	10.2	B55	
15.4	15.4	15.4	15.4	15.4	14.7	14.2	13.7	11.7	9.7	B60	A672
17.1	17.1	17.1	17.1	17.1	16.4	15.8	15.3	13.0	10.8	B60	
15.4	15.4	15.4	15.4	15.4	14.7	14.2	13.7	11.7	9.7	B60	
17.1	17.1	17.1	17.1	17.1	16.4	15.8	15.3	13.0	10.8	B60	

Table A-1 Carbon Steel (Cont'd)

Spec. No.	Grade	Type or Class	Nominal Composition	P-No.	Notes	Specified Minimum Tensile, ksi	Specified Minimum Yield, ksi	E or F
Electric Fusion Welded Pipe — Filler Metal Added (Cont'd)								
A672	B65	10,13	C	1	(1)(2)(15)	65	35	0.90
	B65	11,12	C	1	(1)(2)(15)	65	35	1.00
	B65	20,23,30,33	C	1	(1)(2)	65	35	0.90
	B65	21,22,31,32	C	1	(1)(2)	65	35	1.00
A672	B70	10,13	C	1	(1)(2)(15)	70	38	0.90
	B70	11,12	C	1	(1)(2)(15)	70	38	1.00
	B70	20,23,30,33	C	1	(1)(2)	70	38	0.90
	B70	21,22,31,32	C	1	(1)(2)	70	38	1.00
A672	C55	10,13	C	1	(1)(2)(15)	55	30	0.90
	C55	11,12	C	1	(1)(2)(15)	55	30	1.00
	C55	20,23,30,33	C	1	(1)(2)	55	30	0.90
	C55	21,22,31,32	C	1	(1)(2)	55	30	1.00
A672	C60	10,13	C	1	(1)(2)(15)	60	32	0.90
	C60	11,12	C	1	(1)(2)(15)	60	32	1.00
	C60	20,23,30,33	C	1	(1)(2)	60	32	0.90
	C60	21,22,31,32	C	1	(1)(2)	60	32	1.00
A672	C65	10,13	C	1	(1)(2)(15)	65	35	0.90
	C65	11,12	C	1	(1)(2)(15)	65	35	1.00
	C65	20,23,30,33	C	1	(1)(2)	65	35	0.90
	C65	21,22,31,32	C	1	(1)(2)	65	35	1.00
A672	C70	10,13	C	1	(1)(2)(15)	70	38	0.90
	C70	11,12	C	1	(1)(2)(15)	70	38	1.00
	C70	20,23,30,33	C	1	(1)(2)	70	38	0.90
	C70	21,22,31,32	C	1	(1)(2)	70	38	1.00
A672	D70	10,13	C-Mn-Si	1	(1)(15)	70	50	0.90
	D70	11,12	C-Mn-Si	1	(1)(15)	70	50	1.00
	D70	20,23,30,33	C-Mn-Si	1	(1)(3)	70	50	0.90
	D70	21,22,31,32	C-Mn-Si	1	(1)(3)	70	50	1.00
A672	D80	10,13	C-Mn-Si	1	(1)(15)	80	60	0.90
	D80	11,12	C-Mn-Si	1	(1)(15)	80	60	1.00
	D80	20,23	C-Mn-Si	1	(1)(3)	80	60	0.90
	D80	21,22	C-Mn-Si	1	(1)(3)	80	60	1.00
A672	N75	10,13	C-Mn-Si	1	(1)(2)(15)	75	42	0.90
	N75	11,12	C-Mn-Si	1	(1)(2)(15)	75	42	1.00
	N75	20,23,30,33	C-Mn-Si	1	(1)(2)	75	40	0.90
	N75	21,22,31,32	C-Mn-Si	1	(1)(2)	75	40	1.00
A691	CMSH-70	10,13	C-Mn-Si	1	(1)(15)	70	50	0.90
	CMSH-70	11,12	C-Mn-Si	1	(1)(15)	70	50	1.00
	CMSH-70	20,23,30,33	C-Mn-Si	1	(1)(3)	70	50	0.90
	CMSH-70	21,22,31,32	C-Mn-Si	1	(1)(3)	70	50	1.00

Table A-1 Carbon Steel (Cont'd)

Maximum Allowable Stress Values in Tension, ksi, for Metal Temperature, °F, Not Exceeding											Spec. No.
100	200	300	400	500	600	650	700	750	800	Grade	
Electric Fusion Welded Pipe — Filler Metal Added (Cont'd)											
16.7	16.7	16.7	16.7	16.7	16.1	15.6	15.0	12.5	10.3	B65	A672
18.6	18.6	18.6	18.6	18.6	17.9	17.3	16.7	13.9	11.4	B65	
16.7	16.7	16.7	16.7	16.7	16.1	15.6	15.0	12.5	10.3	B65	
18.6	18.6	18.6	18.6	18.6	17.9	17.3	16.7	13.9	11.4	B65	
18.0	18.0	18.0	18.0	18.0	17.5	16.9	16.3	13.3	10.8	B70	A672
20.0	20.0	20.0	20.0	20.0	19.4	18.8	18.1	14.8	12.0	B70	
18.0	18.0	18.0	18.0	18.0	17.5	16.9	16.3	13.3	10.8	B70	
20.0	20.0	20.0	20.0	20.0	19.4	18.8	18.1	14.8	12.0	B70	
14.1	14.1	14.1	14.1	14.1	13.8	13.3	12.9	10.9	9.2	C55	A672
15.7	15.7	15.7	15.7	15.7	15.3	14.8	14.3	12.1	10.2	C55	
14.1	14.1	14.1	14.1	14.1	13.8	13.3	12.9	10.9	9.2	C55	
15.7	15.7	15.7	15.7	15.7	15.3	14.8	14.3	12.1	10.2	C55	
15.4	15.4	15.4	15.4	15.4	14.7	14.2	13.7	11.7	9.7	C60	A672
17.1	17.1	17.1	17.1	17.1	16.4	15.8	15.3	13.0	10.8	C60	
15.4	15.4	15.4	15.4	15.4	14.7	14.2	13.7	11.7	9.7	C60	
17.1	17.1	17.1	17.1	17.1	16.4	15.8	15.3	13.0	10.8	C60	
16.7	16.7	16.7	16.7	16.7	16.1	15.6	15.0	12.5	10.3	C65	A672
18.6	18.6	18.6	18.6	18.6	17.9	17.3	16.7	13.9	11.4	C65	
16.7	16.7	16.7	16.7	16.7	16.1	15.6	15.0	12.5	10.3	C65	
18.6	18.6	18.6	18.6	18.6	17.9	17.3	16.7	13.9	11.4	C65	
18.0	18.0	18.0	18.0	18.0	17.5	16.9	16.3	13.3	10.8	C70	A672
20.0	20.0	20.0	20.0	20.0	19.4	18.8	18.1	14.8	12.0	C70	
18.0	18.0	18.0	18.0	18.0	17.5	16.9	16.3	13.3	10.8	C70	
20.0	20.0	20.0	20.0	20.0	19.4	18.8	18.1	14.8	12.0	C70	
18.0	18.0	17.7	17.6	17.6	17.6	17.6	D70	A672
20.0	20.0	19.7	19.5	19.5	19.5	19.5	D70	
18.0	18.0	17.7	17.6	17.6	17.6	17.6	D70	
20.0	20.0	19.7	19.5	19.5	19.5	19.5	D70	
20.6	20.6	20.3	20.1	20.1	20.1	20.1	D80	A672
22.9	22.9	22.6	22.3	22.3	22.3	22.3	D80	
20.6	20.6	20.3	20.1	20.1	20.1	20.1	D80	
22.9	22.9	22.6	22.3	22.3	22.3	22.3	D80	
19.3	19.3	19.3	19.3	19.3	18.4	17.8	17.2	14.1	11.3	N75	A672
21.4	21.4	21.4	21.4	21.4	20.4	19.8	19.1	15.7	12.6	N75	
19.3	19.3	19.3	19.3	19.3	18.4	17.8	17.2	14.1	11.3	N75	
21.4	21.4	21.4	21.4	21.4	20.4	19.8	19.1	15.7	12.6	N75	
18.0	18.0	17.7	17.6	17.6	17.6	17.6	CMSH-70	A691
20.0	20.0	19.7	19.5	19.5	19.5	19.5	CMSH-70	
18.0	18.0	17.7	17.6	17.6	17.6	17.6	CMSH-70	
20.0	20.0	19.7	19.5	19.5	19.5	19.5	CMSH-70	

Table A-1 Carbon Steel (Cont'd)

Spec. No.	Grade	Type or Class	Nominal Composition	P-No.	Notes	Specified Minimum Tensile, ksi	Specified Minimum Yield, ksi	E or F
Electric Fusion Welded Pipe — Filler Metal Added (Cont'd)								
A691	CMSH-80	10,13	C-Mn-Si	1	(1)(15)	80	60	0.90
	CMSH-80	11,12	C-Mn-Si	1	(1)(15)	80	60	1.00
	CMSH-80	20,23	C-Mn-Si	1	(1)(3)	80	60	0.90
	CMSH-80	21,22	C-Mn-Si	1	(1)(3)	80	60	1.00
A691	CMS-75	10,13	C-Mn-Si	1	(1)(2)(15)	75	42	0.90
	CMS-75	11,12	C-Mn-Si	1	(1)(2)(15)	75	42	1.00
	CMS-75	20,23,30,33	C-Mn-Si	1	(1)(2)	75	40	0.90
	CMS-75	21,22,31,32	C-Mn-Si	1	(1)(2)	75	40	1.00
Copper Brazed Tubing								
A254	C	...	(1)(9)(10)	42	25	1.00
Plate								
A36	C-Mn-Si	1	(1)(7)(11)	58	36	0.92
A283	A	...	C	1	(1)(7)	45	24	0.92
	B	...	C	1	(1)(7)	50	27	0.92
	C	...	C	1	(1)(7)	55	30	0.92
	D	...	C	1	(1)(7)	60	33	0.92
A285	A	...	C	1	(2)	45	24	1.00
	B	...	C	1	(2)	50	27	1.00
	C	...	C	1	(2)	55	30	1.00
A299	C-Mn-Si	1	(2)(13)	75	40	1.00
	C-Mn-Si	1	(2)(12)	75	42	1.00
A515	60	...	C-Si	1	(2)	60	32	1.00
	65	...	C-Si	1	(2)	65	35	1.00
	70	...	C-Si	1	(2)	70	38	1.00
A516	55	...	C-Si	1	(2)	55	30	1.00
	60	...	C-Mn-Si	1	(2)	60	32	1.00
	65	...	C-Mn-Si	1	(2)	65	35	1.00
	70	...	C-Mn-Si	1	(2)	70	38	1.00
Forgings								
A105	C-Si	1	(2)	70	36	1.00
A181	...	60	C-Si	1	(2)	60	30	1.00
	...	70	C-Si	1	(2)	70	36	1.00
A350	LF2	1	C-Mn-Si	1	(2)	70	36	1.00
	LF2	2	C-Mn-Si	1	(2)	70	36	1.00

Table A-1 Carbon Steel (Cont'd)

Maximum Allowable Stress Values in Tension, ksi, for Metal Temperature, °F, Not Exceeding											Spec. No.
100	200	300	400	500	600	650	700	750	800	Grade	
Electric Fusion Welded Pipe — Filler Metal Added (Cont'd)											
20.6	20.6	20.3	20.1	20.1	20.1	20.1	CMSH-80	A691
22.9	22.9	22.6	22.3	22.3	22.3	22.3	CMSH-80	
20.6	20.6	20.3	20.1	20.1	20.1	20.1	CMSH-80	
22.9	22.9	22.6	22.3	22.3	22.3	22.3	CMSH-80	
19.3	19.3	19.3	19.3	19.3	18.4	17.8	17.2	14.1	11.3	CMS-75	A691
21.4	21.4	21.4	21.4	21.4	20.4	19.8	19.1	15.7	12.6	CMS-75	
19.3	19.3	19.3	19.3	19.3	18.4	17.8	17.2	14.1	11.3	CMS-75	
21.4	21.4	21.4	21.4	21.4	20.4	19.8	19.1	15.7	12.6	CMS-75	
Copper Brazed Tubing											
6.0	5.5	4.8	3.0	A254
Plate											
15.2	15.2	15.2	15.2	15.2	15.2	15.2	A36
11.8	11.8	11.8	11.8	11.8	11.3	10.9	A	A283
13.1	13.1	13.1	13.1	13.1	12.7	12.3	B	
14.5	14.5	14.5	14.5	14.5	14.1	13.6	C	
15.8	15.8	15.8	15.8	15.8	15.5	15.0	D	
12.9	12.9	12.9	12.9	12.9	12.3	11.9	11.5	10.7	8.3	A	A285
14.3	14.3	14.3	14.3	14.3	13.8	13.3	12.5	11.0	9.4	B	
15.7	15.7	15.7	15.7	15.7	15.3	14.8	14.3	13.0	10.8	C	
21.4	21.4	21.4	21.4	21.4	20.4	19.8	19.1	15.7	12.6	...	A299
21.4	21.4	21.4	21.4	21.4	21.4	20.8	19.6	15.7	12.6	...	
17.1	17.1	17.1	17.1	17.1	16.4	15.8	15.3	13.0	10.8	60	A515
18.6	18.6	18.6	18.6	18.6	17.9	17.3	16.7	13.9	11.4	65	
20.0	20.0	20.0	20.0	20.0	19.4	18.8	18.1	14.8	12.6	70	
15.7	15.7	15.7	15.7	15.7	15.3	14.8	14.3	13.0	10.8	55	A516
17.1	17.1	17.1	17.1	17.1	16.4	15.8	15.3	13.0	10.8	60	
18.6	18.6	18.6	18.6	18.6	17.9	17.3	16.7	13.9	11.4	65	
20.0	20.0	20.0	20.0	20.0	19.4	18.8	18.1	14.8	12.0	70	
Forgings											
20.0	20.0	20.0	20.0	19.6	18.4	17.8	17.2	14.8	12.0	...	A105
17.1	17.1	17.1	17.1	16.3	15.3	14.8	14.3	13.0	10.8	...	A181
20.0	20.0	20.0	20.0	19.6	18.4	17.8	17.2	14.8	12.0	...	
20.0	20.0	20.0	20.0	19.6	18.4	17.8	17.2	14.8	12.0	LF2	A350
20.0	20.0	20.0	20.0	19.6	18.4	17.8	17.2	14.8	12.0	LF2	

Table A-1 Carbon Steel (Cont'd)

Spec. No.	Grade	Type or Class	Nominal Composition	P-No.	Notes	Specified Minimum Tensile, ksi	Specified Minimum Yield, ksi	<i>E</i> or <i>F</i>
Wrought Fittings (Seamless and Welded)								
A234	WPB	...	C-Si	1	(2)	60	35	1.00
	WPC	...	C-Si	1	(2)	70	40	1.00
Castings								
A216	WCA	...	C-Si	1	(2)(6)	60	30	0.80
	WCB	...	C-Si	1	(2)(6)	70	36	0.80
	WCC	...	C-Mn-Si	1	(2)(6)	70	40	0.80
Bars and Shapes								
A36	C-Mn-Si	1	(1)(2)	58	36	1.00
A992	C-Mn-Si	1	(1)(2)	65	50	1.00

GENERAL NOTES:

- The tabulated specifications are ANSI/ASTM or ASTM, except API 5L. For ASME Boiler and Pressure Vessel Code applications, see related specifications in Section II of the ASME Code.
- The stress values in this Table may be interpolated to determine values for intermediate temperatures.
- The P-Numbers indicated in this Table are identical to those adopted by ASME Boiler and Pressure Vessel Code. Qualification of welding procedures, welders, and welding operators is required and shall comply with the ASME Boiler and Pressure Vessel Code (Section IX) except as modified by para. 127.5.
- Tensile strengths and allowable stresses shown in "ksi" are "thousands of pounds per square inch."
- The materials listed in this Table shall not be used at design temperatures above those for which allowable stress values are given except as permitted by para. 122.6.2(G).
- The tabulated stress values are $S \times E$ (weld joint efficiency factor) or $S \times F$ (material quality factor), as applicable. Weld joint efficiency factors are shown in Table 102.4.3.
- Pressure-temperature ratings of piping components, as published in standards referenced in this Code, may be used for components meeting the requirements of those standards. The allowable stress values given in this Table are for use in designing piping components which are not manufactured in accordance with referenced standards.
- All the materials listed are classified as ferritic [see Table 104.1.2(A)].
- The tabulated stress values that are shown in italics are at temperatures in the range where creep and stress rupture strength govern the selection of stresses.
- See para. 124.1.2 for lower temperature limits.

Table A-1 Carbon Steel (Cont'd)

Maximum Allowable Stress Values in Tension, ksi, for Metal Temperature, °F, Not Exceeding											Spec. No.
100	200	300	400	500	600	650	700	750	800	Grade	
Wrought Fittings (Seamless and Welded)											
17.1	17.1	17.1	17.1	17.1	17.1	17.1	15.6	13.0	10.8	WPB	A234
20.0	20.0	20.0	20.0	20.0	20.0	19.8	18.3	14.8	12.0	WPC	
Castings											
13.7	13.7	13.7	13.7	13.0	12.2	11.8	11.4	10.4	8.6	WCA	A216
16.0	16.0	16.0	16.0	15.7	14.7	14.2	13.8	11.8	9.6	WCB	
16.0	16.0	16.0	16.0	16.0	16.0	15.8	14.6	11.8	9.6	WCC	
Bars and Shapes											
16.6	16.6	16.6	16.6	16.6	16.6	16.6	15.6	13.0	10.8	...	A36
18.6	18.6	18.6	18.6	18.6	18.6	18.6	16.9	13.9	11.4	...	A992

NOTES:

- (1) THIS MATERIAL IS NOT ACCEPTABLE FOR CONSTRUCTION OF PRESSURE RETAINING PARTS OF BOILER EXTERNAL PIPING — SEE FIG. 100.1.2(A.1), FIG. 100.1.2(A.2), FIG. 100.1.2(B.1), FIG. 100.1.2(B.2), AND FIG. 100.1.2(B.3).
- (2) Upon prolonged exposure to temperatures above 800°F (427°C), the carbide phase of carbon steel may be converted to graphite.
- (3) The allowable stress values given are for pipe fabricated from plate not exceeding 2¹/₂ in. in thickness.
- (4) This material shall not be used for flammable fluids. Refer to para. 105.2.1(A).
- (5) Tensile value in parentheses is expected minimum.
- (6) The 0.80 material quality factor for casting may be increased in accordance with para. 102.4.6.
- (7) The stress values for structural quality plate include a material quality factor of 0.92. The allowable stresses for A283 Grade D and A36 plate have been limited to 12.7 ksi.
- (8) These stress values are permitted only if killed or semikilled steels are used.
- (9) A254 is copper brazed (not welded) steel pipe.
- (10) For saturated steam at 250 psi (406°F), the values given for 400°F may be used.
- (11) The allowable stress values listed in MSS SP-58 for this material may be used for pipe supporting elements designed in accordance with MSS SP-58.
- (12) These values apply to material less than or equal to 1 in. thick.
- (13) These values apply to material greater than 1 in. thick.
- (14) This material is not listed in the ASME Boiler and Pressure Vessel Code, Section IX. However, weld procedures shall be qualified in accordance with the P-Number shown. See para. 127.5.1.
- (15) This material shall not be used in nominal wall thicknesses exceeding 3/4 in.
- (16) These allowable stress values are for pipe made using a butt-welded joint process. Pipe made by other processes shall not be used.

Table A-2 Low and Intermediate Alloy Steel

Spec. No.	Grade	Type or Class	Nominal Composition	P-No.	Notes	Specified Minimum Tensile, ksi	Specified Minimum Yield, ksi	E or F
Seamless Pipe and Tube								
A213	T2	...	$\frac{1}{2}\text{Cr}-\frac{1}{2}\text{Mo}$	3	...	60	30	1.00
	T5	...	$5\text{Cr}-\frac{1}{2}\text{Mo}$	5B	...	60	30	1.00
	T5b	...	$5\text{Cr}-\frac{1}{2}\text{Mo}-1\frac{1}{2}\text{Si}$	5B	...	60	30	1.00
A213	T5c	...	$5\text{Cr}-\frac{1}{2}\text{Mo}-\text{Ti}$	5B	...	60	30	1.00
	T9	...	$9\text{Cr}-1\text{Mo}$	5B	...	60	30	1.00
	T11	...	$1\frac{1}{4}\text{Cr}-\frac{1}{2}\text{Mo}$	4	...	60	30	1.00
A213	T12	...	$1\text{Cr}-\frac{1}{2}\text{Mo}$	4	...	60	30	1.00
	T21	...	$3\text{Cr}-1\text{Mo}$	5A	...	60	30	1.00
	T22	...	$2\frac{1}{4}\text{Cr}-1\text{Mo}$	5A	(5)	60	30	1.00
	T91	...	$9\text{Cr}-1\text{Mo}-\text{V}$	15E	(10)	85	60	1.00
	T91	...	$9\text{Cr}-1\text{Mo}-\text{V}$	15E	(11)	85	60	1.00
A333	3	...	$3\frac{1}{2}\text{Ni}$	9B	(1)	65	35	1.00
	4	...	$\frac{3}{4}\text{Cr}-\frac{3}{4}\text{Ni}-\text{Cu}-\text{Al}$	4	(1)	60	35	1.00
	7	...	$2\frac{1}{2}\text{Ni}$	9A	(1)	65	35	1.00
	9	...	$2\text{Ni}-1\text{Cu}$	9A	(1)	63	46	1.00
A335	P1	...	$\text{C}-\frac{1}{2}\text{Mo}$	3	(2)	55	30	1.00
	P2	...	$\frac{1}{2}\text{Cr}-\frac{1}{2}\text{Mo}$	3	...	55	30	1.00
	P5	...	$5\text{Cr}-\frac{1}{2}\text{Mo}$	5B	...	60	30	1.00
	P5b	...	$5\text{Cr}-\frac{1}{2}\text{Mo}-1\frac{1}{2}\text{Si}$	5B	...	60	30	1.00
A335	P5c	...	$5\text{Cr}-\frac{1}{2}\text{Mo}-\text{Ti}$	5B	...	60	30	1.00
	P9	...	$9\text{Cr}-1\text{Mo}$	5B	...	60	30	1.00
	P11	...	$1\frac{1}{4}\text{Cr}-\frac{1}{2}\text{Mo}-\text{Si}$	4	...	60	30	1.00
A335	P12	...	$1\text{Cr}-\frac{1}{2}\text{Mo}$	4	...	60	32	1.00
	P21	...	$3\text{Cr}-1\text{Mo}$	5A	...	60	30	1.00
	P22	...	$2\frac{1}{4}\text{Cr}-1\text{Mo}$	5A	(5)	60	30	1.00
A335	P36	1	$1.15\text{Ni}-0.65\text{Cu}-\text{Mo}-\text{Cb}$...	(12)(13)	90	64	1.00
	P36	2	$1.15\text{Ni}-0.65\text{Cu}-\text{Mo}-\text{Cb}$...	(12)(13)	95.5	66.5	1.00
	P91	...	$9\text{Cr}-1\text{Mo}-\text{V}$	15E	(10)	85	60	1.00
	P91	...	$9\text{Cr}-1\text{Mo}-\text{V}$	15E	(11)	85	60	1.00
A369	FP1	...	$\text{C}-\frac{1}{2}\text{Mo}$	3	(2)	55	30	1.00
	FP2	...	$\frac{1}{2}\text{Cr}-\frac{1}{2}\text{Mo}$	3	...	55	30	1.00
	FP5	...	$5\text{Cr}-\frac{1}{2}\text{Mo}$	5B	...	60	30	1.00
A369	FP9	...	$9\text{Cr}-1\text{Mo}$	5B	...	60	30	1.00
	FP11	...	$1\frac{1}{4}\text{Cr}-\frac{1}{2}\text{Mo}-\text{Si}$	4	...	60	30	1.00

Table A-2 Low and Intermediate Alloy Steel

Maximum Allowable Stress Values in Tension, ksi, for Metal Temperature, °F, Not Exceeding																			Spec. No.
100	200	300	400	500	600	650	700	750	800	850	900	950	1,000	1,050	1,100	1,150	1,200	Grade	
																			Seamless Pipe and Tube
17.1	17.1	17.1	17.1	16.9	16.4	16.1	15.7	15.4	14.9	14.5	13.9	9.2	5.9	T2	A213
17.1	17.1	16.6	16.5	16.4	16.2	15.9	15.6	15.1	14.5	13.8	10.9	8.0	5.8	4.2	2.9	1.8	1.0	T5	
17.1	17.1	16.6	16.5	16.4	16.2	15.9	15.6	15.1	14.5	13.8	10.9	8.0	5.8	4.2	2.9	1.8	1.0	T5b	
17.1	17.1	16.6	16.5	16.4	16.2	15.9	15.6	15.1	14.5	13.8	10.9	8.0	5.8	4.2	2.9	1.8	1.0	T5c	A213
17.1	17.1	16.6	16.5	16.4	16.2	15.9	15.6	15.1	14.5	13.8	13.0	10.6	7.4	5.0	3.3	2.2	1.5	T9	
17.1	17.1	17.1	16.8	16.2	15.7	15.4	15.1	14.8	14.4	14.0	13.6	9.3	6.3	4.2	2.8	T11	
17.1	16.8	16.5	16.5	16.5	16.3	16.0	15.8	15.5	15.3	14.9	14.5	11.3	7.2	4.5	2.8	T12	A213
17.1	17.1	16.6	16.6	16.6	16.6	16.6	16.6	16.6	16.6	16.6	16.0	12.0	9.0	7.0	5.5	4.0	...	T21	
17.1	17.1	16.6	16.6	16.6	16.6	16.6	16.6	16.6	16.6	16.6	13.6	10.8	8.0	5.7	3.8	T22	
24.3	24.3	24.3	24.2	24.1	23.7	23.4	22.9	22.2	21.3	20.3	19.1	17.8	16.3	14.0	10.3	7.0	4.3	T91	
24.3	24.3	24.3	24.2	24.1	23.7	23.4	22.9	22.2	21.3	20.3	19.1	17.8	16.3	12.9	9.6	7.0	4.3	T91	
18.6	18.6	18.6	18.6	18.6	17.5	16.7	3	A333
17.1	17.1	17.1	17.1	17.1	17.1	17.1	4	
18.6	18.6	18.6	18.6	18.6	17.5	16.7	7	
18.0	9	
15.7	15.7	15.7	15.7	15.7	15.7	15.7	15.7	15.4	14.9	14.5	P1	A335
15.7	15.7	15.7	15.7	15.7	15.7	15.7	15.7	15.4	14.9	14.5	13.9	9.2	5.9	P2	
17.1	17.1	16.6	16.5	16.4	16.2	15.9	15.6	15.1	14.5	13.8	10.9	8.0	5.8	4.2	2.9	1.8	1.0	P5	
17.1	17.1	16.6	16.5	16.4	16.2	15.9	15.6	15.1	14.5	13.8	10.9	8.0	5.8	4.2	2.9	1.8	1.0	P5b	
17.1	17.1	16.6	16.5	16.4	16.2	15.9	15.6	15.1	14.5	13.8	10.9	8.0	5.8	4.2	2.9	1.8	1.0	P5c	A335
17.1	17.1	16.6	16.5	16.4	16.2	15.9	15.6	15.1	14.5	13.8	13.0	10.6	7.4	5.0	3.3	2.2	1.5	P9	
17.1	17.1	17.1	16.8	16.2	15.7	15.4	15.1	14.8	14.4	14.0	13.6	9.3	6.3	4.2	2.8	P11	
17.1	16.8	16.5	16.5	16.5	16.3	16.0	15.8	15.5	15.3	14.9	14.5	11.3	7.2	4.5	2.8	P12	A335
17.1	17.1	16.6	16.6	16.6	16.6	16.6	16.6	16.6	16.6	16.6	16.0	12.0	9.0	7.0	5.5	4.0	...	P21	
17.1	17.1	16.6	16.6	16.6	16.6	16.6	16.6	16.6	16.6	16.6	13.6	10.8	8.0	5.7	3.8	P22	
25.7	25.7	25.1	25.1	25.1	25.1	25.1	25.1	P36	A335
27.3	27.3	26.6	26.6	26.6	26.6	26.6	26.6	P36	
24.3	24.3	24.3	24.2	24.1	23.7	23.4	22.9	22.2	21.3	20.3	19.1	17.8	16.3	14.0	10.3	7.0	4.3	P91	
24.3	24.3	24.3	24.2	24.1	23.7	23.4	22.9	22.2	21.3	20.3	19.1	17.8	16.3	12.9	9.6	7.0	4.3	P91	
15.7	15.7	15.7	15.7	15.7	15.7	15.7	15.7	15.4	14.9	14.5	FP1	A369
15.7	15.7	15.7	15.7	15.7	15.7	15.7	15.7	15.4	14.9	14.5	13.9	9.2	5.9	FP2	
17.1	17.1	16.6	16.5	16.4	16.2	15.9	15.6	15.1	14.5	13.8	10.9	8.0	5.8	4.2	2.9	1.8	1.0	FP5	
17.1	17.1	16.6	16.5	16.4	16.2	15.9	15.6	15.1	14.5	13.8	13.0	10.6	7.4	5.0	3.3	2.2	1.5	FP9	A369
17.1	17.1	17.1	16.8	16.2	15.7	15.4	15.1	14.8	14.4	14.0	13.6	9.3	6.3	4.2	2.8	FP11	

Table A-2 Low and Intermediate Alloy Steel (Cont'd)

Spec. No.	Grade	Type or Class	Nominal Composition	P-No.	Notes	Specified Minimum Tensile, ksi	Specified Minimum Yield, ksi	E or F
Seamless Pipe and Tube (Cont'd)								
A369	FP12	...	1Cr- $\frac{1}{2}$ Mo	4	...	60	32	1.00
	FP21	...	3Cr-1Mo	5A	...	60	30	1.00
	FP22	...	2 $\frac{1}{4}$ Cr-1Mo	5A	(5)	60	30	1.00
A714	V	...	2Ni-1Cu	9A	(1)	65	46	1.00
Centrifugally Cast Pipe								
A426	CP1	...	C- $\frac{1}{2}$ Mo	3	(1)(2)(3)(4)(7)	65	35	0.85
	CP2	...	$\frac{1}{2}$ Cr- $\frac{1}{2}$ Mo	3	(1)(3)(4)(7)	60	30	0.85
	CP5	...	5Cr- $\frac{1}{2}$ Mo	5B	(1)(3)(4)(7)	90	60	0.85
	CP5b	...	5Cr- $\frac{1}{2}$ Mo-Si	5B	(1)(3)(4)(7)	60	30	0.85
A426	CP9	...	9Cr-1Mo	5B	(1)(3)(4)(7)	90	60	0.85
	CP11	...	1 $\frac{1}{4}$ Cr- $\frac{1}{2}$ Mo	4	(1)(3)(4)(7)	70	40	0.85
A426	CP12	...	1Cr- $\frac{1}{2}$ Mo	4	(1)(3)(4)(7)	60	30	0.85
	CP21	...	3Cr-1Mo	5A	(1)(3)(4)(7)	60	30	0.85
	CP22	...	2 $\frac{1}{4}$ Cr-1Mo	5A	(1)(3)(4)(5)(7)	70	40	0.85
Electric Resistance Welded Pipe								
A333	3	...	3 $\frac{1}{2}$ Ni	9B	(1)	65	35	0.85
	7	...	2 $\frac{1}{2}$ Ni	9A	(1)	65	35	0.85
	9	...	2Ni-1Cu	9A	(1)	63	46	0.85
A714	V	E	2Ni-Cu	9A	(1)	65	46	0.85
Electric Fusion Welded Pipe — Filler Metal Added								
A672	L65	20,23,30,33	C- $\frac{1}{2}$ Mo	3	(1)	65	37	0.90
	L65	21,22,31,32	C- $\frac{1}{2}$ Mo	3	(1)	65	37	1.00
A672	L70	20,23,30,33	C- $\frac{1}{2}$ Mo	3	(1)	70	40	0.90
	L70	21,22,31,32	C- $\frac{1}{2}$ Mo	3	(1)	70	40	1.00
A672	L75	20,23,30,33	C- $\frac{1}{2}$ Mo	3	(1)	75	43	0.90
	L75	21,22,31,32	C- $\frac{1}{2}$ Mo	3	(1)	75	43	1.00
A691	CM-65	20,23,30,33	C- $\frac{1}{2}$ Mo	3	(1)	65	37	0.90
	CM-65	21,22,31,32	C- $\frac{1}{2}$ Mo	3	(1)	65	37	1.00
A691	CM-70	20,23,30,33	C- $\frac{1}{2}$ Mo	3	(1)	70	40	0.90
	CM-70	21,22,31,32	C- $\frac{1}{2}$ Mo	3	(1)	70	40	1.00
A691	CM-75	20,23,30,33	C- $\frac{1}{2}$ Mo	3	(1)	75	43	0.90
	CM-75	21,22,31,32	C- $\frac{1}{2}$ Mo	3	(1)	75	43	1.00
A691	$\frac{1}{2}$ CR	20,23	$\frac{1}{2}$ Cr- $\frac{1}{2}$ Mo	3	(1)(8)	55	33	0.90
	$\frac{1}{2}$ CR	21,22	$\frac{1}{2}$ Cr- $\frac{1}{2}$ Mo	3	(1)(8)	55	33	1.00
	$\frac{1}{2}$ CR	20,23,30,33,40,43	$\frac{1}{2}$ Cr- $\frac{1}{2}$ Mo	3	(1)(9)	70	45	0.90
	$\frac{1}{2}$ CR	21,22,31,32,41,42	$\frac{1}{2}$ Cr- $\frac{1}{2}$ Mo	3	(1)(9)	70	45	1.00

Table A-2 Low and Intermediate Alloy Steel (Cont'd)

Maximum Allowable Stress Values in Tension, ksi, for Metal Temperature, °F, Not Exceeding																			Spec. No.
100	200	300	400	500	600	650	700	750	800	850	900	950	1,000	1,050	1,100	1,150	1,200	Grade	
																			Seamless Pipe and Tube (Cont'd)
17.1	16.8	16.5	16.5	16.5	16.3	16.0	15.8	15.5	15.3	14.9	14.5	11.3	7.2	4.5	2.8	FP12	A369
17.1	17.1	16.6	16.6	16.6	16.6	16.6	16.6	16.6	16.6	16.6	12.0	9.0	7.0	5.5	4.0	FP21	
17.1	17.1	16.6	16.6	16.6	16.6	16.6	16.6	16.6	16.6	16.6	13.6	10.8	8.0	5.7	3.8	FP22	
18.6	V	A714
																			Centrifugally Cast Pipe
15.8	15.8	15.8	15.8	15.8	15.8	15.8	15.6	15.2	14.8	14.4	CP1	A426
14.5	14.5	14.5	14.5	14.4	13.9	13.7	13.3	13.1	12.7	12.3	11.8	7.8	5.0	CP2	
21.9	21.8	21.2	21.0	20.9	20.6	20.3	19.9	19.3	18.5	12.2	9.3	6.8	4.9	3.6	2.5	1.5	0.85	CP5	
14.6	14.5	14.1	14.0	14.0	13.8	13.5	13.3	12.9	12.4	11.8	9.3	6.8	4.9	3.6	2.5	1.5	0.85	CP5b	
21.9	21.8	21.2	21.0	20.9	20.7	20.3	19.9	19.3	18.5	17.7	14.0	9.4	6.3	4.3	2.8	1.9	1.3	CP9	A426
17.0	17.0	17.0	17.0	17.0	17.0	17.0	17.0	16.7	16.3	15.9	11.6	7.9	5.4	3.6	2.4	CP11	
14.5	14.3	14.0	13.8	13.3	12.9	12.8	12.6	12.4	12.2	11.9	11.6	9.6	6.1	3.8	2.4	CP12	A426
14.5	14.5	14.1	14.1	14.1	14.1	14.1	14.1	14.1	14.1	13.6	10.2	7.7	6.0	4.7	3.4	CP21	
17.0	17.0	16.7	16.5	16.4	16.3	16.2	16.0	15.7	15.2	14.6	13.4	9.7	6.6	4.3	2.7	CP22	
																			Electric Resistance Welded Pipe
15.8	15.8	15.8	15.8	15.8	14.9	14.2	3	A333
15.8	15.8	15.8	15.8	15.8	14.9	14.2	7	
15.3	9	
15.8	V	A714
																			Electric Fusion Welded Pipe — Filler Metal Added
16.7	16.7	16.7	16.7	16.7	16.7	16.7	16.7	16.7	16.6	16.1	L65	A672
18.6	18.6	18.6	18.6	18.6	18.6	18.6	18.6	18.6	18.4	17.9	L65	
18.0	18.0	18.0	18.0	18.0	18.0	18.0	18.0	18.0	17.9	17.4	L70	A672
20.0	20.0	20.0	20.0	20.0	20.0	20.0	20.0	20.0	20.0	19.9	19.3	L70	
19.3	19.3	19.3	19.3	19.3	19.3	19.3	19.3	19.3	19.3	18.7	L75	A672
21.4	21.4	21.4	21.4	21.4	21.4	21.4	21.4	21.4	21.4	20.7	L75	
16.7	16.7	16.7	16.7	16.7	16.7	16.7	16.7	16.7	16.6	16.1	CM-65	A691
18.6	18.6	18.6	18.6	18.6	18.6	18.6	18.6	18.6	18.4	17.9	CM-65	
18.0	18.0	18.0	18.0	18.0	18.0	18.0	18.0	18.0	17.9	17.4	CM-70	A691
20.0	20.0	20.0	20.0	20.0	20.0	20.0	20.0	20.0	20.0	19.9	19.3	CM-70	
19.3	19.3	19.3	19.3	19.3	19.3	19.3	19.3	19.3	19.3	18.7	CM-75	A691
21.4	21.4	21.4	21.4	21.4	21.4	21.4	21.4	21.4	21.4	20.7	CM-75	
14.1	14.1	14.1	14.1	14.1	14.1	14.1	14.1	14.1	14.1	13.8	12.9	8.3	5.3	½CR	A691
15.7	15.7	15.7	15.7	15.7	15.7	15.7	15.7	15.7	15.7	15.3	14.3	9.2	5.9	½CR	
18.0	18.0	18.0	18.0	18.0	18.0	18.0	18.0	18.0	18.0	17.6	16.7	8.3	5.3	½CR	
20.0	20.0	20.0	20.0	20.0	20.0	20.0	20.0	20.0	20.0	19.5	18.6	9.2	5.9	½CR	

Table A-2 Low and Intermediate Alloy Steel (Cont'd)

Spec. No.	Grade	Type or Class	Nominal Composition	P-No.	Notes	Specified Minimum Tensile, ksi	Specified Minimum Yield, ksi	E or F
Electric Fusion Welded Pipe — Filler Metal Added (Cont'd)								
A691	1CR	20,23	1Cr- $\frac{1}{2}$ Mo	4	(1)(8)	55	33	0.90
	1CR	21,22	1Cr- $\frac{1}{2}$ Mo	4	(1)(8)	55	33	1.00
	1CR	20,23,30,33,40,43	1Cr- $\frac{1}{2}$ Mo	4	(1)(9)	65	40	0.90
	1CR	21,22,31,32,41,42	1Cr- $\frac{1}{2}$ Mo	4	(1)(9)	65	40	1.00
A691	$\frac{1}{4}$ CR	20,23	$\frac{1}{4}$ Cr- $\frac{1}{2}$ Mo-Si	4	(1)(8)	60	35	0.90
	$\frac{1}{4}$ CR	21,22	$\frac{1}{4}$ Cr- $\frac{1}{2}$ Mo-Si	4	(1)(8)	60	35	1.00
	$\frac{1}{4}$ CR	20,23,30,33,40,43	$\frac{1}{4}$ Cr- $\frac{1}{2}$ Mo-Si	4	(1)(9)	75	45	0.90
	$\frac{1}{4}$ CR	21,22,31,32,41,42	$\frac{1}{4}$ Cr- $\frac{1}{2}$ Mo-Si	4	(1)(9)	75	45	1.00
A691	$\frac{2}{4}$ CR	20,23	$\frac{2}{4}$ Cr-1Mo	5A	(1)(5)(8)	60	30	0.90
	$\frac{2}{4}$ CR	21,22	$\frac{2}{4}$ Cr-1Mo	5A	(1)(5)(8)	60	30	1.00
	$\frac{2}{4}$ CR	20,23,30,33,40,43	$\frac{2}{4}$ Cr-1Mo	5A	(1)(5)(9)	75	45	0.90
	$\frac{2}{4}$ CR	21,22,31,32,41,42	$\frac{2}{4}$ Cr-1Mo	5A	(1)(5)(9)	75	45	1.00
A691	3CR	20,23	3Cr-1Mo	5A	(1)(8)	60	30	0.90
	3CR	21,22	3Cr-1Mo	5A	(1)(8)	60	30	1.00
	3CR	20,23,30,33,40,43	3Cr-1Mo	5A	(1)(9)	75	45	0.90
	3CR	21,22,31,32,41,42	3Cr-1Mo	5A	(1)(9)	75	45	1.00
A691	5CR	20,23	5Cr- $\frac{1}{2}$ Mo	5B	(1)(8)	60	30	0.90
	5CR	21,22	5Cr- $\frac{1}{2}$ Mo	5B	(1)(8)	60	30	1.00
	5CR	20,23,30,33,40,43	5Cr- $\frac{1}{2}$ Mo	5B	(1)(9)	75	45	0.90
	5CR	21,22,31,32,41,42	5Cr- $\frac{1}{2}$ Mo	5B	(1)(9)	75	45	1.00
A691	91	40,43,50,53	9Cr-1Mo-V	15E	(1)(9)	85	60	0.90
	91	41,42,51,52	9Cr-1Mo-V	15E	(1)(9)	85	60	1.00
Plate								
A387	2	1	$\frac{1}{2}$ Cr- $\frac{1}{2}$ Mo	3	...	55	33	1.00
	2	2	$\frac{1}{2}$ Cr- $\frac{1}{2}$ Mo	3	(1)	70	45	1.00
	5	1	5Cr- $\frac{1}{2}$ Mo	5B	...	60	30	1.00
	5	2	5Cr- $\frac{1}{2}$ Mo	5B	(1)	75	45	1.00
A387	11	1	$\frac{1}{4}$ Cr- $\frac{1}{2}$ Mo-Si	4	...	60	35	1.00
	11	2	$\frac{1}{4}$ Cr- $\frac{1}{2}$ Mo-Si	4	...	75	45	1.00
	12	1	1Cr- $\frac{1}{2}$ Mo	4	...	55	33	1.00
	12	2	1Cr- $\frac{1}{2}$ Mo	4	...	65	40	1.00
A387	21	1	3Cr-1Mo	5A	...	60	30	1.00
	21	2	3Cr-1Mo	5A	...	75	45	1.00
	22	1	$\frac{2}{4}$ Cr-1Mo	5A	(5)	60	30	1.00
	22	2	$\frac{2}{4}$ Cr-1Mo	5A	(5)	75	45	1.00
A387	91	2	9Cr-1Mo-V	15E	(10)	85	60	1.00
	91	2	9Cr-1Mo-V	15E	(11)	85	60	1.00

Table A-2 Low and Intermediate Alloy Steel (Cont'd)

Maximum Allowable Stress Values in Tension, ksi, for Metal Temperature, °F, Not Exceeding																			Spec. No.	
100	200	300	400	500	600	650	700	750	800	850	900	950	1,000	1,050	1,100	1,150	1,200	Grade		
Electric Fusion Welded Pipe — Filler Metal Added (Cont'd)																				
14.1	13.9	13.6	13.6	13.6	13.6	13.6	13.6	13.6	13.6	13.6	13.2	10.2	6.5	4.1	2.5	1CR	A691	
15.7	15.4	15.1	15.1	15.1	15.1	15.1	15.1	15.1	15.1	15.1	14.7	11.3	7.2	4.5	2.8	1CR		
16.7	16.4	16.1	16.1	16.1	16.1	16.1	16.1	16.1	16.1	16.1	15.6	10.2	6.5	4.1	2.5	1CR		
18.6	18.2	17.9	17.9	17.9	17.9	17.9	17.9	17.9	17.9	17.9	17.4	11.3	7.2	4.5	2.8	1CR		
15.4	15.4	15.4	15.4	15.4	15.4	15.4	15.4	15.4	15.1	14.7	12.3	8.4	5.7	3.8	2.5	1¼CR	A691	
17.1	17.1	17.1	17.1	17.1	17.1	17.1	17.1	17.1	16.8	16.4	13.7	9.3	6.3	4.2	2.8	1¼CR		
19.3	19.3	19.3	19.3	19.3	19.3	19.3	19.3	19.3	19.3	19.3	18.2	12.3	8.4	5.7	3.8	2.5	1¼CR	
21.4	21.4	21.4	21.4	21.4	21.4	21.4	21.4	21.4	21.4	20.2	13.7	9.3	6.3	4.2	2.8	1¼CR		
15.4	15.4	15.0	14.9	14.8	14.6	14.4	14.2	14.0	13.7	13.4	13.0	10.3	7.0	4.6	2.9	2¼CR	A691	
17.1	17.1	16.6	16.6	16.6	16.6	16.6	16.6	16.6	16.6	16.6	13.6	10.8	8.0	5.7	3.8	2¼CR		
19.3	19.3	18.8	18.6	18.5	18.3	18.2	18.0	17.7	17.4	16.8	14.2	10.3	7.0	4.6	2.9	2¼CR		
21.4	21.4	20.9	20.6	20.5	20.4	20.2	20.0	19.7	19.3	18.7	15.8	11.4	7.8	5.1	3.2	2¼CR		
15.4	15.4	15.0	15.0	15.0	15.0	15.0	15.0	15.0	15.0	14.4	10.8	8.1	6.3	5.0	3.6	3CR	A691	
17.1	17.1	16.6	16.6	16.6	16.6	16.6	16.6	16.6	16.6	16.0	12.0	9.0	7.0	5.5	4.0	3CR		
19.3	19.3	18.8	18.6	18.5	18.3	18.2	18.0	17.7	17.4	16.3	11.8	8.6	6.1	4.4	2.9	3CR		
21.4	21.4	20.9	20.6	20.5	20.4	20.2	20.0	19.7	19.3	18.1	13.1	9.5	6.8	4.9	3.2	3CR		
15.4	15.4	14.9	14.8	14.8	14.6	14.3	14.0	13.6	13.1	12.5	9.8	7.2	5.2	3.8	2.6	1.6	0.9	5CR	A691	
17.1	17.1	16.6	16.5	16.4	16.2	15.9	15.6	15.1	14.5	13.8	10.9	8.0	5.8	4.2	2.9	1.8	1.0	5CR		
19.3	19.2	18.7	18.5	18.5	18.2	17.9	17.5	17.0	16.4	12.9	9.8	7.2	5.2	3.8	2.6	1.6	0.9	5CR		
21.4	21.4	20.8	20.6	20.5	20.2	19.9	19.5	18.9	18.2	14.3	10.9	8.0	5.8	4.2	2.9	1.8	1.0	5CR		
21.9	21.9	21.9	21.8	21.7	21.4	21.0	20.6	20.0	19.2	18.3	17.2	16.0	14.7	12.6	9.3	6.3	3.8	91	A691	
24.3	24.3	24.3	24.2	24.1	23.7	23.4	22.9	22.2	21.3	20.3	19.1	17.8	16.3	14.0	10.3	7.0	4.3	91		
Plate																				
15.7	15.7	15.7	15.7	15.7	15.7	15.7	15.7	15.7	15.7	15.3	14.3	9.2	5.9	2	A387	
20.0	20.0	20.0	20.0	20.0	20.0	20.0	20.0	20.0	20.0	19.5	18.6	9.2	5.9	2		
17.1	17.1	16.6	16.5	16.4	16.2	15.9	15.6	15.1	14.5	13.8	10.9	8.0	5.8	4.2	2.9	1.8	1.0	5		
21.4	21.4	20.8	20.6	20.5	20.2	19.9	19.5	18.9	18.2	14.3	10.9	8.0	5.8	4.2	2.9	1.8	1.0	5		
17.1	17.1	17.1	17.1	17.1	17.1	17.1	17.1	17.1	16.8	16.4	13.7	9.3	6.3	4.2	2.8	11	A387	
21.4	21.4	21.4	21.4	21.4	21.4	21.4	21.4	21.4	21.4	20.2	13.7	9.3	6.3	4.2	2.8	11		
15.7	15.4	15.1	15.1	15.1	15.1	15.1	15.1	15.1	15.1	15.1	14.7	11.3	7.2	4.5	2.8	12		
18.6	18.2	17.9	17.9	17.9	17.9	17.9	17.9	17.9	17.9	17.9	17.4	11.3	7.2	4.5	2.8	12		
17.1	17.1	16.6	16.6	16.6	16.6	16.6	16.6	16.6	16.6	16.0	12.0	9.0	7.0	5.5	4.0	21	A387	
21.4	21.4	20.9	20.6	20.5	20.4	20.2	20.0	19.7	19.3	18.1	13.1	9.5	6.8	4.9	3.2	21		
17.1	17.1	16.6	16.6	16.6	16.6	16.6	16.6	16.6	16.6	16.6	13.6	10.8	8.0	5.7	3.8	22		
21.4	21.4	20.9	20.6	20.5	20.4	20.2	20.0	19.7	19.3	18.7	15.8	11.4	7.8	5.1	3.2	22		
24.3	24.3	24.3	24.2	24.1	23.7	23.4	22.9	22.2	21.3	20.3	19.1	17.8	16.3	14.0	10.3	7.0	4.3	91	A387	
24.3	24.3	24.3	24.2	24.1	23.7	23.4	22.9	22.2	21.3	20.3	19.1	17.8	16.3	12.9	9.6	7.0	4.3	91		

Table A-2 Low and Intermediate Alloy Steel (Cont'd)

Spec. No.	Grade	Type or Class	Nominal Composition	P-No.	Notes	Specified Minimum Tensile, ksi	Specified Minimum Yield, ksi	E or F
Forgings								
A182	F1	...	C- $\frac{1}{2}$ Mo	3	(2)	70	40	1.00
	F2	...	$\frac{1}{2}$ Cr- $\frac{1}{2}$ Mo	3	...	70	40	1.00
	F5	...	5Cr- $\frac{1}{2}$ Mo	5B	...	70	40	1.00
	F5a	...	5Cr- $\frac{1}{2}$ Mo	5B	...	90	65	1.00
A182	F11	Class 1	$1\frac{1}{4}$ Cr- $\frac{1}{2}$ Mo-Si	4	...	60	30	1.00
	F11	Class 2	$1\frac{1}{4}$ Cr- $\frac{1}{2}$ Mo-Si	4	...	70	40	1.00
	F11	Class 3	$1\frac{1}{4}$ Cr- $\frac{1}{2}$ Mo-Si	4	...	75	45	1.00
	F12	Class 1	1Cr- $\frac{1}{2}$ Mo	4	...	60	30	1.00
	F12	Class 2	1Cr- $\frac{1}{2}$ Mo	4	...	70	40	1.00
	F21	...	3Cr-1Mo	5A	...	75	45	1.00
	F22	Class 1	$2\frac{1}{4}$ Cr-1Mo	5A	(5)	60	30	1.00
	F22	Class 3	$2\frac{1}{4}$ Cr-1Mo	5A	(5)	75	45	1.00
	F36	Class 1	1.15Ni-0.65Cu-Mo-Cb	...	(12)(13)	90	64	1.00
	F36	Class 2	1.15Ni-0.65Cu-Mo-Cb	...	(12)(13)	95.5	66.5	1.00
	F9	...	9Cr-1Mo	5B	...	85	55	1.00
	F91	...	9Cr-1Mo-V	15E	...	85	60	1.00
A336	F1	...	C- $\frac{1}{2}$ Mo	3	(2)	70	40	1.00
	F5	...	5Cr- $\frac{1}{2}$ Mo	5B	...	60	36	1.00
	F5A	...	5Cr- $\frac{1}{2}$ Mo	5B	...	80	50	1.00
	F11	Class 1	$1\frac{1}{4}$ Cr- $\frac{1}{2}$ Mo-Si	4	...	60	30	1.00
	F11	Class 2	$1\frac{1}{4}$ Cr- $\frac{1}{2}$ Mo-Si	4	...	70	40	1.00
	F11	Class 3	$1\frac{1}{4}$ Cr- $\frac{1}{2}$ Mo-Si	4	...	75	45	1.00
	F12	...	1Cr- $\frac{1}{2}$ Mo	4	...	70	40	1.00
	F21	Class 1	3Cr-1Mo	5A	...	60	30	1.00
	F21	Class 3	3Cr-1Mo	5A	...	75	45	1.00
	F22	Class 1	$2\frac{1}{4}$ Cr-1Mo	5A	(5)	60	30	1.00
	F22	Class 3	$2\frac{1}{4}$ Cr-1Mo	5A	(5)	75	45	1.00
	F91	...	9Cr-1Mo-V	15E	(10)	85	60	1.00
	F91	...	9Cr-1Mo-V	15E	(11)	85	60	1.00
A350	LF3	...	$3\frac{1}{2}$ Ni	9B	(1)	70	40	1.00
	LF4	...	$\frac{3}{4}$ Cr- $\frac{3}{4}$ Ni-Cu-Al	4	(1)	60	...	1.00
	LF5	Class 1	$1\frac{1}{2}$ Ni	9A	(1)	60	30	1.00
	LF5	Class 2	$1\frac{1}{2}$ Ni	9A	(1)	70	37	1.00
	LF9	...	2Ni-1Cu	9A	(1)	63	46	1.00
Wrought Fittings (Seamless and Welded)								
A234	WP1	...	C- $\frac{1}{2}$ Mo	3	(2)	55	30	1.00
	WP5	Class 1	5Cr- $\frac{1}{2}$ Mo	5B	...	60	30	1.00
	WP5	Class 3	5Cr- $\frac{1}{2}$ Mo	5B	...	75	45	1.00
	WP9	Class 1	9Cr-1Mo	5B	...	60	30	1.00
	WP11	Class 1	$1\frac{1}{4}$ Cr- $\frac{1}{2}$ Mo	4	...	60	30	1.00
	WP11	Class 3	$1\frac{1}{4}$ Cr- $\frac{1}{2}$ Mo	4	...	75	45	1.00
	WP12	Class 1	1Cr- $\frac{1}{2}$ Mo	4	(6)	60	32	1.00
	WP12	Class 2	1Cr- $\frac{1}{2}$ Mo	4	...	70	40	1.00
A234	WP22	Class 1	$2\frac{1}{4}$ Cr-1Mo	5A	(5)	60	30	1.00
	WP22	Class 3	$2\frac{1}{4}$ Cr-1Mo	5A	(5)	75	45	1.00
	WP91	...	9Cr-1Mo-V	15E	(10)	85	60	1.00
	WP91	...	9Cr-1Mo-V	15E	(11)	85	60	1.00

Table A-2 Low and Intermediate Alloy Steel (Cont'd)

Maximum Allowable Stress Values in Tension, ksi, for Metal Temperature, °F, Not Exceeding																			Grade	Spec. No.
100	200	300	400	500	600	650	700	750	800	850	900	950	1,000	1,050	1,100	1,150	1,200			
																			Forgings	
20.0	20.0	20.0	20.0	20.0	20.0	20.0	20.0	20.0	19.9	19.3	F1	A182	
20.0	20.0	20.0	20.0	20.0	20.0	20.0	20.0	20.0	19.9	19.3	18.6	9.2	5.9	F2		
20.0	20.0	19.4	19.2	19.2	18.9	18.6	18.2	17.6	17.0	14.3	10.9	8.0	5.8	4.2	2.9	1.8	1.0	F5		
25.7	25.7	24.9	24.7	24.6	24.3	23.9	23.4	22.7	19.1	14.3	10.9	8.0	5.8	4.2	2.9	1.8	1.0	F5a		
17.1	17.1	17.1	16.8	16.2	15.7	15.4	15.1	14.8	14.4	14.0	13.6	9.3	6.3	4.2	2.8	F11	A182	
20.0	20.0	20.0	20.0	20.0	20.0	20.0	20.0	19.7	19.2	18.7	13.7	9.3	6.3	4.2	2.8	F11		
21.4	21.4	21.4	21.4	21.4	21.4	21.4	21.4	21.4	21.4	20.2	13.7	9.3	6.3	4.2	2.8	F11		
17.1	16.8	16.5	16.5	16.5	16.3	16.0	15.8	15.5	15.3	14.9	14.5	11.3	7.2	4.5	2.8	F12		
20.0	19.6	19.2	19.2	19.2	19.2	19.2	19.2	19.2	19.1	18.6	18.0	11.3	7.2	4.5	2.8	F12		
21.4	21.4	20.9	20.6	20.5	20.4	20.2	20.0	19.7	19.3	18.1	13.1	9.5	6.8	4.9	3.2	F21		
17.1	17.1	16.6	16.6	16.6	16.6	16.6	16.6	16.6	16.6	16.6	13.6	10.8	8.0	5.7	3.8	F22		
21.4	21.4	20.9	20.6	20.5	20.4	20.2	20.0	19.7	19.3	18.7	15.8	11.4	7.8	5.1	3.2	F22		
25.7	25.7	25.1	25.1	25.1	25.1	25.1	25.1	F36		
27.3	27.3	26.6	26.6	26.6	26.6	26.6	26.6	F36		
24.3	24.2	23.5	23.4	23.3	22.9	22.6	22.1	21.4	20.6	19.6	16.4	11.0	7.4	5.0	3.3	2.2	1.5	F9		
24.3	24.3	24.3	24.2	24.1	23.7	23.4	22.9	22.2	21.3	20.3	19.1	17.8	16.3	14.0	10.3	7.0	4.3	F91		
20.0	20.0	20.0	20.0	20.0	20.0	20.0	20.0	20.0	19.9	19.3	13.7	8.2	4.8	F1	A336	
17.1	17.1	16.6	16.5	16.4	16.2	15.9	15.6	15.1	14.5	13.8	10.9	8.0	5.8	4.2	2.9	1.8	1.0	F5		
22.9	22.8	22.1	22.0	21.9	21.6	21.3	20.8	20.2	19.1	14.3	10.9	8.0	5.8	4.2	2.9	1.8	1.0	F5A		
17.1	17.1	17.1	16.8	16.2	15.7	15.4	15.1	14.8	14.4	14.0	13.6	9.3	6.3	4.2	2.8	F11		
20.0	20.0	20.0	20.0	20.0	20.0	20.0	20.0	19.7	19.2	18.7	13.7	9.3	6.3	4.2	2.8	F11		
21.4	21.4	21.4	21.4	21.4	21.4	21.4	21.4	21.4	21.4	20.2	13.7	9.3	6.3	4.2	2.8	F11		
20.0	19.6	19.2	19.2	19.2	19.2	19.2	19.2	19.2	19.1	18.6	18.0	11.3	7.2	4.5	2.8	F12		
17.1	17.1	16.6	16.6	16.6	16.6	16.6	16.6	16.6	16.6	16.0	12.0	9.0	7.0	5.5	4.0	2.7	1.5	F21		
21.4	21.4	20.9	20.6	20.5	20.4	20.2	20.0	19.7	19.3	18.1	13.1	9.5	6.8	4.9	3.2	2.4	1.3	F21		
17.1	17.1	16.6	16.6	16.6	16.6	16.6	16.6	16.6	16.6	16.6	13.6	10.8	8.0	5.7	3.8	F22		
21.4	21.4	20.9	20.6	20.5	20.4	20.2	20.0	19.7	19.3	18.7	15.8	11.4	7.8	5.1	3.2	F22		
24.3	24.3	24.3	24.2	24.1	23.7	23.4	22.9	22.2	21.3	20.3	19.1	17.8	16.3	14.0	10.3	7.0	4.3	F91		
24.3	24.3	24.3	24.2	24.1	23.7	23.4	22.9	22.2	21.3	20.3	19.1	17.8	16.3	12.9	9.6	7.0	4.3	F91		
20.0	20.0	20.0	20.0	20.0	18.8	17.9	LF3	A350	
17.1	17.1	17.1	17.1	17.1	17.1	17.1	LF4		
17.1	16.5	15.7	15.3	15.3	LF5		
20.0	19.2	18.3	17.8	17.8	LF5		
18.0	LF9		
																			Wrought Fittings (Seamless and Welded)	
15.7	15.7	15.7	15.7	15.7	15.7	15.7	15.7	15.4	14.9	14.5	WP1	A234	
17.1	17.1	16.6	16.5	16.4	16.2	15.9	15.6	15.1	14.5	13.8	10.9	8.0	5.8	4.2	2.9	1.8	1.0	WP5		
21.4	21.4	20.8	20.6	20.5	20.2	19.9	19.5	18.9	18.2	14.3	10.9	8.0	5.8	4.2	2.9	1.8	1.0	WP5		
17.1	17.1	16.6	16.5	16.4	16.2	15.9	15.6	15.1	14.5	13.8	13.0	10.6	7.4	5.0	3.3	2.2	1.5	WP9		
17.1	17.1	17.1	16.8	16.2	15.7	15.4	15.1	14.8	14.4	14.0	13.6	9.3	6.3	4.2	2.8	WP11		
21.4	21.4	21.4	21.4	21.4	21.4	21.4	21.4	21.4	21.4	20.2	13.7	9.3	6.3	4.2	2.8	WP11		
17.1	16.8	16.5	16.5	16.5	16.3	16.0	15.8	15.5	15.3	14.9	14.5	11.3	7.2	4.5	2.8	WP12		
20.0	19.6	19.2	19.2	19.2	19.2	19.2	19.2	19.2	19.1	18.6	18.0	11.3	7.2	4.5	2.8	WP12		
17.1	17.1	16.6	16.6	16.6	16.6	16.6	16.6	16.6	16.6	16.6	13.6	10.8	8.0	5.7	3.8	WP22	A234	
21.4	21.4	20.9	20.6	20.5	20.4	20.2	20.0	19.7	19.3	18.7	15.8	11.4	7.8	5.1	3.2	WP22		
24.3	24.3	24.3	24.2	24.1	23.7	23.4	22.9	22.2	21.3	20.3	19.1	17.8	16.3	14.0	10.3	7.0	4.3	WP91		
24.3	24.3	24.3	24.2	24.1	23.7	23.4	22.9	22.2	21.3	20.3	19.1	17.8	16.3	12.9	9.6	7.0	4.3	WP91		

Table A-2 Low and Intermediate Alloy Steel (Cont'd)

Spec. No.	Grade	Type or Class	Nominal Composition	P-No.	Notes	Specified Minimum Tensile, ksi	Specified Minimum Yield, ksi	<i>E</i> or <i>F</i>
Castings								
A217	WC1	...	C- $\frac{1}{2}$ Mo	3	(2)(3)(4)	65	35	0.80
	WC4	...	1Ni- $\frac{1}{2}$ Cr- $\frac{1}{2}$ Mo	4	(3)(4)	70	40	0.80
	WC5	...	$\frac{3}{4}$ Ni-1Mo- $\frac{3}{4}$ Cr	4	(3)(4)	70	40	0.80
	WC6	...	1 $\frac{1}{4}$ Cr- $\frac{1}{2}$ Mo	4	(3)(4)	70	40	0.80
A217	WC9	...	2 $\frac{1}{4}$ Cr-1Mo	5A	(3)(4)	70	40	0.80
	C5	...	5Cr- $\frac{1}{2}$ Mo	5B	(3)(4)	90	60	0.80
	C12	...	9Cr-1Mo	5B	(3)(4)	90	60	0.80
	C12A	...	9Cr-1Mo-V	15E	(4)(14)	85	60	0.80

GENERAL NOTES:

- The tabulated specifications are ANSI/ASTM or ASTM. For ASME Boiler and Pressure Vessel Code applications, see related specifications in Section II of the ASME Code.
- The stress values in this Table may be interpolated to determine values for intermediate temperatures.
- The P-Numbers indicated in this Table are identical to those adopted by the ASME Boiler and Pressure Vessel Code, Section IX, except as modified by para. 127.5.
- Tensile strengths and allowable stresses shown in “ksi” are “thousands of pounds per square inch.”
- The materials listed in this Table shall not be used at design temperatures above those for which allowable stress values are given.
- The tabulated stress values are $S \times E$ (weld joint efficiency factor) or $S \times F$ (material quality factor), as applicable. Weld joint efficiency factors are shown in Table 102.4.3.
- Pressure-temperature ratings of piping components, as published in standards referenced in this Code, may be used for components meeting the requirements of those standards. The allowable stress values given in this Table are for use in designing piping components which are not manufactured in accordance with referenced standards.
- All the materials listed are classified as ferritic [see Table 104.1.2(A)].
- The tabulated stress values that are shown in italics are at temperatures in the range where creep and stress rupture strength govern the selection of stresses.
- See para. 124.1.2 for lower temperature limits.

NOTES:

- THIS MATERIAL IS NOT ACCEPTABLE FOR USE ON BOILER EXTERNAL PIPING — SEE FIG. 100.1.2(A.1), FIG. 100.1.2(A.2), FIG. 100.1.2(B.1), FIG. 100.1.2(B.2), AND FIG. 100.1.2(B.3).
- Upon prolonged exposure to temperature above 875°F, the carbide phase of carbon-molybdenum steel may be converted to graphite.
- These allowable stress values apply to normalized and tempered material only.
- The material quality factors and allowable stress values for these materials may be increased in accordance with para. 102.4.6.
- For use at temperatures above 850°F, the carbon content of the base material and, where applicable, weld filler metal shall be 0.05% or higher. See para. 124.2(D).
- If A234 Grade WP-12 fittings are made from A387 Grade 12 Class 1 plate, the allowable stress values shall be reduced by the ratio of 55 divided by 60 in the temperature range -20°F through 850°F. At 900°F through 1,100°F, the values shown may be used.
- The material quality factor for centrifugally cast pipe (0.85) is based on all surfaces being machined, after heat treatment, to a surface finish of 250 μ in. arithmetic average deviation or better.
- These allowable stress values are for pipe fabricated from ASTM A387 Class 1 plate in the annealed condition.
- These allowable stress values are for pipe fabricated from ASTM A387 Class 2 plate.
- These allowable stress values apply to thickness less than 3 in.
- These allowable stress values apply to thickness 3 in. or greater.
- Separate weld procedure and performance qualifications shall apply for both classes of this material. The postweld heat treatment shall be in accordance with para. 132.1.3.

Table A-2 Low and Intermediate Alloy Steel (Cont'd)

Maximum Allowable Stress Values in Tension, ksi, for Metal Temperature, °F, Not Exceeding																			Grade	Spec. No.
100	200	300	400	500	600	650	700	750	800	850	900	950	1,000	1,050	1,100	1,150	1,200			
																			Castings	
14.9	14.9	14.9	14.9	14.9	14.9	14.9	14.7	14.3	13.9	13.5	WC1	A217
16.0	16.0	16.0	16.0	16.0	16.0	16.0	16.0	16.0	16.0	15.4	12.0	7.4	4.7	WC4	
16.0	16.0	16.0	16.0	16.0	16.0	16.0	16.0	16.0	16.0	15.4	13.0	8.8	5.5	3.7	2.2	WC5	
16.0	16.0	16.0	16.0	16.0	16.0	16.0	16.0	15.8	15.4	15.0	11.0	7.4	5.0	3.4	2.2	WC6	
16.0	16.0	15.8	15.5	15.4	15.4	15.3	15.0	14.8	14.3	13.8	12.6	9.1	6.2	4.1	2.6	WC9	A217
20.6	20.6	19.9	19.8	19.7	19.4	19.1	18.7	18.2	15.3	11.4	8.7	6.4	4.6	3.4	2.3	1.4	0.8	...	C5	
20.6	20.6	19.9	19.8	19.7	19.4	19.1	18.7	18.2	17.4	16.6	13.1	8.8	5.9	4.0	2.6	1.8	1.2	...	C12	
19.4	19.4	18.9	18.2	17.6	17.1	16.8	16.5	16.2	15.8	15.3	14.8	14.2	11.4	9.1	7.0	5.2	3.4	...	C12A	

NOTES (Cont'd):

- (13) CAUTIONARY NOTE: Corrosion fatigue occurs by the combined actions of cyclic loading and a corrosive environment. In piping systems, corrosion fatigue is more likely to occur in portions of water systems with low strain rates (<1.0%/sec), higher temperatures [above 300°F (150°C)], and higher dissolved oxygen (>0.04 ppm), with a preference toward regions with increased local stresses. While the mechanisms of crack initiation and growth are complex and not fully understood, there is consensus that the two major factors are strain and waterside environment. Strain excursions of sufficient magnitude to fracture the protective oxide layer play a major role. In terms of the waterside environment, high levels of dissolved oxygen and pH excursions are known to be detrimental. Historically, the steels applied in these water-touched components have had the minimum specified yield strengths in the range of 27 ksi to 45 ksi (185 MPa to 310 MPa) and minimum specified tensile strengths in the range of 47 ksi to 80 ksi (325 MPa to 550 MPa). As these materials are supplanted by higher strength steels, some have concern that the higher design stresses and thinner wall thicknesses will render components more vulnerable to failures by corrosion fatigue. Thus, when employing such higher strength steels for water systems, it is desirable to use “best practices” in design by minimizing localized strain concentrations, in control of water chemistry and during lay-up by limiting dissolved oxygen and pH excursions, and in operation by conservative startup, shutdown, and turndown practices.
- (14) For additional requirements for this material, see para. 125.1.

(16)

Table A-3 Stainless Steels

Spec. No.	Type or Grade	Class	UNS Alloy No.	Nominal Composition	P-No.	Notes	Specified Minimum Tensile, ksi	Specified Minimum Yield, ksi	E or F
Seamless Pipe and Tube									
Austenitic									
A213	TP304	...	S30400	18Cr-8Ni	8	(10)	75	30	1.00
	TP304	...	S30400	18Cr-8Ni	8	(9)(10)	75	30	1.00
	TP304H	...	S30409	18Cr-8Ni	8	...	75	30	1.00
	TP304H	...	S30409	18Cr-8Ni	8	(9)	75	30	1.00
A213	TP304L	...	S30403	18Cr-8Ni	8	(1)	70	25	1.00
	TP304L	...	S30403	18Cr-8Ni	8	(1)(9)	70	25	1.00
	TP304N	...	S30451	18Cr-8Ni-N	8	(10)	80	35	1.00
	TP304N	...	S30451	18Cr-8Ni-N	8	(9)(10)	80	35	1.00
A213	S30815	21Cr-11Ni-N	8	(1)	87	45	1.00
	S30815	21Cr-11Ni-N	8	(1)(9)	87	45	1.00
A213	TP309H		S30909	23Cr-12Ni	8	(9)	75	30	1.00
	TP309H		S30909	23Cr-12Ni	8	...	75	30	1.00
	TP310H		S31009	25Cr-20Ni	8	(9)	75	30	1.00
	TP310H		S31009	25Cr-20Ni	8	...	75	30	1.00
A213	TP316	...	S31600	16Cr-12Ni-2Mo	8	(10)	75	30	1.00
	TP316	...	S31600	16Cr-12Ni-2Mo	8	(9)(10)	75	30	1.00
	TP316H	...	S31609	16Cr-12Ni-2Mo	8	...	75	30	1.00
	TP316H	...	S31609	16Cr-12Ni-2Mo	8	(9)	75	30	1.00
A213	TP316L	...	S31603	16Cr-12Ni-2Mo	8	(1)(29)	70	25	1.00
	TP316L	...	S31603	16Cr-12Ni-2Mo	8	(1)(9)(29)	70	25	1.00
	TP316N	...	S31651	16Cr-12Ni-2Mo-N	8	(10)	80	35	1.00
	TP316N	...	S31651	16Cr-12Ni-2Mo-N	8	(9)(10)	80	35	1.00
A213	TP316Ti	...	S31635	16Cr-12Ni-2Mo-Ti	8	(10)	75	30	1.00
	TP316Ti	...	S31635	16Cr-12Ni-2Mo-Ti	8	(9)(10)	75	30	1.00
	TP317	...	S31700	18Cr-13Ni-3Mo	8	(1)(10)	75	30	1.00
	TP317	...	S31700	18Cr-13Ni-3Mo	8	(1)(9)(10)	75	30	1.00
	TP317L	...	S31703	18Cr-13Ni-3Mo	8	(1)	75	30	1.00
	TP317L	...	S31703	18Cr-13Ni-3Mo	8	(1)(9)	75	30	1.00
A213	TP321	...	S32100	18Cr-10Ni-Ti	8	(10)	75	30	1.00
	TP321	...	S32100	18Cr-10Ni-Ti	8	(9)(10)	75	30	1.00
	TP321H	...	S32109	18Cr-10Ni-Ti	8	...	75	30	1.00
	TP321H	...	S32109	18Cr-10Ni-Ti	8	(9)	75	30	1.00
A213	TP347	...	S34700	18Cr-10Ni-Cb	8	(10)	75	30	1.00
	TP347	...	S34700	18Cr-10Ni-Cb	8	(9)(10)	75	30	1.00
	TP347H	...	S34709	18Cr-10Ni-Cb	8	...	75	30	1.00
	TP347H	...	S34709	18Cr-10Ni-Cb	8	(9)	75	30	1.00
A213	TP348	...	S34800	18Cr-10Ni-Cb	8	(10)	75	30	1.00
	TP348	...	S34800	18Cr-10Ni-Cb	8	(9)(10)	75	30	1.00
	TP348H	...	S34809	18Cr-10Ni-Cb	8	...	75	30	1.00
	TP348H	...	S34809	18Cr-10Ni-Cb	8	(9)	75	30	1.00
A312	N08904	44Fe-25Ni-21Cr-Mo	45	(1)	71	31	1.00
	TP304	...	S30400	18Cr-8Ni	8	(10)	75	30	1.00
	TP304	...	S30400	18Cr-8Ni	8	(9)(10)	75	30	1.00
	TP304H	...	S30409	18Cr-8Ni	8	...	75	30	1.00
	TP304H	...	S30409	18Cr-8Ni	8	(9)	75	30	1.00

Table A-3 Stainless Steels

(16)

Maximum Allowable Stress Values in Tension, ksi, for Metal Temperature, °F, Not Exceeding																			Type or Grade	Spec. No.
100	200	300	400	500	600	650	700	750	800	850	900	950	1,000	1,050	1,100	1,150	1,200			
																			Seamless Pipe and Tube Austenitic	
20.0	16.7	15.0	13.8	12.9	12.3	12.0	11.7	11.5	11.2	11.0	10.8	10.6	10.4	10.1	9.8	7.7	6.1	TP304	A213	
20.0	20.0	18.9	18.3	17.5	16.6	16.2	15.8	15.5	15.2	14.9	14.6	14.3	14.0	12.4	9.8	7.7	6.1	TP304		
20.0	16.7	15.0	13.8	12.9	12.3	12.0	11.7	11.5	11.2	11.0	10.8	10.6	10.4	10.1	9.8	7.7	6.1	TP304H		
20.0	20.0	18.9	18.3	17.5	16.6	16.2	15.8	15.5	15.2	14.9	14.6	14.3	14.0	12.4	9.8	7.7	6.1	TP304H		
16.7	14.3	12.8	11.7	10.9	10.4	10.2	10.0	9.8	9.7	TP304L	A213	
16.7	16.7	16.7	15.8	14.7	14.0	13.7	13.5	13.3	13.0	TP304L		
22.9	19.1	16.7	15.1	14.0	13.3	13.0	12.8	12.5	12.3	12.1	11.8	11.6	11.3	11.0	9.8	7.7	6.1	TP304N		
22.9	22.9	21.7	20.3	18.9	17.9	17.5	17.2	16.9	16.6	16.3	16.0	15.6	15.2	12.4	9.8	7.7	6.1	TP304N		
24.9	24.7	22.0	19.9	18.5	17.7	17.4	17.2	17.0	16.8	16.6	16.4	16.2	14.9	11.6	9.0	6.9	5.2	...	A213	
24.9	24.7	23.3	22.4	21.8	21.4	21.2	21.0	20.8	20.6	20.3	20.0	19.1	14.9	11.6	9.0	6.9	5.2	...		
20.0	20.0	20.0	20.0	19.4	18.8	18.5	18.2	18.0	17.7	17.5	17.2	16.9	13.8	10.3	7.6	5.5	4.0	TP309H	A213	
20.0	17.5	16.1	15.1	14.4	13.9	13.7	13.5	13.3	13.1	12.9	12.7	12.5	12.3	10.3	7.6	5.5	4.0	TP309H		
20.0	20.0	20.0	19.9	19.3	18.5	18.2	17.9	17.7	17.4	17.2	16.9	16.7	13.8	10.3	7.6	5.5	4.0	TP310H		
20.0	17.6	16.1	15.1	14.3	13.7	13.5	13.3	13.1	12.9	12.7	12.5	12.3	12.1	10.3	7.6	5.5	4.0	TP310H		
20.0	17.3	15.6	14.3	13.3	12.6	12.3	12.1	11.9	11.8	11.6	11.5	11.4	11.3	11.2	11.1	9.8	7.4	TP316	A213	
20.0	20.0	20.0	19.3	18.0	17.0	16.6	16.3	16.1	15.9	15.7	15.6	15.4	15.3	15.1	12.4	9.8	7.4	TP316		
20.0	17.3	15.6	14.3	13.3	12.6	12.3	12.1	11.9	11.8	11.6	11.5	11.4	11.3	11.2	11.1	9.8	7.4	TP316H		
20.0	20.0	20.0	19.3	18.0	17.0	16.6	16.3	16.1	15.9	15.7	15.6	15.4	15.3	15.1	12.4	9.8	7.4	TP316H		
16.7	14.1	12.7	11.7	10.9	10.4	10.2	10.0	9.8	9.6	9.4	9.2	9.0	8.8	8.6	8.4	8.3	6.4	TP316L	A213	
16.7	16.7	16.0	15.6	14.8	14.0	13.8	13.5	13.2	13.0	12.7	12.4	12.1	11.9	11.6	11.4	8.8	6.4	TP316L		
22.9	20.7	19.0	17.6	16.5	15.6	15.2	14.9	14.5	14.2	13.9	13.7	13.4	13.2	12.9	12.3	9.8	7.4	TP316N		
22.9	22.9	22.0	21.5	21.2	21.0	20.5	20.0	19.6	19.2	18.8	18.5	18.1	17.8	15.8	12.3	9.8	7.4	TP316N		
20.0	17.7	15.8	14.3	13.2	12.4	12.2	12.0	11.9	11.8	11.7	11.6	11.5	11.4	11.2	11.0	9.8	7.4	TP316Ti	A213	
20.0	20.0	20.0	19.4	17.8	16.8	16.5	16.2	16.0	15.9	15.8	15.7	15.5	15.3	15.1	12.3	9.8	7.4	TP316Ti		
20.0	17.3	15.6	14.3	13.3	12.6	12.3	12.1	11.9	11.8	11.6	11.5	11.4	11.3	11.2	11.1	9.8	7.4	TP317		
20.0	20.0	20.0	19.3	18.0	17.0	16.6	16.3	16.1	15.9	15.7	15.6	15.4	15.3	15.1	12.4	9.8	7.4	TP317		
20.0	17.0	15.2	14.0	13.1	12.5	12.2	12.0	11.7	11.5	11.3	TP317L		
20.0	20.0	19.6	18.9	17.7	16.9	16.5	16.2	15.8	15.5	15.2	TP317L		
20.0	18.0	16.5	15.3	14.3	13.5	13.2	13.0	12.7	12.6	12.4	12.3	12.1	12.0	9.6	6.9	5.0	3.6	TP321	A213	
20.0	20.0	19.1	18.7	18.7	18.3	17.9	17.5	17.2	16.9	16.7	16.5	16.4	16.2	9.6	6.9	5.0	3.6	TP321		
20.0	18.0	16.5	15.3	14.3	13.5	13.2	13.0	12.7	12.6	12.4	12.3	12.1	12.0	11.9	9.1	6.9	5.4	TP321H		
20.0	20.0	19.1	18.7	18.7	18.3	17.9	17.5	17.2	16.9	16.7	16.5	16.4	16.2	12.3	9.1	6.9	5.4	TP321H		
20.0	18.4	17.1	16.0	15.0	14.3	14.0	13.8	13.7	13.6	13.5	13.4	13.4	13.4	12.1	9.1	6.1	4.4	TP347	A213	
20.0	20.0	18.8	17.8	17.2	16.9	16.8	16.8	16.8	16.8	16.8	16.7	16.6	16.0	12.1	9.1	6.1	4.4	TP347		
20.0	18.4	17.1	16.0	15.0	14.3	14.0	13.8	13.7	13.6	13.5	13.4	13.4	13.4	13.4	13.3	10.5	7.9	TP347H		
20.0	20.0	18.8	17.8	17.1	16.9	16.8	16.8	16.8	16.8	16.8	16.7	16.6	16.4	16.2	14.1	10.5	7.9	TP347H		
20.0	18.4	17.1	16.0	15.0	14.3	14.0	13.8	13.7	13.6	13.5	13.4	13.4	13.4	12.1	9.1	6.1	4.4	TP348	A213	
20.0	20.0	18.8	17.8	17.2	16.9	16.8	16.8	16.8	16.8	16.8	16.7	16.6	16.0	12.1	9.1	6.1	4.4	TP348		
20.0	18.4	17.1	16.0	15.0	14.3	14.0	13.8	13.7	13.6	13.5	13.4	13.4	13.4	13.4	13.3	10.5	7.9	TP348H		
20.0	20.0	18.8	17.8	17.1	16.9	16.8	16.8	16.8	16.8	16.8	16.7	16.6	16.4	16.2	14.1	10.5	7.9	TP348H		
20.3	16.7	15.1	13.8	12.7	11.9	11.6	11.4	A312	
20.0	16.7	15.0	13.8	12.9	12.3	12.0	11.7	11.5	11.2	11.0	10.8	10.6	10.4	10.1	9.8	7.7	6.1	TP304		
20.0	20.0	18.9	18.3	17.5	16.6	16.2	15.8	15.5	15.2	14.9	14.6	14.3	14.0	12.4	9.8	7.7	6.1	TP304		
20.0	16.7	15.0	13.8	12.9	12.3	12.0	11.7	11.5	11.2	11.0	10.8	10.6	10.4	10.1	9.8	7.7	6.1	TP304H		
20.0	20.0	18.9	18.3	17.5	16.6	16.2	15.8	15.5	15.2	14.9	14.6	14.3	14.0	12.4	9.8	7.7	6.1	TP304H		

(16)

Table A-3 Stainless Steels (Cont'd)

Spec. No.	Type or Grade	Class	UNS Alloy No.	Nominal Composition	P-No.	Notes	Specified Minimum Tensile, ksi	Specified Minimum Yield, ksi	E or F
Seamless Pipe and Tube (Cont'd)									
Austenitic (Cont'd)									
A312	TP304L	...	S30403	18Cr-8Ni	8	(1)	70	25	1.00
	TP304L	...	S30403	18Cr-8Ni	8	(1)(9)	70	25	1.00
	TP304N	...	S30451	18Cr-8Ni-N	8	(10)	80	35	1.00
	TP304N	...	S30451	18Cr-8Ni-N	8	(9)(10)	80	35	1.00
A312	S30815	21Cr-11Ni-N	8	(1)	87	45	1.00
	S30815	21Cr-11Ni-N	8	(1)(9)	87	45	1.00
A312	TP309H	...	S30909	23Cr-12Ni	8	(9)	75	30	1.00
	TP309H	...	S30909	23Cr-12Ni	8	...	75	30	1.00
	TP310H	...	S31009	25Cr-20Ni	8	(9)	75	30	1.00
	TP310H	...	S31009	25Cr-20Ni	8	...	75	30	1.00
A312	TP316	...	S31600	16Cr-12Ni-2Mo	8	(10)	75	30	1.00
	TP316	...	S31600	16Cr-12Ni-2Mo	8	(9)(10)	75	30	1.00
	TP316H	...	S31609	16Cr-12Ni-2Mo	8	...	75	30	1.00
	TP316H	...	S31609	16Cr-12Ni-2Mo	8	(9)	75	30	1.00
A312	TP316L	...	S31603	16Cr-12Ni-2Mo	8	(1)(29)	70	25	1.00
	TP316L	...	S31603	16Cr-12Ni-2Mo	8	(1)(9)(29)	70	25	1.00
	TP316N	...	S31651	16Cr-12Ni-2Mo-N	8	(10)	80	35	1.00
	TP316N	...	S31651	16Cr-12Ni-2Mo-N	8	(9)(10)	80	35	1.00
A312	TP317LMN	...	S31726	19Cr-15.5Ni-4Mo	8	(1)	80	35	1.00
	TP317LMN	...	S31726	19Cr-15.5Ni-4Mo	8	(1)(9)	80	35	1.00
	TP316Ti	...	S31635	16Cr-12Ni-2Mo-Ti	8	(10)	75	30	1.00
	TP316Ti	...	S31635	16Cr-12Ni-2Mo-Ti	8	(9)(10)	75	30	1.00
A312	TP317	...	S31700	18Cr-13Ni-3Mo	8	(1)(10)	75	30	1.00
	TP317	...	S31700	18Cr-13Ni-3Mo	8	(1)(9)(10)	75	30	1.00
	TP317L	...	S31703	18Cr-13Ni-3Mo	8	...	75	30	1.00
	TP317L	...	S31703	18Cr-13Ni-3Mo	8	(9)	75	30	1.00
A312	TP321	...	S32100	18Cr-10Ni-Ti	8	(10)	75	30	1.00
	TP321	...	S32100	18Cr-10Ni-Ti	8	(9)(10)	75	30	1.00
	TP321H	...	S32109	18Cr-10Ni-Ti	8	...	75	30	1.00
	TP321H	...	S32109	18Cr-10Ni-Ti	8	(9)	75	30	1.00
A312	TP347	...	S34700	18Cr-10Ni-Cb	8	(10)	75	30	1.00
	TP347	...	S34700	18Cr-10Ni-Cb	8	(9)(10)	75	30	1.00
	TP347H	...	S34709	18Cr-10Ni-Cb	8	...	75	30	1.00
	TP347H	...	S34709	18Cr-10Ni-Cb	8	(9)	75	30	1.00
A312	TP348	...	S34800	18Cr-10Ni-Cb	8	(10)	75	30	1.00
	TP348	...	S34800	18Cr-10Ni-Cb	8	(9)(10)	75	30	1.00
	TP348H	...	S34809	18Cr-10Ni-Cb	8	...	75	30	1.00
	TP348H	...	S34809	18Cr-10Ni-Cb	8	(9)	75	30	1.00
A312	TPXM-15	...	S38100	18Cr-18Ni-2Si	8	(1)	75	30	1.00
	TPXM-15	...	S38100	18Cr-18Ni-2Si	8	(1)(9)	75	30	1.00
	TPXM-19	...	S20910	22Cr-13Ni-5Mn	8	(1)	100	55	1.00
	TPXM-19	...	S20910	22Cr-13Ni-5Mn	8	(1)(9)	100	55	1.00
	S31254	20Cr-18Ni-6Mo	8	(1)	95	45	1.00
	S31254	20Cr-18Ni-6Mo	8	(1)(9)	95	45	1.00

Table A-3 Stainless Steels (Cont'd)

(16)

Maximum Allowable Stress Values in Tension, ksi, for Metal Temperature, °F, Not Exceeding																			Type or Grade	Spec. No.
100	200	300	400	500	600	650	700	750	800	850	900	950	1,000	1,050	1,100	1,150	1,200			
																			Seamless Pipe and Tube (Cont'd) Austenitic (Cont'd)	
16.7	14.3	12.8	11.7	10.9	10.4	10.2	10.0	9.8	9.7	TP304L	A312
16.7	16.7	16.7	15.8	14.7	14.0	13.7	13.5	13.3	13.0	TP304L	
22.9	19.1	16.7	15.1	14.0	13.3	13.0	12.8	12.5	12.3	12.1	11.8	11.6	11.3	11.0	9.8	7.7	6.1	TP304N		
22.9	22.9	21.7	20.3	18.9	17.9	17.5	17.2	16.9	16.6	16.3	16.0	15.6	15.2	12.4	9.8	7.7	6.1	TP304N		
24.9	24.7	22.0	19.9	18.5	17.7	17.4	17.2	17.0	16.8	16.6	16.4	16.2	14.9	11.6	9.0	6.9	5.2	...	A312	
24.9	24.7	23.3	22.4	21.8	21.4	21.2	21.0	20.8	20.6	20.3	20.0	19.1	14.9	11.6	9.0	6.9	5.2	...		
20.0	20.0	20.0	20.0	19.4	18.8	18.5	18.2	18.0	17.7	17.5	17.2	16.9	13.8	10.3	7.6	5.5	4.0	TP309H	A312	
20.0	17.5	16.1	15.1	14.4	13.9	13.7	13.5	13.3	13.1	12.9	12.7	12.5	12.3	10.3	7.6	5.5	4.0	TP309H		
20.0	20.0	20.0	19.9	19.3	18.5	18.2	17.9	17.7	17.4	17.2	16.9	16.7	13.8	10.3	7.6	5.5	4.0	TP310H		
20.0	17.6	16.1	15.1	14.3	13.7	13.5	13.3	13.1	12.9	12.7	12.5	12.3	12.1	10.3	7.6	5.5	4.0	TP310H		
20.0	17.3	15.6	14.3	13.3	12.6	12.3	12.1	11.9	11.8	11.6	11.5	11.4	11.3	11.2	11.1	9.8	7.4	TP316	A312	
20.0	20.0	20.0	19.3	18.0	17.0	16.6	16.3	16.1	15.9	15.7	15.6	15.4	15.3	15.1	12.4	9.8	7.4	TP316		
20.0	17.3	15.6	14.3	13.3	12.6	12.3	12.1	11.9	11.8	11.6	11.5	11.4	11.3	11.2	11.1	9.8	7.4	TP316H		
20.0	20.0	20.0	19.3	18.0	17.0	16.6	16.3	16.1	15.9	15.7	15.6	15.4	15.3	15.1	12.4	9.8	7.4	TP316H		
16.7	14.2	12.7	11.7	10.9	10.4	10.2	10.0	9.8	9.6	9.4	9.2	9.0	8.8	8.6	8.4	8.3	6.4	TP316L	A312	
16.7	16.7	16.7	15.7	14.8	14.0	13.7	13.5	13.2	12.9	12.7	12.4	12.1	11.9	11.6	11.4	8.8	6.4	TP316L		
22.9	20.7	19.0	17.6	16.5	15.6	15.2	14.9	14.5	14.2	13.9	13.7	13.4	13.2	12.9	12.3	9.8	7.4	TP316N		
22.9	22.9	22.0	21.5	21.2	21.0	20.5	20.0	19.6	19.2	18.8	18.5	18.1	17.8	15.8	12.3	9.8	7.4	TP316N		
22.9	20.0	17.9	16.3	15.3	14.6	TP317LMN	A312	
22.9	21.8	20.9	20.5	20.3	19.7	TP317LMN		
20.0	17.7	15.8	14.3	13.2	12.4	12.2	12.0	11.9	11.8	11.7	11.6	11.5	11.4	11.2	11.0	9.8	7.4	TP316Ti		
20.0	20.0	20.0	19.4	17.8	16.8	16.5	16.2	16.0	15.9	15.8	15.7	15.5	15.3	15.1	12.3	9.8	7.4	TP316Ti		
20.0	17.3	15.6	14.3	13.3	12.6	12.3	12.1	11.9	11.8	11.6	11.5	11.4	11.3	11.2	11.1	9.8	7.4	TP317	A312	
20.0	20.0	20.0	19.3	18.0	17.0	16.6	16.3	16.1	15.9	15.7	15.6	15.4	15.3	15.1	12.4	9.8	7.4	TP317		
20.0	17.0	15.2	14.0	13.1	12.5	12.2	12.0	11.7	11.5	11.3	TP317L		
20.0	20.0	19.6	18.9	17.7	16.9	16.5	16.2	15.8	15.5	15.2	TP317L		
20.0	18.0	16.5	15.3	14.3	13.5	13.2	13.0	12.7	12.6	12.4	12.3	12.1	12.0	9.6	6.9	5.0	3.6	TP321	A312	
20.0	20.0	19.1	18.7	18.7	18.3	17.9	17.5	17.2	16.9	16.7	16.5	16.4	16.2	9.6	6.9	5.0	3.6	TP321		
20.0	18.0	16.5	15.3	14.3	13.5	13.2	13.0	12.7	12.6	12.4	12.3	12.1	12.0	11.9	9.1	6.9	5.4	TP321H		
20.0	20.0	19.1	18.7	18.7	18.3	17.9	17.5	17.2	16.9	16.7	16.5	16.4	16.2	12.3	9.1	6.9	5.4	TP321H		
20.0	18.4	17.1	16.0	15.0	14.3	14.0	13.8	13.7	13.6	13.5	13.4	13.4	13.4	12.1	9.1	6.1	4.4	TP347	A312	
20.0	20.0	18.8	17.8	17.2	16.9	16.8	16.8	16.8	16.8	16.8	16.7	16.6	16.0	12.1	9.1	6.1	4.4	TP347		
20.0	18.4	17.1	16.0	15.0	14.3	14.0	13.8	13.7	13.6	13.5	13.4	13.4	13.4	13.4	13.3	10.5	7.9	TP347H		
20.0	20.0	18.8	17.8	17.1	16.9	16.8	16.8	16.8	16.8	16.8	16.7	16.6	16.4	16.2	14.1	10.5	7.9	TP347H		
20.0	18.4	17.1	16.0	15.0	14.3	14.0	13.8	13.7	13.6	13.5	13.4	13.4	13.4	12.1	9.1	6.1	4.4	TP348	A312	
20.0	20.0	18.8	17.8	17.2	16.9	16.8	16.8	16.8	16.8	16.8	16.7	16.6	16.0	12.1	9.1	6.1	4.4	TP348		
20.0	18.4	17.1	16.0	15.0	14.3	14.0	13.8	13.7	13.6	13.5	13.4	13.4	13.4	13.4	13.3	10.5	7.9	TP348H		
20.0	20.0	18.8	17.8	17.1	16.9	16.8	16.8	16.8	16.8	16.8	16.7	16.6	16.4	16.2	14.1	10.5	7.9	TP348H		
20.0	16.7	15.0	13.8	12.9	12.3	12.0	11.7	11.5	11.2	11.0	10.8	10.6	10.4	TPXM-15	A312	
20.0	20.0	18.9	18.3	17.5	16.6	16.2	15.8	15.5	15.2	14.9	14.6	10.6	10.4	TPXM-15		
28.6	28.4	26.9	26.0	25.5	25.0	24.6	24.2	23.9	23.5	23.3	23.0	22.7	22.5	22.2	TPXM-19		
28.6	28.4	26.9	26.0	25.5	25.1	24.9	24.7	24.5	24.2	23.9	23.6	23.2	22.8	22.3	TPXM-19		
27.1	27.1	25.8	24.6	23.7	23.2	23.1	23.0	22.9		
27.1	24.5	21.9	20.2	19.1	18.3	18.0	17.8	17.7		

(16)

Table A-3 Stainless Steels (Cont'd)

Spec. No.	Type or Grade	Class	UNS Alloy No.	Nominal Composition	P-No.	Notes	Specified Minimum Tensile, ksi	Specified Minimum Yield, ksi	E or F
Seamless Pipe and Tube (Cont'd)									
Austenitic (Cont'd)									
A376	TP304	...	S30400	18Cr-8Ni	8	(10)	75	30	1.00
	TP304	...	S30400	18Cr-8Ni	8	(9)(10)	75	30	1.00
	TP304H	...	S30409	18Cr-8Ni	8	...	75	30	1.00
	TP304H	...	S30409	18Cr-8Ni	8	(9)	75	30	1.00
	TP304N	...	S30451	18Cr-8Ni-N	8	(10)	80	35	1.00
	TP304N	...	S30451	18Cr-8Ni-N	8	(9)(10)	80	35	1.00
A376	TP316	...	S31600	16Cr-12Ni-2Mo	8	(10)	75	30	1.00
	TP316	...	S31600	16Cr-12Ni-2Mo	8	(9)(10)	75	30	1.00
	TP316H	...	S31609	16Cr-12Ni-2Mo	8	...	75	30	1.00
	TP316H	...	S31609	16Cr-12Ni-2Mo	8	(9)	75	30	1.00
	TP316N	...	S31651	16Cr-12Ni-2Mo-N	8	(10)	80	35	1.00
	TP316N	...	S31651	16Cr-12Ni-2Mo-N	8	(9)(10)	80	35	1.00
A376	TP321	...	S32100	18Cr-10Ni-Ti	8	(10)	75	30	1.00
	TP321	...	S32100	18Cr-10Ni-Ti	8	(9)(10)	75	30	1.00
	TP321H	...	S32109	18Cr-10Ni-Ti	8	...	75	30	1.00
	TP321H	...	S32109	18Cr-10Ni-Ti	8	(9)	75	30	1.00
A376	TP347	...	S34700	18Cr-10Ni-Cb	8	(10)	75	30	1.00
	TP347	...	S34700	18Cr-10Ni-Cb	8	(9)(10)	75	30	1.00
	TP347H	...	S34709	18Cr-10Ni-Cb	8	...	75	30	1.00
	TP347H	...	S34709	18Cr-10Ni-Cb	8	(9)	75	30	1.00
A376	TP348	...	S34800	18Cr-10Ni-Cb	8	(10)	75	30	1.00
	TP348	...	S34800	18Cr-10Ni-Cb	8	(9)(10)	75	30	1.00
A789	S32550	25.5Cr-5.5Ni-3.5Mo-2Cu	10H	(1)(25)(26)	110	80	1.00
A790	S32550	25.5Cr-5.5Ni-3.5Mo-2Cu	10H	(1)(25)(26)	110	80	1.00
Ferritic/Martensitic									
A268	TP405	...	S40500	12Cr-Al	7	(3)	60	30	1.00
	TP410	...	S41000	13Cr	6	...	60	30	1.00
	TP429	...	S42900	15Cr	6	(3)	60	35	1.00
	TP430	...	S43000	17Cr	7	(3)	60	35	1.00
	TPXM-27	...	S44627	26Cr-1Mo	10I	(1)(2)	65	40	1.00
	TP446-1	...	S44600	27Cr	10I	...	70	40	1.00
	TPXM-33	...	S44626	27Cr-1Mo-Ti	10I	(2)	68	45	1.00
Ferritic/Austenitic									
A789	S31803	...	S31803	22Cr-5.5Ni-3Mo-N	10H	(1)(23)(24)	90	65	1.00
	S32101	...	S32101	21Cr-5Mn-1.5Ni-Cu-N	10H	(1)(23)(24)	94	65	1.00
	2205	...	S32205	22Cr-5.5Ni-3Mo-N	10H	(1)(23)(24)	95	70	1.00
	S32101	...	S32101	21Cr-5Mn-1.5Ni-Cu-N	10H	(1)(23)(24)	101	77	1.00
	S32750	...	S32750	25Cr-7Ni-4Mo-N	10H	(1)(22)(23)	116	80	1.00
A790	S31803	...	S31803	22Cr-5.5Ni-3Mo-N	10H	(1)(23)(24)	90	65	1.00
	S32101	...	S32101	21Cr-5Mn-1.5Ni-Cu-N	10H	(1)(23)(24)	94	65	1.00
	2205	...	S32205	22Cr-5.5Ni-3Mo-N	10H	(1)(23)(24)	95	65	1.00
	S32101	...	S32101	21Cr-5Mn-1.5Ni-Cu-N	10H	(1)(23)(24)	101	77	1.00
	S32750	...	S32750	25Cr-7Ni-4Mo-N	10H	(1)(22)(23)	116	80	1.00

Table A-3 Stainless Steels (Cont'd)

(16)

Maximum Allowable Stress Values in Tension, ksi, for Metal Temperature, °F, Not Exceeding																			Type or Grade	Spec. No.
100	200	300	400	500	600	650	700	750	800	850	900	950	1,000	1,050	1,100	1,150	1,200			
																			Seamless Pipe and Tube (Cont'd)	
																			Austenitic (Cont'd)	
20.0	16.7	15.0	13.8	12.9	12.3	12.0	11.7	11.5	11.2	11.0	10.8	10.6	10.4	10.1	9.8	7.7	6.1	TP304	A376	
20.0	20.0	18.9	18.3	17.5	16.6	16.2	15.8	15.5	15.2	14.9	14.6	14.3	14.0	12.4	9.8	7.7	6.1	TP304		
20.0	16.7	15.0	13.8	12.9	12.3	12.0	11.7	11.5	11.2	11.0	10.8	10.6	10.4	10.1	9.8	7.7	6.1	TP304H		
20.0	20.0	18.9	18.3	17.5	16.6	16.2	15.8	15.5	15.2	14.9	14.6	14.3	14.0	12.4	9.8	7.7	6.1	TP304H		
22.9	19.1	16.7	15.1	14.0	13.3	13.0	12.8	12.5	12.3	12.1	11.8	11.6	11.3	11.0	9.8	7.7	6.1	TP304N		
22.9	22.9	21.7	20.3	18.9	17.9	17.5	17.2	16.9	16.6	16.3	16.0	15.6	15.2	12.4	9.8	7.7	6.1	TP304N		
20.0	17.3	15.6	14.3	13.3	12.6	12.3	12.1	11.9	11.8	11.6	11.5	11.4	11.3	11.2	11.1	9.8	7.4	TP316	A376	
20.0	20.0	20.0	19.3	18.0	17.0	16.6	16.3	16.1	15.9	15.7	15.6	15.4	15.3	15.1	12.4	9.8	7.4	TP316		
20.0	17.3	15.6	14.3	13.3	12.6	12.3	12.1	11.9	11.8	11.6	11.5	11.4	11.3	11.2	11.1	9.8	7.4	TP316H		
20.0	20.0	20.0	19.3	18.0	17.0	16.6	16.3	16.1	15.9	15.7	15.6	15.4	15.3	15.1	12.4	9.8	7.4	TP316H		
22.9	20.7	19.0	17.6	16.5	15.6	15.2	14.9	14.5	14.2	13.9	13.7	13.4	13.2	12.9	12.3	9.8	7.4	TP316N		
22.9	22.9	22.0	21.5	21.2	21.0	20.5	20.0	19.6	19.2	18.8	18.5	18.1	17.8	15.8	12.3	9.8	7.4	TP316N		
20.0	18.0	16.5	15.3	14.3	13.5	13.2	13.0	12.7	12.6	12.4	12.3	12.1	12.0	9.6	6.9	5.0	3.6	TP321	A376	
20.0	20.0	19.1	18.7	18.7	18.3	17.9	17.5	17.2	16.9	16.7	16.5	16.4	16.2	9.6	6.9	5.0	3.6	TP321		
20.0	18.0	16.5	15.3	14.3	13.5	13.2	13.0	12.7	12.6	12.4	12.3	12.1	12.0	11.9	9.1	6.9	5.4	TP321H		
20.0	20.0	19.1	18.7	18.7	18.3	17.9	17.5	17.2	16.9	16.7	16.5	16.4	16.2	12.3	9.1	6.9	5.4	TP321H		
20.0	18.4	17.1	16.0	15.0	14.3	14.0	13.8	13.7	13.6	13.5	13.4	13.4	13.4	12.1	9.1	6.1	4.4	TP347	A376	
20.0	20.0	18.8	17.8	17.2	16.9	16.8	16.8	16.8	16.8	16.8	16.7	16.6	16.0	12.1	9.1	6.1	4.4	TP347		
20.0	18.4	17.1	16.0	15.0	14.3	14.0	13.8	13.7	13.6	13.5	13.4	13.4	13.4	13.4	13.3	10.5	7.9	TP347H		
20.0	20.0	18.8	17.8	17.1	16.9	16.8	16.8	16.8	16.8	16.8	16.7	16.6	16.4	16.2	14.1	10.5	7.9	TP347H		
20.0	18.4	17.1	16.0	15.0	14.3	14.0	13.8	13.7	13.6	13.5	13.4	13.4	13.4	12.1	9.1	6.1	4.4	TP348	A376	
20.0	20.0	18.8	17.8	17.2	16.9	16.8	16.8	16.8	16.8	16.8	16.7	16.6	16.0	12.1	9.1	6.1	4.4	TP348		
31.4	31.3	29.5	28.6	28.2	A789	
31.4	31.3	29.5	28.6	28.2	A790	
																			Ferritic/Martensitic	
17.1	17.1	16.8	16.5	16.3	15.9	15.6	15.2	TP405	A268	
17.1	17.1	16.8	16.5	16.3	15.9	15.6	15.2	TP410		
17.1	17.1	16.8	16.5	16.3	15.9	15.6	15.2	TP429		
17.1	17.1	16.8	16.5	16.3	15.9	15.6	15.2	TP430		
18.6	18.6	18.3	18.1	18.1	18.1	18.1	TPXM-27		
20.0	20.0	19.3	18.8	18.4	17.9	17.7	TP446-1		
19.4	19.4	19.3	19.0	18.8	18.4	18.1	TPXM-33		
																			Ferritic/Austenitic	
25.7	25.7	24.8	23.9	23.3	23.1	S31803	A789	
26.9	26.9	25.6	24.7	24.7	24.7	S32101		
27.1	27.1	26.2	25.2	24.6	24.3	2205		
28.9	28.9	27.5	26.5	26.5	26.5	S32101		
33.1	33.0	31.2	30.1	29.6	29.4	S32750		
25.7	25.7	24.8	23.9	23.3	23.1	S31803	A790	
26.9	26.9	25.6	24.7	24.7	24.7	S32101		
27.1	27.1	26.2	25.2	24.6	24.3	2205		
28.9	28.9	27.5	26.5	26.5	26.5	S32101		
33.1	33.0	31.2	30.1	29.6	29.4	S32750		

Table A-3 Stainless Steels (Cont'd)

Spec. No.	Type or Grade	Class	UNS Alloy No.	Nominal Composition	P-No.	Notes	Specified Minimum Tensile, ksi	Specified Minimum Yield, ksi	E or F
Centrifugally Cast Pipe									
Austenitic									
A451	CPF8	...	J92600	18Cr-8Ni	8	(1)(8)(10)(17)	70	30	0.85
	CPF8	...	J92600	18Cr-8Ni	8	(1)(8)(9)(10)(17)	70	30	0.85
	CPF8C	...	J92710	18Cr-10Ni-Cb	8	(1)(8)(10)(17)	70	30	0.85
	CPF8C	...	J92710	18Cr-10Ni-Cb	8	(1)(8)(9)(10)(17)	70	30	0.85
	CPF8M	...	J92900	18Cr-9Ni-2Mo	8	(1)(8)(13)(17)	70	30	0.85
	CPF8M	...	J92900	18Cr-9Ni-2Mo	8	(1)(8)(9)(13)(17)	70	30	0.85
A451	CPH8	...	J93400	25Cr-12Ni	8	(1)(8)(10)(17)	65	28	0.85
	CPH8	...	J93400	25Cr-12Ni	8	(1)(8)(9)(10)(17)	65	28	0.85
	CPH10	...	J93410	25Cr-12Ni	8	(1)(6)(8)(10)(17)	(70)	30	0.85
	CPH10	...	J93410	25Cr-12Ni	8	(1)(6)(8)(9)(10)(17)	(70)	30	0.85
A451	CPH20	...	J93402	25Cr-12Ni	8	(1)(6)(8)(10)(17)	(70)	30	0.85
	CPH20	...	J93402	25Cr-12Ni	8	(1)(6)(8)(9)(10)(17)	(70)	30	0.85
	CPK20	...	J94202	25Cr-20Ni	8	(1)(8)(10)(17)	65	28	0.85
	CPK20	...	J94202	25Cr-20Ni	8	(1)(8)(9)(10)(17)	65	28	0.85
Welded Pipe and Tube — Without Filler Metal									
Austenitic									
A249	TP304	...	S30400	18Cr-8Ni	8	(10)	75	30	0.85
	TP304	...	S30400	18Cr-8Ni	8	(9)(10)	75	30	0.85
	TP304H	...	S30409	18Cr-8Ni	8	...	75	30	0.85
	TP304H	...	S30409	18Cr-8Ni	8	(9)	75	30	0.85
A249	TP304L	...	S30403	18Cr-8Ni	8	(1)	70	25	0.85
	TP304L	...	S30403	18Cr-8Ni	8	(1)(9)	70	25	0.85
	TP304N	...	S30451	18Cr-8Ni-N	8	(10)	80	35	0.85
	TP304N	...	S30451	18Cr-8Ni-N	8	(9)(10)	80	35	0.85
A249	S30815	21Cr-11Ni-N	8	(1)	87	45	0.85
	S30815	21Cr-11Ni-N	8	(1)(9)	87	45	0.85
A249	TP309H	...	S30909	23Cr-12Ni	8	(9)	75	30	0.85
	TP309H	...	S30909	23Cr-12Ni	8	...	75	30	0.85
A249	TP316	...	S31600	16Cr-12Ni-2Mo	8	(10)	75	30	0.85
	TP316	...	S31600	16Cr-12Ni-2Mo	8	(9)(10)	75	30	0.85
	TP316H	...	S31609	16Cr-12Ni-2Mo	8	...	75	30	0.85
	TP316H	...	S31609	16Cr-12Ni-2Mo	8	(9)	75	30	0.85
A249	TP316L	...	S31603	16Cr-12Ni-2Mo	8	(1)(29)	70	25	0.85
	TP316L	...	S31603	16Cr-12Ni-2Mo	8	(1)(9)(29)	70	25	0.85
	TP316N	...	S31651	16Cr-12Ni-2Mo-N	8	(10)	80	35	0.85
	TP316N	...	S31651	16Cr-12Ni-2Mo-N	8	(9)(10)	80	35	0.85
A249	TP317	...	S31700	18Cr-13Ni-3Mo	8	(1)(10)	75	30	0.85
	TP317	...	S31700	18Cr-13Ni-3Mo	8	(1)(9)(10)	75	30	0.85
	TP321	...	S32100	18Cr-10Ni-Ti	8	(10)	75	30	0.85
	TP321	...	S32100	18Cr-10Ni-Ti	8	(9)(10)	75	30	0.85
	TP321H	...	S32109	18Cr-10Ni-Ti	8	...	75	30	0.85
	TP321H	...	S32109	18Cr-10Ni-Ti	8	(9)	75	30	0.85

Table A-3 Stainless Steels (Cont'd)

Maximum Allowable Stress Values in Tension, ksi, for Metal Temperature, °F, Not Exceeding																			Type or Grade	Spec. No.
100	200	300	400	500	600	650	700	750	800	850	900	950	1,000	1,050	1,100	1,150	1,200			
																			Centrifugally Cast Pipe Austenitic	
17.0	14.2	12.7	11.7	11.0	10.5	10.2	9.9	9.8	9.5	9.4	9.2	9.0	8.8	8.1	6.4	5.1	4.1	CPF8	A451	
17.0	16.1	15.0	14.5	14.4	14.1	13.8	13.4	13.2	12.9	12.7	12.4	12.2	10.4	8.1	6.4	5.1	4.1	CPF8		
17.0	14.2	12.7	11.7	11.0	10.4	10.2	10.0	9.8	9.5	9.4	9.2	9.0	8.8	8.6	7.8	5.2	3.8	CPF8C		
17.0	16.1	15.0	14.5	14.4	14.1	13.8	13.5	13.2	12.9	12.6	12.4	12.1	11.9	10.3	7.8	5.2	3.8	CPF8C		
17.0	14.6	13.2	12.1	11.3	10.7	10.4	10.3	10.1	10.0	9.9	9.8	9.7	9.6	9.5	7.6	5.9	4.6	CPF8M		
17.0	17.0	16.5	16.3	15.2	14.4	14.1	13.8	13.6	13.5	13.3	13.2	13.1	12.6	9.8	7.6	5.9	4.6	CPF8M		
15.8	13.0	12.0	11.5	11.1	10.8	10.5	10.3	10.0	9.7	9.4	9.1	8.7	8.4	7.2	5.5	4.3	3.2	CPH8	A451	
15.8	14.4	13.4	13.1	13.1	13.1	13.0	12.9	12.8	12.5	12.2	11.8	11.3	9.4	7.2	5.5	4.3	3.2	CPH8		
17.0	13.9	12.8	12.3	11.9	11.5	11.3	11.0	10.7	10.4	10.0	9.7	7.8	5.0	3.2	2.1	1.3	0.85	CPH10		
17.0	15.6	14.5	14.1	14.1	14.1	14.0	13.9	13.8	13.5	13.1	12.7	7.8	5.0	3.2	2.1	1.3	0.85	CPH10		
17.0	13.9	12.8	12.3	11.9	11.5	11.3	11.0	10.7	10.4	10.0	9.7	9.4	9.0	7.2	5.5	4.3	3.2	CPH20	A451	
17.0	15.6	14.5	14.1	14.1	14.1	14.0	13.9	13.8	13.5	13.1	12.7	12.1	9.4	7.2	5.5	4.3	3.2	CPH20		
15.8	13.0	12.0	11.5	11.1	10.8	10.5	10.3	10.0	9.7	9.4	9.1	8.7	8.4	8.1	7.2	6.2	5.1	CPK20		
15.8	14.4	13.4	13.1	13.1	13.1	13.0	12.9	12.8	12.5	12.2	11.8	11.3	9.6	8.3	7.2	6.2	5.1	CPK20		
																			Welded Pipe and Tube – Without Filler Metal Austenitic	
17.0	14.2	12.7	11.7	11.0	10.4	10.2	10.0	9.8	9.6	9.4	9.2	9.0	8.8	8.6	8.3	6.6	5.2	TP304	A249	
17.0	17.0	16.1	15.5	14.8	14.1	13.8	13.5	13.2	12.9	12.6	12.4	12.1	11.9	10.5	8.3	6.6	5.2	TP304		
17.0	14.2	12.7	11.7	11.0	10.4	10.2	10.0	9.8	9.6	9.4	9.2	9.0	8.8	8.6	8.3	6.6	5.2	TP304H		
17.0	17.0	16.1	15.5	14.8	14.1	13.8	13.5	13.2	12.9	12.6	12.4	12.1	11.9	10.5	8.3	6.6	5.2	TP304H		
14.2	12.1	10.9	9.9	9.3	8.8	8.6	8.5	8.3	8.2	TP304L	A249	
14.2	14.2	14.2	13.4	12.5	11.9	11.7	11.4	11.3	11.1	TP304L		
19.4	16.2	14.2	12.8	11.9	11.3	11.0	10.8	10.6	10.5	10.3	10.0	9.8	9.6	9.4	8.3	6.6	5.2	TP304N		
19.4	19.4	18.5	17.3	16.0	15.2	14.9	14.6	14.4	14.1	13.8	13.6	13.3	13.0	10.5	8.3	6.6	5.2	TP304N		
21.2	21.0	18.7	16.9	15.7	15.0	14.8	14.6	14.5	14.3	14.1	13.9	13.8	12.7	9.9	7.7	5.9	4.4	...	A249	
21.2	21.0	19.8	19.0	18.5	18.2	18.0	17.9	17.7	17.5	17.3	17.0	16.2	12.7	9.9	7.7	5.9	4.4	...		
17.0	17.0	17.0	17.0	16.5	15.9	15.7	15.5	15.3	15.1	14.8	14.6	14.4	11.7	8.8	6.5	4.7	3.4	TP309H	A249	
17.0	14.9	13.7	12.8	12.2	11.8	11.6	11.5	11.3	11.2	11.0	10.8	10.6	10.4	8.8	6.5	4.7	3.4	TP309H		
17.0	14.7	13.2	12.1	11.3	10.7	10.5	10.3	10.1	10.0	9.9	9.8	9.7	9.6	9.5	9.4	8.3	6.3	TP316	A249	
17.0	17.0	17.0	16.4	15.3	14.5	14.1	13.9	13.7	13.5	13.4	13.2	13.1	13.0	12.9	10.5	8.3	6.3	TP316		
17.0	14.7	13.2	12.1	11.3	10.7	10.5	10.3	10.1	10.0	9.9	9.8	9.7	9.6	9.5	9.4	8.3	6.3	TP316H		
17.0	17.0	17.0	16.4	15.3	14.5	14.1	13.9	13.7	13.5	13.4	13.2	13.1	13.0	12.9	10.5	8.3	6.3	TP316H		
14.2	12.1	10.8	9.9	9.3	8.8	8.7	8.5	8.3	8.1	8.0	7.8	7.7	7.5	7.3	7.2	7.1	5.4	TP316L	A249	
14.2	14.2	14.2	13.4	12.5	11.9	11.7	11.4	11.2	11.0	10.8	10.5	10.3	10.1	9.9	9.7	7.5	5.4	TP316L		
19.4	17.6	16.1	15.0	14.0	13.3	12.9	12.6	12.3	12.1	11.9	11.6	11.4	11.2	11.0	10.5	8.3	6.3	TP316N		
19.4	19.4	18.7	18.2	18.1	17.9	17.4	17.0	16.7	16.3	16.0	15.7	15.4	15.1	13.4	10.5	8.3	6.3	TP316N		
17.0	14.7	13.2	12.1	11.3	10.7	10.5	10.3	10.1	10.0	9.9	9.8	9.7	9.6	9.5	9.4	8.3	6.3	TP317	A249	
17.0	17.0	17.0	16.4	15.3	14.5	14.1	13.9	13.7	13.5	13.4	13.2	13.1	13.0	12.9	10.5	8.3	6.3	TP317		
17.0	15.3	14.1	13.0	12.2	11.5	11.2	11.0	10.8	10.7	10.5	10.4	10.3	10.2	8.2	5.9	4.3	3.1	TP321		
17.0	17.0	16.2	15.9	15.9	15.5	15.2	14.9	14.6	14.4	14.2	14.1	13.9	13.8	8.2	5.9	4.3	3.1	TP321		
17.0	15.3	14.1	13.0	12.2	11.5	11.2	11.0	10.8	10.7	10.5	10.4	10.3	10.2	10.1	7.7	5.9	4.6	TP321H		
17.0	17.0	16.2	15.9	15.9	15.5	15.2	14.9	14.6	14.4	14.2	14.1	13.9	13.8	10.5	7.7	5.9	4.6	TP321H		

(16)

Table A-3 Stainless Steels (Cont'd)

Spec. No.	Type or Grade	Class	UNS Alloy No.	Nominal Composition	P-No.	Notes	Specified Minimum Tensile, ksi	Specified Minimum Yield, ksi	E or F
Welded Pipe and Tube — Without Filler Metal (Cont'd)									
Austenitic (Cont'd)									
A249	TP347	...	S34700	18Cr-10Ni-Cb	8	(10)	75	30	0.85
	TP347	...	S34700	18Cr-10Ni-Cb	8	(9)(10)	75	30	0.85
	TP347H	...	S34709	18Cr-10Ni-Cb	8	...	75	30	0.85
	TP347H	...	S34709	18Cr-10Ni-Cb	8	(9)	75	30	0.85
A249	TP348	...	S34800	18Cr-10Ni-Cb	8	(10)	75	30	0.85
	TP348	...	S34800	18Cr-10Ni-Cb	8	(9)(10)	75	30	0.85
	TP348H	...	S34809	18Cr-10Ni-Cb	8	...	75	30	0.85
	TP348H	...	S34809	18Cr-10Ni-Cb	8	(9)	75	30	0.85
A249	S31254	20Cr-18Ni-6Mo	8	(1)	94	44	0.85
	S31254	20Cr-18Ni-6Mo	8	(1)(9)	94	44	0.85
A312	N08904	44Fe-25Ni-21Cr-Mo	45	(1)	71	31	0.85
	TP304	...	S30400	18Cr-8Ni	8	(10)	75	30	0.85
	TP304	...	S30400	18Cr-8Ni	8	(9)(10)	75	30	0.85
	TP304H	...	S30409	18Cr-8Ni	8	...	75	30	0.85
	TP304H	...	S30409	18Cr-8Ni	8	(9)	75	30	0.85
A312	TP304L	...	S30403	18Cr-8Ni	8	(1)	70	25	0.85
	TP304L	...	S30403	18Cr-8Ni	8	(1)(9)	70	25	0.85
	TP304N	...	S30451	18Cr-8Ni-N	8	(10)	80	35	0.85
	TP304N	...	S30451	18Cr-8Ni-N	8	(9)(10)	80	35	0.85
A312	S30815	21Cr-11Ni-N	8	(1)	87	45	0.85
	S30815	21Cr-11Ni-N	8	(1)(9)	87	45	0.85
A312	TP309H	...	S30909	23Cr-12Ni	8	(9)	75	30	0.85
	TP309H	...	S30909	23Cr-12Ni	8	...	75	30	0.85
	TP310H	...	S31009	23Cr-20Ni	8	(9)	75	30	0.85
	TP310H	...	S31009	23Cr-20Ni	8	...	75	30	0.85
A312	TP316	...	S31600	16Cr-12Ni-2Mo	8	(10)	75	30	0.85
	TP316	...	S31600	16Cr-12Ni-2Mo	8	(9)(10)	75	30	0.85
	TP316H	...	S31609	16Cr-12Ni-2Mo	8	...	75	30	0.85
	TP316H	...	S31609	16Cr-12Ni-2Mo	8	(9)	75	30	0.85
A312	TP316L	...	S31603	16Cr-12Ni-2Mo	8	(1)(29)	70	25	0.85
	TP316L	...	S31603	16Cr-12Ni-2Mo	8	(1)(9)(29)	70	25	0.85
	TP316N	...	S31651	16Cr-12Ni-2Mo-N	8	(10)	80	35	0.85
	TP316N	...	S31651	16Cr-12Ni-2Mo-N	8	(9)(10)	80	35	0.85
	TP317LMN	...	S31726	19Cr-15.5Ni-4Mo	8	(1)	80	35	0.85
	TP317LMN	...	S31726	16Cr-15.5Ni-4Mo	8	(1)(9)	80	35	0.85
A312	TP317	...	S31700	18Cr-13Ni-3Mo	8	(1)(10)	75	30	0.85
	TP317	...	S31700	18Cr-13Ni-3Mo	8	(1)(9)(10)	75	30	0.85
	TP321	...	S32100	18Cr-10Ni-Ti	8	(10)	75	30	0.85
	TP321	...	S32100	18Cr-10Ni-Ti	8	(9)(10)	75	30	0.85
	TP321H	...	S32109	18Cr-10Ni-Ti	8	...	75	30	0.85
	TP321H	...	S32109	18Cr-10Ni-Ti	8	(9)	75	30	0.85
A312	TP347	...	S34700	18Cr-10Ni-Cb	8	(10)	75	30	0.85
	TP347	...	S34700	18Cr-10Ni-Cb	8	(9)(10)	75	30	0.85
	TP347H	...	S34709	18Cr-10Ni-Cb	8	...	75	30	0.85
	TP347H	...	S34709	18Cr-10Ni-Cb	8	(9)	75	30	0.85

Table A-3 Stainless Steels (Cont'd)

(16)

Maximum Allowable Stress Values in Tension, ksi, for Metal Temperature, °F, Not Exceeding																			Type or Grade	Spec. No.
100	200	300	400	500	600	650	700	750	800	850	900	950	1,000	1,050	1,100	1,150	1,200			
Welded Pipe and Tube – Without Filler Metal (Cont'd)																				
Austenitic (Cont'd)																				
17.0	15.6	14.6	13.6	12.8	12.2	11.9	11.8	11.6	11.5	11.5	11.4	11.4	11.4	10.3	7.8	5.2	3.8	TP347	A249	
17.0	17.0	16.0	15.1	14.6	14.3	14.3	14.3	14.3	14.3	14.3	14.2	14.1	13.6	10.3	7.8	5.2	3.8	TP347		
17.0	15.6	14.6	13.6	12.8	12.2	11.9	11.8	11.6	11.5	11.5	11.4	11.4	11.4	11.4	11.3	8.9	6.7	TP347H		
17.0	17.0	16.0	15.1	14.6	14.3	14.3	14.3	14.3	14.3	14.3	14.2	14.1	14.0	13.7	12.0	8.9	6.7	TP347H		
17.0	15.6	14.6	13.6	12.8	12.2	11.9	11.8	11.6	11.5	11.5	11.4	11.4	11.4	10.3	7.8	5.2	3.8	TP348	A249	
17.0	17.0	16.0	15.1	14.6	14.3	14.3	14.3	14.3	14.3	14.3	14.2	14.1	13.6	10.3	7.8	5.2	3.8	TP348		
17.0	15.6	14.6	13.6	12.8	12.2	11.9	11.8	11.6	11.5	11.5	11.4	11.4	11.4	11.4	11.3	8.9	6.7	TP348H		
17.0	17.0	16.0	15.1	14.6	14.3	14.3	14.3	14.3	14.3	14.3	14.2	14.1	14.0	13.7	12.0	8.9	6.7	TP348H		
22.8	20.3	18.2	16.8	15.8	15.2	15.0	14.8	14.7	A249	
22.8	22.8	21.7	20.7	20.0	19.5	19.4	19.3	19.2		
17.2	14.2	12.9	11.8	10.8	10.1	9.9	9.7	A312	
17.0	14.2	12.7	11.7	11.0	10.4	10.2	10.0	9.8	9.6	9.4	9.2	9.0	8.8	8.6	8.3	6.6	5.2	TP304		
17.0	17.0	16.1	15.5	14.8	14.1	13.8	13.5	13.2	12.9	12.6	12.4	12.1	11.9	10.5	8.3	6.6	5.2	TP304		
17.0	14.2	12.7	11.7	11.0	10.4	10.2	10.0	9.8	9.6	9.4	9.2	9.0	8.8	8.6	8.3	6.6	5.2	TP304H		
17.0	17.0	16.1	15.5	14.8	14.1	13.8	13.5	13.2	12.9	12.6	12.4	12.1	11.9	10.5	8.3	6.6	5.2	TP304H		
14.2	12.1	10.9	9.9	9.3	8.8	8.6	8.5	8.3	8.2	TP304L	A312	
14.2	14.2	14.2	13.4	12.5	11.9	11.7	11.4	11.3	11.1	TP304L		
19.4	16.2	14.2	12.8	11.9	11.3	11.0	10.8	10.6	10.5	10.3	10.0	9.8	9.6	9.4	8.3	6.6	5.2	TP304N		
19.4	19.4	18.5	17.3	16.0	15.2	14.9	14.6	14.4	14.1	13.8	13.6	13.3	13.0	10.5	8.3	6.6	5.2	TP304N		
21.2	21.0	18.7	16.9	15.7	15.0	14.8	14.6	14.5	14.3	14.1	13.9	13.8	12.7	9.9	7.7	5.9	4.4	...	A312	
21.2	21.0	19.8	19.0	18.5	18.2	18.0	17.9	17.7	17.5	17.3	17.0	16.2	12.7	9.9	7.7	5.9	4.4	...		
17.0	17.0	17.0	17.0	16.5	15.9	15.7	15.5	15.3	15.1	14.8	14.6	14.4	11.7	8.8	6.5	4.7	3.4	TP309H	A312	
17.0	14.9	13.7	12.8	12.2	11.8	11.6	11.5	11.3	11.2	11.0	10.8	10.6	10.4	8.8	6.5	4.7	3.4	TP309H		
17.0	17.0	17.0	16.9	16.4	15.7	15.5	15.2	15.0	14.8	14.6	14.4	14.2	11.7	8.8	6.5	4.7	3.4	TP310H		
17.0	15.0	13.7	12.8	12.1	11.7	11.5	11.3	11.1	11.0	10.8	10.7	10.5	10.3	8.8	6.5	4.7	3.4	TP310H		
17.0	14.7	13.2	12.1	11.3	10.7	10.5	10.3	10.1	10.0	9.9	9.8	9.7	9.6	9.5	9.4	8.3	6.3	TP316	A312	
17.0	17.0	17.0	16.4	15.3	14.5	14.1	13.9	13.7	13.5	13.4	13.2	13.1	13.0	12.9	10.5	8.3	6.3	TP316		
17.0	14.7	13.2	12.1	11.3	10.7	10.5	10.3	10.1	10.0	9.9	9.8	9.7	9.6	9.5	9.4	8.3	6.3	TP316H		
17.0	17.0	17.0	16.4	15.3	14.5	14.1	13.9	13.7	13.5	13.4	13.2	13.1	13.0	12.9	10.5	8.3	6.3	TP316H		
14.2	12.1	10.8	9.9	9.3	8.8	8.7	8.5	8.3	8.1	8.0	7.8	7.7	7.5	7.3	7.2	7.1	5.4	TP316L	A312	
14.2	14.2	14.2	13.4	12.5	11.9	11.7	11.4	11.2	11.0	10.8	10.5	10.3	10.1	9.9	9.7	7.5	5.4	TP316L		
19.4	17.6	16.1	15.0	14.0	13.3	12.9	12.6	12.3	12.1	11.9	11.6	11.4	11.2	11.0	10.5	8.3	6.3	TP316N		
19.4	19.4	18.7	18.2	18.1	17.9	17.4	17.0	16.7	16.3	16.0	15.7	15.4	15.1	13.4	10.5	8.3	6.3	TP316N		
19.4	17.0	15.2	13.8	13.0	12.4	TP317LMN		
19.4	18.5	17.7	17.4	17.2	16.7	TP317LMN		
17.0	14.7	13.2	12.1	11.3	10.7	10.5	10.3	10.1	10.0	9.9	9.8	9.7	9.6	9.5	9.4	8.3	6.3	TP317	A312	
17.0	17.0	17.0	16.4	15.3	14.5	14.1	13.9	13.7	13.5	13.4	13.2	13.1	13.0	12.9	10.5	8.3	6.3	TP317		
17.0	15.3	14.1	13.0	12.2	11.5	11.2	11.0	10.8	10.7	10.5	10.4	10.3	10.2	8.2	5.9	4.3	3.1	TP321		
17.0	17.0	16.2	15.9	15.9	15.5	15.2	14.9	14.6	14.4	14.2	14.1	13.9	13.8	8.2	5.9	4.3	3.1	TP321		
17.0	15.3	14.1	13.0	12.2	11.5	11.2	11.0	10.8	10.7	10.5	10.4	10.3	10.2	10.1	7.7	5.9	4.6	TP321H		
17.0	17.0	16.2	15.9	15.9	15.5	15.2	14.9	14.6	14.4	14.2	14.1	13.9	13.8	10.5	7.7	5.9	4.6	TP321H		
17.0	15.6	14.6	13.6	12.8	12.2	11.9	11.8	11.6	11.5	11.5	11.4	11.4	11.4	10.3	7.8	5.2	3.8	TP347	A312	
17.0	17.0	16.0	15.1	14.6	14.3	14.3	14.3	14.3	14.3	14.3	14.2	14.1	13.6	10.3	7.8	5.2	3.8	TP347		
17.0	15.6	14.6	13.6	12.8	12.2	11.9	11.8	11.6	11.5	11.5	11.4	11.4	11.4	11.4	11.3	8.9	6.7	TP347H		
17.0	17.0	16.0	15.1	14.6	14.3	14.3	14.3	14.3	14.3	14.3	14.2	14.1	14.0	13.7	12.0	8.9	6.7	TP347H		

(16)

Table A-3 Stainless Steels (Cont'd)

Spec. No.	Type or Grade	Class	UNS Alloy No.	Nominal Composition	P-No.	Notes	Specified Minimum Tensile, ksi	Specified Minimum Yield, ksi	E or F
Welded Pipe and Tube — Without Filler Metal (Cont'd)									
Austenitic (Cont'd)									
A312	TP348	...	S34800	18Cr-10Ni-Cb	8	(1)(10)	75	30	0.85
	TP348	...	S34800	18Cr-10Ni-Cb	8	(1)(9)(10)	75	30	0.85
	TP348H	...	S34809	18Cr-10Ni-Cb	8	(1)	75	30	0.85
	TP348H	...	S34809	18Cr-10Ni-Cb	8	(1)(9)	75	30	0.85
A312	TPXM-15	...	S38100	18Cr-18Ni-2Si	8	(1)	75	30	0.85
	TPXM-15	...	S38100	18Cr-18Ni-2Si	8	(1)(9)	75	30	0.85
	S31254	20Cr-18Ni-6Mo	8	(1)	95	45	0.85
	S31254	20Cr-18Ni-6Mo	8	(1)(9)	95	45	0.85
A409	S30815	21Cr-11Ni-N	8	(1)	87	45	0.85
	S30815	21Cr-11Ni-N	8	(1)(9)	87	45	0.85
A789	S32550	25.5Cr-5.5Ni-3.5Mo-2Cu	10H	(1)(25)(26)	110	80	0.85
A790	S32550	25.5Cr-5.5Ni-3.5Mo-2Cu	10H	(1)(25)(26)	110	80	0.85
Ferritic/Martensitic									
A268	TP405	...	S40500	12Cr-Al	7	...	60	30	0.85
	TP410	...	S41000	13Cr	6	...	60	30	0.85
	TP429	...	S42900	15Cr	6	...	60	35	0.85
	TP430	...	S43000	17Cr	7	...	60	35	0.85
	TP446-1	...	S44600	27Cr	10I	(1)	70	40	0.85
	TPXM-27	...	S44627	26Cr-1Mo	10I	(1)(2)	65	40	0.85
	TPXM-33	...	S44626	27Cr-1Mo-Ti	10I	(2)	68	45	0.85
Ferritic/Austenitic									
A789	S31803	...	S31803	22Cr-5.5Ni-3Mo-N	10H	(1)(23)(24)	90	65	0.85
	S32101	...	S32101	21Cr-5Mn-1.5Ni-Cu-N	10H	(1)(23)(24)	94	65	0.85
	2205	...	S32205	22Cr-5.5Ni-3Mo-N	10H	(1)(23)(24)	95	70	0.85
	S32101	...	S32101	21Cr-5Mn-1.5Ni-Cu-N	10H	(1)(23)(24)	101	77	0.85
	S32750	...	S32750	25Cr-7Ni-4Mo-N	10H	(1)(22)(23)	116	80	0.85
A790	S31803	...	S31803	22Cr-5.5Ni-3Mo-N	10H	(1)(23)(24)	90	65	0.85
	S32101	...	S32101	21Cr-5Mn-1.5Ni-Cu-N	10H	(1)(23)(24)	94	65	0.85
	2205	...	S32205	22Cr-5.5Ni-3Mo-N	10H	(1)(23)(24)	95	65	0.85
	S32101	...	S32101	21Cr-5Mn-1.5Ni-Cu-N	10H	(1)(23)(24)	101	77	0.85
	S32750	...	S32750	25Cr-7Ni-4Mo-N	10H	(1)(22)(23)	116	80	0.85
Welded Pipe — Filler Metal Added									
Austenitic									
A358	304	1 & 3	S30400	18Cr-8Ni	8	(1)(10)(11)	75	30	1.00
	304	2	S30400	18Cr-8Ni	8	(1)(10)(11)	75	30	0.90
	304	1 & 3	S30400	18Cr-8Ni	8	(1)(9)(10)(11)	75	30	1.00
	304	2	S30400	18Cr-8Ni	8	(1)(9)(10)(11)	75	30	0.90
A358	304L	1 & 3	S30403	18Cr-8Ni	8	(1)	70	25	1.00
	304L	2	S30403	18Cr-8Ni	8	(1)	70	25	0.90
	304L	1 & 3	S30403	18Cr-8Ni	8	(1)(9)	70	25	1.00
	304L	2	S30403	18Cr-8Ni	8	(1)(9)	70	25	0.90
A358	304N	1 & 3	S30451	18Cr-8Ni-N	8	(1)(10)	80	35	1.00
	304N	2	S30451	18Cr-8Ni-N	8	(1)(10)	80	35	0.90
	304N	1 & 3	S30451	18Cr-8Ni-N	8	(1)(9)(10)	80	35	1.00
	304N	2	S30451	18Cr-8Ni-N	8	(1)(9)(10)	80	35	0.90

Table A-3 Stainless Steels (Cont'd)

(16)

Maximum Allowable Stress Values in Tension, ksi, for Metal Temperature, °F, Not Exceeding																			Type or Grade	Spec. No.
100	200	300	400	500	600	650	700	750	800	850	900	950	1,000	1,050	1,100	1,150	1,200			
Welded Pipe and Tube – Without Filler Metal (Cont'd)																				
Austenitic (Cont'd)																				
17.0	15.6	14.6	13.6	12.8	12.2	11.9	11.8	11.6	11.5	11.5	11.4	11.4	11.4	10.3	7.8	5.2	3.8	TP348	A312	
17.0	17.0	16.0	15.1	14.6	14.3	14.3	14.3	14.3	14.3	14.3	14.2	14.1	13.6	10.3	7.8	5.2	3.8	TP348		
17.0	15.6	14.6	13.6	12.8	12.2	11.9	11.8	11.6	11.5	11.5	11.4	11.4	11.4	11.4	11.3	8.9	6.7	TP348H		
17.0	17.0	16.0	15.1	14.6	14.3	14.3	14.3	14.3	14.3	14.3	14.2	14.1	14.0	13.7	12.0	8.9	6.7	TP348H		
17.0	14.2	12.7	11.7	11.0	10.4	10.2	10.0	9.8	9.6	9.4	9.2	9.0	8.8	TPXM-15	A312	
17.0	17.0	16.1	15.5	14.8	14.1	13.8	13.5	13.2	12.9	12.6	12.4	12.1	11.9	TPXM-15		
23.0	20.8	18.6	17.2	16.2	15.6	15.3	15.1	15.0		
23.0	23.0	21.9	20.9	20.1	19.7	19.6	19.6	19.5		
21.2	21.0	18.7	16.9	15.7	15.0	14.8	14.6	14.5	14.3	14.1	13.9	13.8	12.7	9.9	7.7	5.9	4.4	...	A409	
21.2	21.0	19.8	19.0	18.5	18.2	18.0	17.9	17.7	17.5	17.3	17.0	16.2	12.7	9.9	7.7	5.9	4.4	...		
26.7	26.6	25.1	24.3	24.0	A789	
26.7	26.6	25.1	24.3	24.0	A790	
Ferritic/Martensitic																				
14.6	14.6	14.3	14.0	13.8	13.5	13.2	12.9	TP405	A268	
14.6	14.6	14.3	14.0	13.8	13.5	13.2	12.9	TP410		
14.6	14.6	14.3	14.0	13.8	13.5	13.2	12.9	TP429		
14.6	14.6	14.3	14.0	13.8	13.5	13.2	12.9	TP430		
17.0	17.0	16.4	16.0	15.6	15.2	15.0	14.7	TP446-1		
15.8	15.8	15.5	15.4	15.4	15.4	15.4	TPXM-27		
16.5	16.5	16.4	16.2	16.0	15.7	15.4	TPXM-33		
Ferritic/Austenitic																				
21.9	21.9	21.1	20.3	19.8	19.6	S31803	A789	
22.8	22.8	21.7	21.0	21.0	21.0	S32101		
23.1	23.1	22.3	21.4	20.9	20.7	2205		
24.5	24.5	23.4	22.6	22.6	22.6	S32101		
28.2	28.0	26.5	25.6	25.2	25.0	S32750		
21.9	21.9	21.1	20.3	19.8	19.6	S31803	A790	
22.8	22.8	21.7	21.0	21.0	21.0	S32101		
23.1	23.1	22.3	21.4	20.9	20.7	2205		
24.5	24.5	23.4	22.6	22.6	22.6	S32101		
28.2	28.0	26.5	25.6	25.2	25.0	S32750		
Welded Pipe – Filler Metal Added																				
Austenitic																				
20.0	16.7	15.0	13.8	12.9	12.3	12.0	11.7	11.5	11.2	11.0	10.8	10.6	10.4	10.1	9.8	7.7	6.1	304	A358	
18.0	15.0	13.5	12.4	11.6	11.1	10.8	10.6	10.3	10.1	9.9	9.7	9.5	9.3	9.1	8.8	7.0	5.5	304		
20.0	20.0	18.9	18.3	17.5	16.6	16.2	15.8	15.5	15.2	14.9	14.6	14.3	14.0	12.4	9.8	7.7	6.1	304		
16.2	16.2	15.3	14.8	14.1	13.4	13.1	12.8	12.6	12.3	12.0	11.8	11.6	11.3	10.0	7.9	6.3	4.9	304		
16.7	14.3	12.8	11.7	10.9	10.4	10.2	10.0	9.8	9.7	304L	A358	
15.0	12.8	11.5	10.5	9.8	9.3	9.1	9.0	8.8	8.7	304L		
16.7	16.7	16.7	15.8	14.7	14.0	13.7	13.5	13.3	13.0	304L		
15.0	15.0	15.0	14.2	13.3	12.6	12.3	12.1	11.9	11.7	304L		
22.9	19.1	16.7	15.1	14.0	13.3	13.0	12.8	12.5	12.3	12.1	11.8	11.6	11.3	11.0	9.8	7.7	6.1	304N	A358	
20.6	17.2	15.0	13.5	12.6	11.9	11.7	11.5	11.3	11.1	10.9	10.6	10.4	10.2	9.9	8.8	7.0	5.5	304N		
22.9	22.9	21.7	20.3	18.9	17.9	17.5	17.2	16.9	16.6	16.3	16.0	15.6	15.2	12.4	9.8	7.7	6.1	304N		
20.6	20.6	19.6	18.3	17.0	16.1	15.8	15.5	15.2	14.9	14.7	14.4	14.0	13.7	11.2	8.8	7.0	5.5	304N		

Table A-3 Stainless Steels (Cont'd)

Spec. No.	Type or Grade	Class	UNS Alloy No.	Nominal Composition	P-No.	Notes	Specified Minimum Tensile, ksi	Specified Minimum Yield, ksi	E or F
Welded Pipe — Filler Metal Added (Cont'd)									
Austenitic (Cont'd)									
A358	...	1 & 3	S30815	21Cr-11Ni-N	8	(1)	87	45	1.00
	...	2	S30815	21Cr-11Ni-N	8	(1)	87	45	0.90
	...	1 & 3	S30815	21Cr-11Ni-N	8	(1)(9)	87	45	1.00
	...	2	S30815	21Cr-11Ni-N	8	(1)(9)	87	45	0.90
A358	309	1 & 3	S30900	23Cr-12Ni	8	(1)(10)	75	30	1.00
	309	2	S30900	23Cr-12Ni	8	(1)(10)	75	30	0.90
	309	1 & 3	S30900	23Cr-12Ni	8	(1)(9)(10)	75	30	1.00
	309	2	S30900	23Cr-12Ni	8	(1)(9)(10)	75	30	0.90
A358	310	1 & 3	S31000	25Cr-20Ni	8	(1)(10)(14)	75	30	1.00
	310	2	S31000	25Cr-20Ni	8	(1)(10)(14)	75	30	0.90
	310	1 & 3	S31000	25Cr-20Ni	8	(1)(9)(10)(14)	75	30	1.00
	310	2	S31000	25Cr-20Ni	8	(1)(9)(10)(14)	75	30	0.90
A358	310	1 & 3	S31000	25Cr-20Ni	8	(1)(10)(15)	75	30	1.00
	310	2	S31000	25Cr-20Ni	8	(1)(10)(15)	75	30	0.90
	310	1 & 3	S31000	25Cr-20Ni	8	(1)(9)(10)(15)	75	30	1.00
	310	2	S31000	25Cr-20Ni	8	(1)(9)(10)(15)	75	30	0.90
A358	316	1 & 3	S31600	16Cr-12Ni-2Mo	8	(1)(10)(11)	75	30	1.00
	316	2	S31600	16Cr-12Ni-2Mo	8	(1)(10)(11)	75	30	0.90
	316	1 & 3	S31600	16Cr-12Ni-2Mo	8	(1)(9)(10)(11)	75	30	1.00
	316	2	S31600	16Cr-12Ni-2Mo	8	(1)(9)(10)(11)	75	30	0.90
A358	316L	1 & 3	S31603	16Cr-12Ni-2Mo	8	(1)(29)	70	25	1.00
	316L	2	S31603	16Cr-12Ni-2Mo	8	(1)(29)	70	25	0.90
	316L	1 & 3	S31603	16Cr-12Ni-2Mo	8	(1)(9)(29)	70	25	1.00
	316L	2	S31603	16Cr-12Ni-2Mo	8	(1)(9)(29)	70	25	0.90
A358	316N	1 & 3	S31651	16Cr-12Ni-2Mo-N	8	(1)(10)	80	35	1.00
	316N	2	S31651	16Cr-12Ni-2Mo-N	8	(1)(10)	80	35	0.90
	316N	1 & 3	S31651	16Cr-12Ni-2Mo-N	8	(1)(9)(10)	80	35	1.00
	316N	2	S31651	16Cr-12Ni-2Mo-N	8	(1)(9)(10)	80	35	0.90
A358	321	1 & 3	S32100	18Cr-10Ni-Ti	8	(1)(10)(11)	75	30	1.00
	321	2	S32100	18Cr-10Ni-Ti	8	(1)(10)(11)	75	30	0.90
	321	1 & 3	S32100	18Cr-10Ni-Ti	8	(1)(9)(10)(11)	75	30	1.00
	321	2	S32100	18Cr-10Ni-Ti	8	(1)(9)(10)(11)	75	30	0.90
A358	347	1 & 3	S34700	18Cr-10Ni-Cb	8	(1)(10)(11)	75	30	1.00
	347	2	S34700	18Cr-10Ni-Cb	8	(1)(10)(11)	75	30	0.90
	347	1 & 3	S34700	18Cr-10Ni-Cb	8	(1)(9)(10)(11)	75	30	1.00
	347	2	S34700	18Cr-10Ni-Cb	8	(1)(9)(10)(11)	75	30	0.90

Table A-3 Stainless Steels (Cont'd)

Maximum Allowable Stress Values in Tension, ksi, for Metal Temperature, °F, Not Exceeding																			Type or Grade	Spec. No.
100	200	300	400	500	600	650	700	750	800	850	900	950	1,000	1,050	1,100	1,150	1,200			
																			Welded Pipe – Filler Metal Added (Cont'd) Austenitic (Cont'd)	
24.9	24.7	22.0	19.9	18.5	17.7	17.4	17.2	17.0	16.8	16.6	16.4	16.2	14.9	11.6	9.0	6.9	5.2	...	A358	
22.4	22.2	21.0	20.2	19.6	19.3	19.1	18.9	18.7	18.5	18.3	18.0	17.2	13.4	10.4	8.1	6.2	4.7	...		
24.9	24.7	22.0	19.9	18.5	17.7	17.4	17.2	17.0	16.8	16.6	16.4	16.2	14.9	11.6	9.0	6.9	5.2	...		
22.4	22.2	21.0	20.2	19.6	19.3	19.1	18.9	18.7	18.5	18.3	18.0	17.2	13.4	10.4	8.1	6.2	4.7	...		
20.0	17.5	16.1	15.1	14.4	13.9	13.7	13.5	13.3	13.1	12.9	12.7	12.5	9.9	7.1	5.0	3.6	2.5	309	A358	
18.0	15.8	14.5	13.6	13.0	12.5	12.3	12.1	12.0	11.8	11.6	11.5	11.3	8.9	6.4	4.5	3.2	2.3	309		
20.0	20.0	20.0	20.0	19.4	18.8	18.5	18.2	18.0	17.7	17.5	17.2	15.9	9.9	7.1	5.0	3.6	2.5	309		
18.0	18.0	18.0	18.0	17.5	16.9	16.6	16.4	16.2	15.9	15.7	15.5	14.3	8.9	6.4	4.5	3.2	2.3	309		
20.0	17.6	16.1	15.1	14.3	13.7	13.5	13.3	13.1	12.9	12.7	12.5	12.3	9.9	7.1	5.0	3.6	2.5	310	A358	
18.0	15.9	14.5	13.6	12.9	12.4	12.1	12.0	11.8	11.6	11.5	11.3	11.1	8.9	6.4	4.5	3.2	2.3	310		
20.0	20.0	20.0	19.9	19.3	18.5	18.2	17.9	17.7	17.4	17.2	16.9	15.9	9.9	7.1	5.0	3.6	2.5	310		
18.0	18.0	18.0	17.9	17.4	16.7	16.4	16.1	15.9	15.7	15.5	15.2	14.3	8.9	6.4	4.5	3.2	2.3	310		
20.0	17.6	16.1	15.1	14.3	13.7	13.5	13.3	13.1	12.9	12.7	12.5	12.3	9.9	7.1	5.0	3.6	2.5	310	A358	
18.0	15.9	14.5	13.6	12.9	12.4	12.1	12.0	11.8	11.6	11.5	11.3	11.1	8.9	6.4	4.5	3.2	2.3	310		
20.0	20.0	20.0	19.9	19.3	18.5	18.2	17.9	17.7	17.4	17.2	16.9	15.9	9.9	7.1	5.0	3.6	2.5	310		
18.0	18.0	18.0	17.9	17.4	16.7	16.4	16.1	15.9	15.7	15.5	15.2	14.3	8.9	6.4	4.5	3.2	2.3	310		
20.0	17.3	15.6	14.3	13.3	12.6	12.3	12.1	11.9	11.8	11.6	11.5	11.4	11.3	11.2	11.1	9.8	7.4	316	A358	
18.0	15.5	14.0	12.9	12.0	11.3	11.1	10.9	10.7	10.6	10.5	10.4	10.3	10.2	10.1	9.9	8.8	6.7	316		
20.0	20.0	20.0	19.3	18.0	17.0	16.6	16.3	16.1	15.9	15.7	15.6	15.4	15.3	15.1	12.4	9.8	7.4	316		
18.0	18.0	18.0	17.4	16.2	15.3	15.0	14.7	14.5	14.3	14.1	14.0	13.9	13.8	13.6	11.2	8.8	6.7	316		
16.7	14.2	12.7	11.7	10.9	10.4	10.2	10.0	9.8	9.6	9.4	9.2	9.0	8.8	8.6	8.4	8.3	6.4	316L	A358	
15.0	12.8	11.4	10.5	9.8	9.4	9.2	9.0	8.8	8.6	8.4	8.3	8.1	7.9	7.7	7.6	7.5	5.8	316L		
16.7	16.7	16.7	15.7	14.8	14.0	13.7	13.5	13.2	12.9	12.7	12.4	12.1	11.9	11.6	11.4	8.8	6.4	316L		
15.0	15.0	15.0	14.2	13.3	12.6	12.4	12.1	11.9	11.6	11.4	11.2	10.9	10.7	10.4	10.3	7.9	5.8	316L		
22.9	20.7	19.0	17.6	16.5	15.6	15.2	14.9	14.5	14.2	13.9	13.7	13.4	13.2	12.9	12.3	9.8	7.4	316N	A358	
20.6	18.6	17.1	15.8	14.8	14.0	13.7	13.4	13.1	12.8	12.6	12.3	12.1	11.9	11.6	11.1	8.8	6.7	316N		
22.9	22.9	22.0	21.5	21.2	21.0	20.5	20.0	19.6	19.2	18.8	18.5	18.1	17.8	15.8	12.3	9.8	7.4	316N		
20.6	20.6	19.8	19.3	19.1	18.9	18.5	18.0	17.7	17.3	16.9	16.6	16.3	16.0	14.2	11.1	8.8	6.7	316N		
20.0	18.0	16.5	15.3	14.3	13.5	13.2	13.0	12.7	12.6	12.4	12.3	12.1	12.0	9.6	6.9	5.0	3.6	321	A358	
18.0	16.2	14.9	13.8	12.9	12.2	11.9	11.7	11.5	11.3	11.2	11.0	10.9	10.8	8.6	6.2	4.5	3.2	321		
20.0	20.0	19.1	18.7	18.7	18.3	17.9	17.5	17.2	16.9	16.7	16.5	16.4	16.2	9.6	6.9	5.0	3.6	321		
18.0	18.0	17.2	16.8	16.8	16.5	16.1	15.8	15.5	15.3	15.1	14.9	14.7	14.6	8.6	6.2	4.5	3.2	321		
20.0	18.4	17.1	16.0	15.0	14.3	14.0	13.8	13.7	13.6	13.5	13.4	13.4	13.4	12.1	9.1	6.1	4.4	347	A358	
18.0	16.6	15.4	14.4	13.5	12.9	12.6	12.4	12.3	12.2	12.1	12.1	12.1	12.1	10.9	8.2	5.5	4.0	347		
20.0	20.0	18.8	17.8	17.2	16.9	16.8	16.8	16.8	16.8	16.8	16.7	16.6	16.0	12.1	9.1	6.1	4.4	347		
18.0	18.0	16.9	16.0	15.4	15.2	15.1	15.1	15.1	15.1	15.1	15.0	14.9	14.4	10.9	8.2	5.5	4.0	347		

Table A-3 Stainless Steels (Cont'd)

Spec. No.	Type or Grade	Class	UNS Alloy No.	Nominal Composition	P-No.	Notes	Specified Minimum Tensile, ksi	Specified Minimum Yield, ksi	E or F
Welded Pipe — Filler Metal Added (Cont'd)									
Austenitic (Cont'd)									
A358	348	1 & 3	S34800	18Cr-10Ni-Cb	8	(1)(10)(11)	75	30	1.00
	348	2	S34800	18Cr-10Ni-Cb	8	(1)(10)(11)	75	30	0.90
	348	1 & 3	S34800	18Cr-10Ni-Cb	8	(1)(9)(10)(11)	75	30	1.00
	348	2	S34800	18Cr-10Ni-Cb	8	(1)(9)(10)(11)	75	30	0.90
A358	...	1 & 3	S31254	20Cr-18Ni-6Mo	8	(1)	95	45	1.00
	...	2	S31254	20Cr-18Ni-6Mo	8	(1)	95	45	0.90
	...	1 & 3	S31254	20Cr-18Ni-6Mo	8	(1)(9)	95	45	1.00
	...	2	S31254	20Cr-18Ni-6Mo	8	(1)(9)	95	45	0.90
A358	...	1 & 3	S31254	20Cr-18Ni-6Mo	8	(1)	100	45	1.00
	...	2	S31254	20Cr-18Ni-6Mo	8	(1)	100	45	0.90
	...	1 & 3	S31254	20Cr-18Ni-6Mo	8	(1)(9)	100	45	1.00
	...	2	S31254	20Cr-18Ni-6Mo	8	(1)(9)	100	45	0.90
A409	TP304	...	S30400	18Cr-8Ni	8	(1)(10)(19)	75	30	1.00
	TP304	...	S30400	18Cr-8Ni	8	(1)(10)(20)	75	30	0.90
	TP304	...	S30400	18Cr-8Ni	8	(1)(10)(21)	75	30	0.80
	TP304	...	S30400	18Cr-8Ni	8	(1)(9)(10)(19)	75	30	1.00
	TP304	...	S30400	18Cr-8Ni	8	(1)(9)(10)(20)	75	30	0.90
	TP304	...	S30400	18Cr-8Ni	8	(1)(9)(10)(21)	75	30	0.80
A409	TP304L	...	S30403	18Cr-8Ni	8	(1)(19)	70	25	1.00
	TP304L	...	S30403	18Cr-8Ni	8	(1)(20)	70	25	0.90
	TP304L	...	S30403	18Cr-8Ni	8	(1)(21)	70	25	0.80
	TP304L	...	S30403	18Cr-8Ni	8	(1)(9)(19)	70	25	1.00
	TP304L	...	S30403	18Cr-8Ni	8	(1)(9)(20)	70	25	0.90
	TP304L	...	S30403	18Cr-8Ni	8	(1)(9)(21)	70	25	0.80
A409	S30815	21Cr-11Ni-N	8	(1)(19)	87	45	1.00
	S30815	21Cr-11Ni-N	8	(1)(20)	87	45	0.90
	S30815	21Cr-11Ni-N	8	(1)(21)	87	45	0.80
	S30815	21Cr-11Ni-N	8	(1)(9)(19)	87	45	1.00
	S30815	21Cr-11Ni-N	8	(1)(9)(20)	87	45	0.90
	S30815	21Cr-11Ni-N	8	(1)(9)(21)	87	45	0.80
A409	TP316	...	S31600	16Cr-12Ni-2Mo	8	(1)(10)(19)	75	30	1.00
	TP316	...	S31600	16Cr-12Ni-2Mo	8	(1)(10)(20)	75	30	0.90
	TP316	...	S31600	16Cr-12Ni-2Mo	8	(1)(10)(21)	75	30	0.80
	TP316	...	S31600	16Cr-12Ni-2Mo	8	(1)(9)(10)(19)	75	30	1.00
	TP316	...	S31600	16Cr-12Ni-2Mo	8	(1)(9)(10)(20)	75	30	0.90
	TP316	...	S31600	16Cr-12Ni-2Mo	8	(1)(9)(10)(21)	75	30	0.80

Table A-3 Stainless Steels (Cont'd)

Maximum Allowable Stress Values in Tension, ksi, for Metal Temperature, °F, Not Exceeding																			Type or Grade	Spec. No.
100	200	300	400	500	600	650	700	750	800	850	900	950	1,000	1,050	1,100	1,150	1,200			
																			Welded Pipe – Filler Metal Added (Cont'd) Austenitic (Cont'd)	
20.0	18.4	17.1	16.0	15.0	14.3	14.0	13.8	13.7	13.6	13.5	13.4	13.4	13.4	12.1	9.1	6.1	4.4	348	A358	
18.0	16.6	15.4	14.4	13.5	12.9	12.6	12.4	12.3	12.2	12.1	12.1	12.1	12.1	10.9	8.2	5.5	4.0	348		
20.0	20.0	18.8	17.8	17.2	16.9	16.8	16.8	16.8	16.8	16.8	16.7	16.6	16.0	12.1	9.1	6.1	4.4	348		
18.0	18.0	16.9	16.0	15.4	15.2	15.1	15.1	15.1	15.1	15.1	15.0	14.9	14.4	10.9	8.2	5.5	4.0	348		
27.1	24.5	21.9	20.2	19.1	18.3	18.0	17.8	17.7	A358	
24.4	22.1	19.7	18.2	17.2	16.5	16.2	16.0	15.9		
27.1	27.1	25.8	24.6	23.7	23.2	23.1	23.0	22.9		
24.4	24.4	23.2	22.1	21.3	20.9	20.8	20.7	20.6		
28.6	24.5	21.9	20.2	19.1	18.3	18.0	17.8	17.7	A358	
25.7	22.1	19.7	18.2	17.2	16.5	16.2	16.0	15.9		
28.6	28.6	27.2	25.9	25.0	24.4	24.3	24.1	23.9		
25.7	25.7	24.5	23.3	22.5	22.0	21.9	21.7	21.5		
20.0	16.7	15.0	13.8	12.9	12.3	12.0	11.7	11.5	11.2	11.0	10.8	10.6	10.4	10.1	9.8	7.7	6.1	TP304	A409	
18.0	15.0	13.5	12.4	11.6	11.1	10.8	10.6	10.3	10.1	9.9	9.7	9.5	9.3	9.1	8.8	7.0	5.5	TP304		
16.0	13.3	12.0	11.0	10.4	9.8	9.6	9.4	9.2	9.0	8.8	8.6	8.5	8.3	8.1	7.8	6.2	4.9	TP304		
20.0	20.0	18.9	18.3	17.5	16.6	16.2	15.8	15.5	15.2	14.9	14.6	14.3	14.0	12.4	9.8	7.7	6.1	TP304		
18.0	18.0	17.0	16.5	15.7	14.9	14.6	14.3	13.9	13.7	13.4	13.1	12.8	12.6	11.2	8.8	7.0	5.5	TP304		
16.0	16.0	15.1	14.6	14.0	13.3	13.0	12.7	12.4	12.1	11.9	11.7	11.4	11.2	9.9	7.8	6.2	4.9	TP304		
16.7	14.3	12.8	11.7	10.9	10.4	10.2	10.0	9.8	9.7	TP304L	A409	
15.0	12.8	11.5	10.5	9.8	9.3	9.1	9.0	8.8	8.7	TP304L		
13.3	11.4	10.2	9.4	8.7	8.3	8.1	8.0	7.9	7.7	TP304L		
16.7	16.7	16.7	15.8	14.7	14.0	13.7	13.5	13.3	13.0	TP304L		
15.0	15.0	15.0	14.2	13.3	12.6	12.3	12.1	11.9	11.7	TP304L		
13.3	13.3	13.3	12.6	11.8	11.2	11.0	10.8	10.6	10.4	TP304L		
24.9	24.7	22.0	19.9	18.5	17.7	17.4	17.2	17.0	16.8	16.6	16.4	16.2	14.9	11.6	9.0	6.9	5.2	...	A409	
22.4	22.2	19.8	17.9	16.7	15.9	15.7	15.5	15.3	15.1	14.9	14.8	14.6	13.4	10.4	8.1	6.2	4.7	...		
19.9	19.8	17.6	15.9	14.8	14.2	13.9	13.8	13.6	13.4	13.3	13.1	13.0	11.9	9.3	7.2	5.5	4.2	...		
24.9	24.7	23.3	22.4	21.8	21.4	21.2	21.0	20.8	20.6	20.3	20.0	19.1	14.9	11.6	9.0	6.9	5.2	...		
22.4	22.2	21.0	20.2	19.6	19.3	19.1	18.9	18.7	18.5	18.3	18.0	17.2	13.4	10.4	8.1	6.2	4.7	...		
19.9	19.8	18.6	17.9	17.4	17.1	17.0	16.8	16.6	16.5	16.2	16.0	15.3	11.9	9.3	7.2	5.5	4.2	...		
20.0	17.3	15.6	14.3	13.3	12.6	12.3	12.1	11.9	11.8	11.6	11.5	11.4	11.3	11.2	11.1	9.8	7.4	TP316	A409	
18.0	15.5	14.0	12.9	12.0	11.3	11.1	10.9	10.7	10.6	10.5	10.4	10.3	10.2	10.1	9.9	8.8	6.7	TP316		
16.0	13.8	12.5	11.4	10.6	10.1	9.9	9.7	9.5	9.4	9.3	9.2	9.1	9.1	9.0	8.8	7.8	5.9	TP316		
20.0	20.0	20.0	19.3	18.0	17.0	16.6	16.3	16.1	15.9	15.7	15.6	15.4	15.3	15.1	12.4	9.8	7.4	TP316		
18.0	18.0	18.0	17.4	16.2	15.3	15.0	14.7	14.5	14.3	14.1	14.0	13.9	13.8	13.6	11.2	8.8	6.7	TP316		
16.0	16.0	16.0	15.4	14.4	13.6	13.3	13.1	12.9	12.7	12.6	12.5	12.3	12.2	12.1	9.9	7.8	5.9	TP316		

(16)

Table A-3 Stainless Steels (Cont'd)

Spec. No.	Type or Grade	Class	UNS Alloy No.	Nominal Composition	P-No.	Notes	Specified Minimum Tensile, ksi	Specified Minimum Yield, ksi	E or F
Welded Pipe — Filler Metal Added (Cont'd)									
Austenitic (Cont'd)									
A409	TP316L	...	S31603	16Cr-12Ni-2Mo	8	(1)(19)(29)	70	25	1.00
	TP316L	...	S31603	16Cr-12Ni-2Mo	8	(1)(20)(29)	70	25	0.90
	TP316L	...	S31603	16Cr-12Ni-2Mo	8	(1)(21)(29)	70	25	0.80
	TP316L	...	S31603	16Cr-12Ni-2Mo	8	(1)(9)(19)(29)	70	25	1.00
	TP316L	...	S31603	16Cr-12Ni-2Mo	8	(1)(9)(20)(29)	70	25	0.90
	TP316L	...	S31603	16Cr-12Ni-2Mo	8	(1)(9)(21)(29)	70	25	0.80
Ferritic/Austenitic									
A928	S31803	1 & 3	S32205	22Cr-5.5Ni-3Mo-N	10H	(1)(23)(24)	95	65	1.00
	S31803	2	S31803	22Cr-5.5Ni-3Mo-N	10H	(1)(23)(24)	90	65	0.90
	2205	1 & 3	S32205	22Cr-5.5Ni-3Mo-N	10H	(1)(23)(24)	95	65	1.00
	2205	2	S32205	22Cr-5.5Ni-3Mo-N	10H	(1)(23)(24)	95	65	0.90
Plate, Sheet, and Strip									
Austenitic									
A240	N08904	44Fe-25Ni-21Cr-Mo	45	(1)	71	31	1.00
	201LN	...	S20153	16Cr-4Ni-6Mn	8	(1)	95	45	1.00
	201LN	...	S20153	16Cr-4Ni-6Mn	8	(1)(9)	95	45	1.00
A240	304	...	S30400	18Cr-8Ni	8	(10)(11)	75	30	1.00
	304	...	S30400	18Cr-8Ni	8	(9)(10)(11)	75	30	1.00
	304L	...	S30403	18Cr-8Ni	8	(1)	70	25	1.00
	304L	...	S30403	18Cr-8Ni	8	(1)(9)	70	25	1.00
	304N	...	S30451	18Cr-8Ni-N	8	(1)(10)	80	35	1.00
	304N	...	S30451	18Cr-8Ni-N	8	(1)(9)(10)	80	35	1.00
A240	S30815	21Cr-11Ni-N	8	(1)	87	45	1.00
	S30815	21Cr-11Ni-N	8	(1)(9)	87	45	1.00
A240	309H	...	S30909	23Cr-12Ni	8	(9)(11)(18)	75	30	1.00
	309H	...	S30909	23Cr-12Ni	8	(11)(18)	75	30	1.00
	309S	...	S30908	23Cr-12Ni	8	(1)(10)	75	30	1.00
	309S	...	S30908	23Cr-12Ni	8	(1)(9)(10)	75	30	1.00
A240	310H	...	S31009	25Cr-20Ni	8	(9)	75	30	1.00
	310H	...	S31009	25Cr-20Ni	8	...	75	30	1.00
	310S	...	S31008	25Cr-20Ni	8	(10)(11)(14)	75	30	1.00
	310S	...	S31008	25Cr-20Ni	8	(9)(10)(11)(14)	75	30	1.00
	310S	...	S31008	25Cr-20Ni	8	(10)(11)(15)	75	30	1.00
	310S	...	S31008	25Cr-20Ni	8	(9)(10)(11)(15)	75	30	1.00
A240	316	...	S31600	16Cr-12Ni-2Mo	8	(10)(11)	75	30	1.00
	316	...	S31600	16Cr-12Ni-2Mo	8	(9)(10)(11)	75	30	1.00
	316L	...	S31603	16Cr-12Ni-2Mo	8	(1)(29)	70	25	1.00
	316L	...	S31603	16Cr-12Ni-2Mo	8	(1)(9)(29)	70	25	1.00
	316N	...	S31651	16Cr-12Ni-2Mo-N	8	(10)	80	35	1.00
	316N	...	S31651	16Cr-12Ni-2Mo-N	8	(9)(10)	80	35	1.00

Table A-3 Stainless Steels (Cont'd)

(16)

Maximum Allowable Stress Values in Tension, ksi, for Metal Temperature, °F, Not Exceeding																		Type or Grade	Spec. No.
100	200	300	400	500	600	650	700	750	800	850	900	950	1,000	1,050	1,100	1,150	1,200		
																		Welded Pipe – Filler Metal Added (Cont'd)	
																		Austenitic (Cont'd)	
16.7	14.2	12.7	11.7	10.9	10.4	10.2	10.0	9.8	9.6	9.4	9.2	9.0	8.8	8.6	8.4	8.3	6.4	TP316L	A409
15.0	12.8	11.4	10.5	9.8	9.4	9.2	9.0	8.8	8.6	8.4	8.3	8.1	7.9	7.7	7.6	7.5	5.8	TP316L	
13.3	11.4	10.2	9.3	8.7	8.3	8.1	8.0	7.8	7.7	7.5	7.4	7.2	7.0	6.9	6.7	6.6	5.1	TP316L	
16.7	16.7	16.7	15.7	14.8	14.0	13.7	13.5	13.2	12.9	12.7	12.4	12.1	11.9	11.6	11.4	8.8	6.4	TP316L	
15.0	15.0	15.0	14.2	13.3	12.6	12.4	12.1	11.9	11.6	11.4	11.2	10.9	10.7	10.4	10.3	7.9	5.8	TP316L	
13.3	13.3	13.3	12.6	11.8	11.2	11.0	10.8	10.6	10.3	10.1	9.9	9.7	9.5	9.3	9.1	7.0	5.1	TP316L	
																		Ferritic/Austenitic	
25.7	25.7	24.8	23.9	23.3	23.1	S31803	A928
23.1	23.1	22.3	21.5	21.0	20.8	S31803	
27.1	27.1	26.2	25.2	24.6	24.3	2205	
24.4	24.4	23.6	22.7	22.1	21.9	2205	
																		Plate, Sheet, and Strip Austenitic	
20.3	16.7	15.1	13.8	12.7	11.9	11.6	11.4	A240
27.1	23.7	21.2	20.1	19.7	19.2	18.6	18.0	17.4	16.7	201LN	
27.1	23.7	21.2	20.1	20.0	19.6	19.6	19.4	19.2	18.8	201LN	
20.0	16.7	15.0	13.8	12.9	12.3	12.0	11.7	11.5	11.2	11.0	10.8	10.6	10.4	10.1	9.8	7.7	6.1	304	A240
20.0	20.0	18.9	18.3	17.5	16.6	16.2	15.8	15.5	15.2	14.9	14.6	14.3	14.0	12.4	9.8	7.7	6.1	304	
16.7	14.3	12.8	11.7	10.9	10.4	10.2	10.0	9.8	9.7	304L	
16.7	16.7	16.7	15.8	14.7	14.0	13.7	13.5	13.3	13.0	304L	
22.9	19.1	16.7	15.1	14.0	13.3	13.0	12.8	12.5	12.3	12.1	11.8	11.6	11.3	11.0	9.8	7.7	6.1	304N	
22.9	22.9	21.7	20.3	18.9	17.9	17.5	17.2	16.9	16.6	16.3	16.0	15.6	15.2	12.4	9.8	7.7	6.1	304N	
24.9	24.7	22.0	19.9	18.5	17.7	17.4	17.2	17.0	16.8	16.6	16.4	16.2	14.9	11.6	9.0	6.9	5.2	...	A240
24.9	24.7	23.3	22.4	21.8	21.4	21.2	21.0	20.8	20.6	20.3	20.0	19.1	14.9	11.6	9.0	6.9	5.2	...	
20.0	20.0	20.0	20.0	19.4	18.8	18.5	18.2	18.0	17.7	17.5	17.2	16.9	13.8	10.3	7.6	5.5	4.0	309H	A240
20.0	17.5	16.1	15.1	14.4	13.9	13.7	13.5	13.3	13.1	12.9	12.7	12.5	12.3	10.3	7.6	5.5	4.0	309H	
20.0	17.5	16.1	15.1	14.4	13.9	13.7	13.5	13.3	13.1	12.9	12.7	12.5	9.9	7.1	5.0	3.6	2.5	309S	
20.0	20.0	20.0	20.0	19.4	18.8	18.5	18.2	18.0	17.7	17.5	17.2	15.9	9.9	7.1	5.0	3.6	2.5	309S	
20.0	20.0	20.0	19.9	19.3	18.5	18.2	17.9	17.7	17.4	17.2	16.9	16.7	13.8	10.3	7.6	5.5	4.0	310H	A240
20.0	17.6	16.1	15.1	14.3	13.7	13.5	13.3	13.1	12.9	12.7	12.5	12.3	12.1	10.3	7.6	5.5	4.0	310H	
20.0	17.6	16.1	15.1	14.3	13.7	13.5	13.3	13.1	12.9	12.7	12.5	12.3	9.9	7.1	5.0	3.6	2.5	310S	
20.0	20.0	20.0	19.9	19.3	18.5	18.2	17.9	17.7	17.4	17.2	16.9	15.9	9.9	7.1	5.0	3.6	2.5	310S	
20.0	17.6	16.1	15.1	14.3	13.7	13.5	13.3	13.1	12.9	12.7	12.5	12.3	9.9	7.1	5.0	3.6	2.5	310S	
20.0	20.0	20.0	19.9	19.3	18.5	18.2	17.9	17.7	17.4	17.2	16.9	15.9	9.9	7.1	5.0	3.6	2.5	310S	
20.0	17.3	15.6	14.3	13.3	12.6	12.3	12.1	11.9	11.8	11.6	11.5	11.4	11.3	11.2	11.1	9.8	7.4	316	A240
20.0	20.0	20.0	19.3	18.0	17.0	16.6	16.3	16.1	15.9	15.7	15.6	15.4	15.3	15.1	12.4	9.8	7.4	316	
16.7	14.2	12.7	11.7	10.9	10.4	10.2	10.0	9.8	9.6	9.4	9.2	9.0	8.8	8.6	8.4	8.3	6.4	316L	
16.7	16.7	16.7	15.7	14.8	14.0	13.7	13.5	13.2	12.9	12.7	12.4	12.1	11.9	11.6	11.4	8.8	6.4	316L	
22.9	20.7	19.0	17.6	16.5	15.6	15.2	14.9	14.5	14.2	13.9	13.7	13.4	13.2	12.9	12.3	9.8	7.4	316N	
22.9	22.9	22.0	21.5	21.2	21.0	20.5	20.0	19.6	19.2	18.8	18.5	18.1	17.8	15.8	12.3	9.8	7.4	316N	

(16)

Table A-3 Stainless Steels (Cont'd)

Spec. No.	Type or Grade	Class	UNS Alloy No.	Nominal Composition	P-No.	Notes	Specified Minimum Tensile, ksi	Specified Minimum Yield, ksi	E or F
Plate, Sheet, and Strip (Cont'd)									
Austenitic (Cont'd)									
A240	317	...	S31700	18Cr-13Ni-3Mo	8	(1)(10)(11)	75	30	1.00
	317	...	S31700	18Cr-13Ni-3Mo	8	(1)(9)(10)(11)	75	30	1.00
	317L	...	S31703	18Cr-13Ni-3Mo	8	(1)	75	30	1.00
	317L	...	S31703	18Cr-13Ni-3Mo	8	(1)(9)	75	30	1.00
	321	...	S32100	18Cr-10Ni-Ti	8	(10)(11)	75	30	1.00
	321	...	S32100	18Cr-10Ni-Ti	8	(9)(10)(11)	75	30	1.00
A240	347	...	S34700	18Cr-10Ni-Cb	8	(10)(11)	75	30	1.00
	347	...	S34700	18Cr-10Ni-Cb	8	(9)(10)(11)	75	30	1.00
	348	...	S34800	18Cr-10Ni-Cb	8	(1)(10)(11)	75	30	1.00
	348	...	S34800	18Cr-10Ni-Cb	8	(1)(9)(10)(11)	75	30	1.00
A240	XM-15	...	S38100	18Cr-8Ni-2Si	8	(1)	75	30	1.00
	XM-15	...	S38100	18Cr-8Ni-2Si	8	(1)(9)	75	30	1.00
	317LMN	...	S31726	19Cr-15.5Ni-4Mo	8	(1)	80	35	1.00
	317LMN	...	S31726	19Cr-15.5Ni-4Mo	8	(1)(9)	80	35	1.00
A240	S31254	20Cr-18Ni-6Mo	8	(1)	95	45	1.00
	S31254	20Cr-18Ni-6Mo	8	(1)(9)	95	45	1.00
	S31254	20Cr-18Ni-6Mo	8	(1)	100	45	1.00
	S31254	20Cr-18Ni-6Mo	8	(1)(9)	100	45	1.00
	S32550	25.5Cr-5.5Ni-3.5Mo-2Cu	10H	(1)(25)(26)	110	80	1.00
Ferritic/Martensitic									
A240	405	...	S40500	12Cr-1Al	7	(3)	60	25	1.00
	410	...	S41000	13Cr	6	(1)	65	30	1.00
	410S	...	S41008	13Cr	7	(1)	60	30	1.00
	429	...	S42900	15Cr	6	(1)(3)	65	30	1.00
A240	430	...	S43000	17Cr	7	(1)(3)	65	30	1.00
	XM-27	...	S44627	26Cr-1Mo	10I	(1)(3)	65	40	1.00
	XM-33	...	S44626	27Cr-1Mo-Ti	10I	(2)	68	45	1.00
Ferritic/Austenitic									
A240	S31803	...	S31803	22Cr-5.5Ni-3Mo-N	10H	(1)(23)(24)	90	65	1.00
	S32101	...	S32101	21Cr-5Mn-1.5Ni-Cu-N	10H	(1)(23)(24)	94	65	1.00
	2205	...	S32205	22Cr-5.5Ni-3Mo-N	10H	(1)(23)(24)	95	65	1.00
	S32101	...	S32101	21Cr-5Mn-1.5Ni-Cu-N	10H	(1)(23)(24)	101	77	1.00
	S32750	...	S32750	25Cr-7Ni-4Mo-N	10H	(1)(22)(23)	116	80	1.00
Forgings									
Austenitic									
A182	F904L	...	N08904	44Fe-25Ni-21Cr-Mo	45	(1)	71	31	1.00
	F44	...	S31254	20Cr-18Ni-6Mo	8	(1)	94	44	1.00
	F44	...	S31254	20Cr-18Ni-6Mo	8	(1)(9)	94	44	1.00
A182	F304	...	S30400	18Cr-8Ni	8	(10)(12)	70	30	1.00
	F304	...	S30400	18Cr-8Ni	8	(9)(10)(12)	70	30	1.00
	F304	...	S30400	18Cr-8Ni	8	(10)	75	30	1.00
	F304	...	S30400	18Cr-8Ni	8	(9)(10)	75	30	1.00
A182	F304H	...	S30409	18Cr-8Ni	8	(12)	70	30	1.00
	F304H	...	S30409	18Cr-8Ni	8	(9)(12)	70	30	1.00
	F304H	...	S30409	18Cr-8Ni	8	...	75	30	1.00
	F304H	...	S30409	18Cr-8Ni	8	(9)	75	30	1.00

Table A-3 Stainless Steels (Cont'd)

(16)

Maximum Allowable Stress Values in Tension, ksi, for Metal Temperature, °F, Not Exceeding																			Type or Grade	Spec. No.
100	200	300	400	500	600	650	700	750	800	850	900	950	1,000	1,050	1,100	1,150	1,200			
																			Plate, Sheet, and Strip (Cont'd)	
																			Austenitic (Cont'd)	
20.0	17.3	15.6	14.3	13.3	12.6	12.3	12.1	11.9	11.8	11.6	11.5	11.4	11.3	11.2	11.1	9.8	7.4	317	A240	
20.0	20.0	20.0	19.3	18.0	17.0	16.6	16.3	16.1	15.9	15.7	15.6	15.4	15.3	15.1	12.4	9.8	7.4	317		
20.0	17.0	15.2	14.0	13.1	12.5	12.2	12.0	11.7	11.5	11.3	317L		
20.0	20.0	19.6	18.9	17.7	16.9	16.5	16.2	15.8	15.5	15.2	317L		
20.0	18.0	16.5	15.3	14.3	13.5	13.2	13.0	12.7	12.6	12.4	12.3	12.1	12.0	9.6	6.9	5.0	3.6	321		
20.0	20.0	19.1	18.7	18.7	18.3	17.9	17.5	17.2	16.9	16.7	16.5	16.4	16.2	9.6	6.9	5.0	3.6	321		
20.0	18.4	17.1	16.0	15.0	14.3	14.0	13.8	13.7	13.6	13.5	13.4	13.4	13.4	12.1	9.1	6.1	4.4	347	A240	
20.0	20.0	18.8	17.8	17.2	16.9	16.8	16.8	16.8	16.8	16.8	16.7	16.6	16.0	12.1	9.1	6.1	4.4	347		
20.0	18.4	17.1	16.0	15.0	14.3	14.0	13.8	13.7	13.6	13.5	13.4	13.4	13.4	12.1	9.1	6.1	4.4	348		
20.0	20.0	18.8	17.8	17.2	16.9	16.8	16.8	16.8	16.8	16.8	16.7	16.6	16.0	12.1	9.1	6.1	4.4	348		
20.0	16.7	15.0	13.8	12.9	12.3	12.0	11.7	11.5	11.2	11.0	10.8	10.6	10.4	XM-15	A240	
20.0	20.0	18.9	18.3	17.5	16.6	16.2	15.8	15.5	15.2	14.9	14.6	14.3	14.0	XM-15		
22.9	20.0	17.9	16.3	15.3	14.6	317LMN		
22.9	21.8	20.9	20.5	20.3	19.7	317LMN		
27.1	24.5	21.9	20.2	19.1	18.3	18.0	17.8	17.7	A240	
27.1	27.1	25.8	24.6	23.7	23.2	23.1	23.0	22.9		
28.6	24.5	21.9	20.2	19.1	18.3	18.0	17.8	17.7		
28.6	28.6	27.2	25.9	25.0	24.4	24.3	24.1	23.9		
31.4	31.3	29.5	28.6	28.2		
																			Ferritic/Martensitic	
16.7	15.3	14.8	14.5	14.3	14.0	13.8	13.5	405	A240	
18.6	18.4	17.8	17.4	17.2	16.8	16.6	16.2	15.7	15.1	14.4	12.3	8.8	6.4	4.4	2.9	1.8	1.0	410		
17.1	17.1	16.8	16.5	16.3	15.9	15.6	15.2	14.7	14.1	13.4	12.3	8.8	6.4	4.4	2.9	1.8	1.0	410S		
18.6	18.4	17.8	17.4	17.2	16.8	16.6	16.2	15.7	15.1	14.4	12.0	9.2	6.5	4.5	3.2	2.4	1.8	429		
18.6	18.4	17.8	17.4	17.2	16.8	16.6	16.2	15.7	15.1	14.4	12.0	9.2	6.5	4.5	3.2	2.4	1.8	430	A240	
18.6	18.6	18.3	18.1	18.1	18.1	18.1	XM-27		
19.4	19.4	19.3	19.0	18.8	18.4	18.1	XM-33		
																			Ferritic/Austenitic	
25.7	25.7	24.8	23.9	23.3	23.1	S31803	A240	
26.9	26.9	25.6	24.7	24.7	24.7	S32101		
27.1	27.1	26.2	25.2	24.6	24.3	2205		
28.9	28.9	27.5	26.5	26.5	26.5	S32101		
33.1	33.0	31.2	30.1	29.6	29.4	S32750		
																			Forgings	
																			Austenitic	
20.3	16.7	15.1	13.8	12.7	11.9	11.6	11.4	F904L	A182	
26.9	23.9	21.4	19.8	18.6	17.9	17.6	17.4	17.3	F44		
26.9	26.9	25.5	24.3	23.5	23.0	22.8	22.7	22.6	F44		
20.0	16.7	15.0	13.8	12.9	12.3	12.0	11.7	11.5	11.2	11.0	10.8	10.6	10.4	10.1	9.8	7.7	6.1	F304	A182	
20.0	20.0	18.9	18.3	17.5	16.6	16.2	15.8	15.5	15.2	14.9	14.6	14.3	14.0	12.4	9.8	7.7	6.1	F304		
20.0	16.7	15.0	13.8	12.9	12.3	12.0	11.7	11.5	11.2	11.0	10.8	10.6	10.4	10.1	9.8	7.7	6.1	F304		
20.0	20.0	18.9	18.3	17.5	16.6	16.2	15.8	15.5	15.2	14.9	14.6	14.3	14.0	12.4	9.8	7.7	6.1	F304		
20.0	16.7	15.0	13.8	12.9	12.3	12.0	11.7	11.5	11.2	11.0	10.8	10.6	10.4	10.1	9.8	7.7	6.1	F304H	A182	
20.0	18.9	17.7	17.1	16.9	16.6	16.2	15.8	15.5	15.2	14.9	14.6	14.3	14.0	12.4	9.8	7.7	6.1	F304H		
20.0	16.7	15.0	13.8	12.9	12.3	12.0	11.7	11.5	11.2	11.0	10.8	10.6	10.4	10.1	9.8	7.7	6.1	F304H		
20.0	20.0	18.9	18.3	17.5	16.6	16.2	15.8	15.5	15.2	14.9	14.6	14.3	14.0	12.4	9.8	7.7	6.1	F304H		

Table A-3 Stainless Steels (Cont'd)

Spec. No.	Type or Grade	Class	UNS Alloy No.	Nominal Composition	P-No.	Notes	Specified Minimum Tensile, ksi	Specified Minimum Yield, ksi	E or F
Forgings (Cont'd)									
Austenitic (Cont'd)									
A182	F304L	...	S30403	18Cr-8Ni	8	(1)	65	25	1.00
	F304L	...	S30403	18Cr-8Ni	8	(1)(9)	65	25	1.00
	F304N	...	S30451	18Cr-8Ni-N	8	(10)	80	35	1.00
	F304N	...	S30451	18Cr-8Ni-N	8	(9)(10)	80	35	1.00
A182	S30815	21Cr-11Ni-N	8	(1)	87	45	1.00
	S30815	21Cr-11Ni-N	8	(1)(9)	87	45	1.00
A182	F310	...	S31000	25Cr-20Ni	8	(1)(10)(14)	75	30	1.00
	F310	...	S31000	25Cr-20Ni	8	(1)(9)(10)(14)	75	30	1.00
	F310	...	S31000	25Cr-20Ni	8	(1)(10)(15)	75	30	1.00
	F310	...	S31000	25Cr-20Ni	8	(1)(9)(10)(15)	75	30	1.00
A182	F316	...	S31600	16Cr-12Ni-2Mo	8	(10)(12)	70	30	1.00
	F316	...	S31600	16Cr-12Ni-2Mo	8	(9)(10)(12)	70	30	1.00
	F316	...	S31600	16Cr-12Ni-2Mo	8	(10)	75	30	1.00
	F316	...	S31600	16Cr-12Ni-2Mo	8	(9)(10)	75	30	1.00
A182	F316H	...	S31609	16Cr-12Ni-2Mo	8	(12)	70	30	1.00
	F316H	...	S31609	16Cr-12Ni-2Mo	8	(9)(12)	70	30	1.00
	F316H	...	S31609	16Cr-12Ni-2Mo	8	...	75	30	1.00
	F316H	...	S31609	16Cr-12Ni-2Mo	8	(9)	75	30	1.00
A182	F316L	...	S31603	16Cr-12Ni-2Mo	8	(1)(27)(29)	70	25	1.00
	F316L	...	S31603	16Cr-12Ni-2Mo	8	(1)(9)(27)(29)	70	25	1.00
	F316N	...	S31651	16Cr-12Ni-2Mo-N	8	(10)	80	35	1.00
	F316N	...	S31651	16Cr-12Ni-2Mo-N	8	(9)(10)	80	35	1.00
A182	F321	...	S32100	18Cr-10Ni-Ti	8	(12)	70	30	1.00
	F321	...	S32100	18Cr-10Ni-Ti	8	(9)(12)	70	30	1.00
	F321	...	S32100	18Cr-10Ni-Ti	8	(10)	75	30	1.00
	F321	...	S32100	18Cr-10Ni-Ti	8	(9)(10)	75	30	1.00
A182	F321H	...	S32109	18Cr-10Ni-Ti	8	(12)	70	30	1.00
	F321H	...	S32109	18Cr-10Ni-Ti	8	(9)(12)	70	30	1.00
	F321H	...	S32109	18Cr-10Ni-Ti	8	...	75	30	1.00
	F321H	...	S32109	18Cr-10Ni-Ti	8	(9)	75	30	1.00
A182	F347	...	S34700	18Cr-10Ni-Cb	8	(12)	70	30	1.00
	F347	...	S34700	18Cr-10Ni-Cb	8	(9)(12)	70	30	1.00
	F347	...	S34700	18Cr-10Ni-Cb	8	(10)	75	30	1.00
	F347	...	S34700	18Cr-10Ni-Cb	8	(9)(10)	75	30	1.00
A182	F347H	...	S34709	18Cr-10Ni-Cb	8	(12)	70	30	1.00
	F347H	...	S34709	18Cr-10Ni-Cb	8	(9)(12)	70	30	1.00
	F347H	...	S34709	18Cr-10Ni-Cb	8	...	75	30	1.00
	F347H	...	S34709	18Cr-10Ni-Cb	8	(9)	75	30	1.00
A182	F348	...	S34800	18Cr-10Ni-Cb	8	(12)	70	30	1.00
	F348	...	S34800	18Cr-10Ni-Cb	8	(9)(12)	70	30	1.00
	F348	...	S34800	18Cr-10Ni-Cb	8	(10)	75	30	1.00
	F348	...	S34800	18Cr-10Ni-Cb	8	(9)(10)	75	30	1.00

Table A-3 Stainless Steels (Cont'd)

Maximum Allowable Stress Values in Tension, ksi, for Metal Temperature, °F, Not Exceeding																			Type or Grade	Spec. No.
100	200	300	400	500	600	650	700	750	800	850	900	950	1,000	1,050	1,100	1,150	1,200			
																			Forgings (Cont'd)	
																			Austenitic (Cont'd)	
16.7	14.3	12.8	11.7	10.9	10.4	10.2	10.0	9.8	9.7	F304L	A182
16.7	16.7	16.2	15.6	14.7	14.0	13.7	13.5	13.3	13.0	F304L	
22.9	19.1	16.7	15.1	14.0	13.3	13.0	12.8	12.5	12.3	12.1	11.8	11.6	11.3	11.0	9.8	7.7	6.1	F304N		
22.9	22.9	21.7	20.3	18.9	17.9	17.5	17.2	16.9	16.6	16.3	16.0	15.6	15.2	12.4	9.8	7.7	6.1	F304N		
24.9	24.7	22.0	19.9	18.5	17.7	17.4	17.2	17.0	16.8	16.6	16.4	16.2	14.9	11.6	9.0	6.9	5.2	...	A182	
24.9	24.7	23.3	22.4	21.8	21.4	21.2	21.0	20.8	20.6	20.3	20.0	19.1	14.9	11.6	9.0	6.9	5.2	...		
20.0	17.6	16.1	15.1	14.3	13.7	13.5	13.3	13.1	12.9	12.7	12.5	12.3	9.9	7.1	5.0	3.6	2.5	F310	A182	
20.0	20.0	20.0	19.9	19.3	18.5	18.2	17.9	17.7	17.4	17.2	16.9	15.9	9.9	7.1	5.0	3.6	2.5	F310		
20.0	17.6	16.1	15.1	14.3	13.7	13.5	13.3	13.1	12.9	12.7	12.5	12.3	9.9	7.1	5.0	3.6	2.5	F310		
20.0	20.0	20.0	19.9	19.3	18.5	18.2	17.9	17.7	17.4	17.2	16.9	15.9	9.9	7.1	5.0	3.6	2.5	F310		
20.0	17.3	15.6	14.3	13.3	12.6	12.3	12.1	11.9	11.8	11.6	11.5	11.4	11.3	11.2	11.1	9.8	7.4	F316	A182	
20.0	20.0	19.4	19.2	18.0	17.0	16.6	16.3	16.1	15.9	15.7	15.6	15.4	15.3	15.1	12.4	9.8	7.4	F316		
20.0	17.3	15.6	14.3	13.3	12.6	12.3	12.1	11.9	11.8	11.6	11.5	11.4	11.3	11.2	11.1	9.8	7.4	F316		
20.0	20.0	20.0	19.3	18.0	17.0	16.6	16.3	16.1	15.9	15.7	15.6	15.4	15.3	15.1	12.4	9.8	7.4	F316		
20.0	17.3	15.6	14.3	13.3	12.6	12.3	12.1	11.9	11.8	11.6	11.5	11.4	11.3	11.2	11.1	9.8	7.4	F316H	A182	
20.0	20.0	19.4	19.2	18.0	17.0	16.6	16.3	16.1	15.9	15.7	15.6	15.4	15.3	15.1	12.4	9.8	7.4	F316H		
20.0	17.3	15.6	14.3	13.3	12.6	12.3	12.1	11.9	11.8	11.6	11.5	11.4	11.3	11.2	11.1	9.8	7.4	F316H		
20.0	20.0	20.0	19.3	18.0	17.0	16.6	16.3	16.1	15.9	15.7	15.6	15.4	15.3	15.1	12.4	9.8	7.4	F316H		
16.7	14.1	12.7	11.7	10.9	10.4	10.2	10.0	9.8	9.6	9.4	9.2	9.0	8.8	8.6	8.4	8.3	6.4	F316L	A182	
16.7	16.7	16.7	15.6	14.8	14.0	13.8	13.5	13.2	13.0	12.7	12.4	12.1	11.9	11.6	11.4	8.8	6.4	F316L		
22.9	20.7	19.0	17.6	16.5	15.6	15.2	14.9	14.5	14.2	13.9	13.7	13.4	13.2	12.9	12.3	9.8	7.4	F316N		
22.9	22.9	22.0	21.5	21.2	21.0	20.5	20.0	19.6	19.2	18.8	18.5	18.1	17.8	15.8	12.3	9.8	7.4	F316N		
20.0	18.0	16.5	15.3	14.3	13.5	13.2	13.0	12.7	12.6	12.4	12.3	12.1	12.0	9.6	6.9	5.0	3.6	F321	A182	
20.0	19.0	17.8	17.5	17.5	17.5	17.5	17.5	17.2	16.9	16.7	16.5	16.4	16.2	9.6	6.9	5.0	3.6	F321		
20.0	18.0	16.5	15.3	14.3	13.5	13.2	13.0	12.7	12.6	12.4	12.3	12.1	12.0	9.6	6.9	5.0	3.6	F321		
20.0	20.0	19.1	18.7	18.7	18.3	17.9	17.5	17.2	16.9	16.7	16.5	16.4	16.2	9.6	6.9	5.0	3.6	F321		
20.0	18.0	16.5	15.3	14.3	13.5	13.2	13.0	12.7	12.6	12.4	12.3	12.1	12.0	11.9	9.1	6.9	5.4	F321H	A182	
20.0	19.0	17.8	17.5	17.5	17.5	17.5	17.5	17.2	16.9	16.7	16.5	16.4	16.2	12.3	9.1	6.9	5.4	F321H		
20.0	18.0	16.5	15.3	14.3	13.5	13.2	13.0	12.7	12.6	12.4	12.3	12.1	12.0	11.9	9.1	6.9	5.4	F321H		
20.0	20.0	19.1	18.7	18.7	18.3	17.9	17.5	17.2	16.9	16.7	16.5	16.4	16.2	12.3	9.1	6.9	5.4	F321H		
20.0	18.4	17.1	16.0	15.0	14.3	14.0	13.8	13.7	13.6	13.5	13.4	13.4	13.4	12.1	9.1	6.1	4.4	F347	A182	
20.0	19.1	17.6	16.6	16.0	15.8	15.7	15.7	15.7	15.7	15.7	15.6	15.5	15.3	12.1	9.1	6.1	4.4	F347		
20.0	18.4	17.1	16.0	15.0	14.3	14.0	13.8	13.7	13.6	13.5	13.4	13.4	13.4	12.1	9.1	6.1	4.4	F347		
20.0	20.0	18.8	17.8	17.2	16.9	16.8	16.8	16.8	16.8	16.8	16.7	16.6	16.0	12.1	9.1	6.1	4.4	F347		
20.0	18.4	17.1	16.0	15.0	14.3	14.0	13.8	13.7	13.6	13.5	13.4	13.4	13.4	13.4	13.3	10.5	7.9	F347H	A182	
20.0	19.1	17.6	16.6	16.0	15.7	15.7	15.7	15.7	15.7	15.7	15.6	15.5	15.3	15.1	14.1	10.5	7.9	F347H		
20.0	18.4	17.1	16.0	15.0	14.3	14.0	13.8	13.7	13.6	13.5	13.4	13.4	13.4	13.4	13.3	10.5	7.9	F347H		
20.0	20.0	18.8	17.8	17.1	16.9	16.8	16.8	16.8	16.8	16.8	16.7	16.6	16.4	16.2	14.1	10.5	7.9	F347H		
20.0	18.4	17.1	16.0	15.0	14.3	14.0	13.8	13.7	13.6	13.5	13.4	13.4	13.4	12.1	9.1	6.1	4.4	F348	A182	
20.0	19.1	17.6	16.6	16.0	15.8	15.7	15.7	15.7	15.7	15.7	15.6	15.5	15.3	12.1	9.1	6.1	4.4	F348		
20.0	18.4	17.1	16.0	15.0	14.3	14.0	13.8	13.7	13.6	13.5	13.4	13.4	13.4	12.1	9.1	6.1	4.4	F348		
20.0	20.0	18.8	17.8	17.2	16.9	16.8	16.8	16.8	16.8	16.8	16.7	16.6	16.0	12.1	9.1	6.1	4.4	F348		

(16)

Table A-3 Stainless Steels (Cont'd)

Spec. No.	Type or Grade	Class	UNS Alloy No.	Nominal Composition	P-No.	Notes	Specified Minimum Tensile, ksi	Specified Minimum Yield, ksi	E or F
Forgings (Cont'd)									
Austenitic (Cont'd)									
A182	F348H	...	S34809	18Cr-10Ni-Cb	8	(12)	70	30	1.00
	F348H	...	S34809	18Cr-10Ni-Cb	8	(9)(12)	70	30	1.00
	F348H	...	S34809	18Cr-10Ni-Cb	8	...	75	30	1.00
	F348H	...	S34809	18Cr-10Ni-Cb	8	(9)	75	30	1.00
A965	F304	...	S30400	18Cr-8Ni	8	(10)	70	30	1.00
	F304	...	S30400	18Cr-8Ni	8	(9)(10)	70	30	1.00
	F304H	...	S30409	18Cr-8Ni	8	...	70	30	1.00
	F304H	...	S30409	18Cr-8Ni	8	(9)	70	30	1.00
A965	F316	...	S31600	16Cr-12Ni-2Mo	8	(10)	70	30	1.00
	F316	...	S31600	16Cr-12Ni-2Mo	8	(9)(10)	70	30	1.00
	F316H	...	S31609	16Cr-12Ni-2Mo	8	...	70	30	1.00
	F316H	...	S31609	16Cr-12Ni-2Mo	8	(9)	70	30	1.00
A965	F321	...	S32100	18Cr-10Ni-Ti	8	(10)	70	30	1.00
	F321	...	S32100	18Cr-10Ni-Ti	8	(9)(10)	70	30	1.00
	F321H	...	S32109	18Cr-10Ni-Ti	8	...	70	30	1.00
	F321H	...	S32109	18Cr-10Ni-Ti	8	(9)	70	30	1.00
A965	F347	...	S34700	18Cr-10Ni-Cb	8	(10)	70	30	1.00
	F347	...	S34700	18Cr-10Ni-Cb	8	(9)(10)	70	30	1.00
	F347H	...	S34709	18Cr-10Ni-Cb	8	...	70	30	1.00
	F347H	...	S34709	18Cr-10Ni-Cb	8	(9)	70	30	1.00
Ferritic/Martensitic									
A182	FXM-27Cb	...	S44627	27Cr-1Mo	10I	(2)	60	35	1.00
A336	FXM-27Cb	...	S44627	27Cr-1Mo	10I	(2)	60	35	1.00
Ferritic/Austenitic									
A182	F51	...	S31803	22Cr-5.5Ni-3Mo-N	10H	(1)(23)(24)	90	65	1.00
	F60	...	S32205	22Cr-5.5Ni-3Mo-N	10H	(1)(23)(24)	95	70	1.00
	F53	...	S32750	25Cr-7Ni-4Mo-N	10H	(1)(22)(23)	116	80	1.00
Fittings (Seamless and Welded)									
Austenitic									
A403	WP304	...	S30400	18Cr-8Ni	8	(4)(7)(10)(11)	75	30	1.00
	WP304	...	S30400	18Cr-8Ni	8	(4)(7)(9)(10)(11)	75	30	1.00
	WP304H	...	S30409	18Cr-8Ni	8	(4)(7)(11)	75	30	1.00
	WP304H	...	S30409	18Cr-8Ni	8	(4)(7)(9)(11)	75	30	1.00
A403	WP304L	...	S30403	18Cr-8Ni	8	(1)(7)(11)	70	25	1.00
	WP304L	...	S30403	18Cr-8Ni	8	(1)(7)(9)(11)	70	25	1.00
	WP304N	...	S30451	18Cr-8Ni-N	8	(1)(4)(7)(10)	80	35	1.00
	WP304N	...	S30451	18Cr-8Ni-N	8	(1)(4)(7)(9)(10)	80	35	1.00
A403	WP309	...	S30900	23Cr-12Ni	8	(1)(7)(10)(11)	75	30	1.00
	WP309	...	S30900	23Cr-12Ni	8	(1)(7)(9)(10)(11)	75	30	1.00
	WP310	...	S31000	23Cr-20Ni	8	(1)(7)(10)(11)(14)	75	30	1.00
	WP310	...	S31000	23Cr-20Ni	8	(1)(7)(9)(10)(11)(14)	75	30	1.00
	WP310	...	S31000	23Cr-20Ni	8	(1)(7)(10)(11)(15)	75	30	1.00
	WP310	...	S31000	23Cr-20Ni	8	(1)(7)(9)(10)(11)(15)	75	30	1.00

Table A-3 Stainless Steels (Cont'd)

(16)

Maximum Allowable Stress Values in Tension, ksi, for Metal Temperature, °F, Not Exceeding																			Type or Grade	Spec. No.
100	200	300	400	500	600	650	700	750	800	850	900	950	1,000	1,050	1,100	1,150	1,200			
																			Forgings (Cont'd)	
																			Austenitic (Cont'd)	
20.0	18.4	17.1	16.0	15.0	14.3	14.0	13.8	13.7	13.6	13.5	13.4	13.4	13.4	13.4	13.3	10.5	7.9	F348H	A182	
20.0	19.1	17.6	16.6	16.0	15.7	15.7	15.7	15.7	15.7	15.7	15.6	15.5	15.3	15.1	14.1	10.5	7.9	F348H		
20.0	18.4	17.1	16.0	15.0	14.3	14.0	13.8	13.7	13.6	13.5	13.4	13.4	13.4	13.4	13.3	10.5	7.9	F348H		
20.0	20.0	18.8	17.8	17.1	16.9	16.8	16.8	16.8	16.8	16.8	16.7	16.6	16.4	16.2	14.1	10.5	7.9	F348H		
20.0	16.7	15.0	13.8	12.9	12.3	12.0	11.7	11.5	11.2	11.0	10.8	10.6	10.4	10.1	9.8	7.7	6.1	F304	A965	
20.0	20.0	18.9	18.3	17.5	16.6	16.2	15.8	15.5	15.2	14.9	14.6	14.3	14.0	12.4	9.8	7.7	6.1	F304		
20.0	16.7	15.0	13.8	12.9	12.3	12.0	11.7	11.5	11.2	11.0	10.8	10.6	10.4	10.1	9.8	7.7	6.1	F304H		
20.0	18.9	17.7	17.1	16.9	16.6	16.2	15.8	15.5	15.2	14.9	14.6	14.3	14.0	12.4	9.8	7.7	6.1	F304H		
20.0	17.3	15.6	14.3	13.3	12.6	12.3	12.1	11.9	11.8	11.6	11.5	11.4	11.3	11.2	11.1	9.8	7.4	F316	A965	
20.0	20.0	19.4	19.2	18.0	17.0	16.6	16.3	16.1	15.9	15.7	15.6	15.4	15.3	15.1	12.4	9.8	7.4	F316		
20.0	17.3	15.6	14.3	13.3	12.6	12.3	12.1	11.9	11.8	11.6	11.5	11.4	11.3	11.2	11.1	9.8	7.4	F316H		
20.0	20.0	19.4	19.2	18.0	17.0	16.6	16.3	16.1	15.9	15.7	15.6	15.4	15.3	15.1	12.4	9.8	7.4	F316H		
20.0	18.0	16.5	15.3	14.3	13.5	13.2	13.0	12.7	12.6	12.4	12.3	12.1	12.0	9.6	6.9	5.0	3.6	F321	A965	
20.0	19.0	17.8	17.5	17.5	17.5	17.5	17.5	17.2	16.9	16.7	16.5	16.4	16.2	9.6	6.9	5.0	3.6	F321		
20.0	18.0	16.5	15.3	14.3	13.5	13.2	13.0	12.7	12.6	12.4	12.3	12.1	12.0	11.9	9.1	6.9	5.4	F321H		
20.0	19.0	17.8	17.5	17.5	17.5	17.5	17.5	17.2	16.9	16.7	16.5	16.4	16.2	12.3	9.1	6.9	5.4	F321H		
20.0	18.4	17.1	16.0	15.0	14.3	14.0	13.8	13.7	13.6	13.5	13.4	13.4	13.4	12.1	9.1	6.1	4.4	F347	A965	
20.0	19.1	17.6	16.6	16.0	15.8	15.7	15.7	15.7	15.7	15.7	15.6	15.5	15.3	12.1	9.1	6.1	4.4	F347		
20.0	18.4	17.1	16.0	15.0	14.3	14.0	13.8	13.7	13.6	13.5	13.4	13.4	13.4	13.4	13.3	10.5	7.9	F347H		
20.0	19.1	17.6	16.6	16.0	15.7	15.7	15.7	15.7	15.7	15.7	15.6	15.5	15.3	15.1	14.1	10.5	7.9	F347H		
																			Ferritic/Martensitic	
17.1	17.1	16.6	16.1	16.1	16.1	16.1	FXM-27Cb	A182	
17.1	17.1	16.6	16.1	16.1	16.1	16.1	FXM-27Cb	A336	
																			Ferritic/Austenitic	
25.7	25.7	24.8	23.9	23.3	23.1	F51	A182	
27.1	27.1	26.2	25.2	24.6	24.3	F60		
33.1	33.0	31.2	30.1	29.6	29.4	F53		
																			Fittings (Seamless and Welded)	
																			Austenitic	
20.0	16.7	15.0	13.8	12.9	12.3	12.0	11.7	11.5	11.2	11.0	10.8	10.6	10.4	10.1	9.8	7.7	6.1	WP304	A403	
20.0	20.0	18.9	18.3	17.5	16.6	16.2	15.8	15.5	15.2	14.9	14.6	14.3	14.0	12.4	9.8	7.7	6.1	WP304		
20.0	16.7	15.0	13.8	12.9	12.3	12.0	11.7	11.5	11.2	11.0	10.8	10.6	10.4	10.1	9.8	7.7	6.1	WP304H		
20.0	20.0	18.9	18.3	17.5	16.6	16.2	15.8	15.5	15.2	14.9	14.6	14.3	14.0	12.4	9.8	7.7	6.1	WP304H		
16.7	14.3	12.8	11.7	10.9	10.4	10.2	10.0	9.8	9.7	WP304L	A403	
16.7	16.7	16.7	15.8	14.7	14.0	13.7	13.5	13.3	13.0	WP304L		
22.9	19.1	16.7	15.1	14.0	13.3	13.0	12.8	12.5	12.3	12.1	11.8	11.6	11.3	11.0	9.8	7.7	6.1	WP304N		
22.9	22.9	21.7	20.3	18.9	17.9	17.5	17.2	16.9	16.6	16.3	16.0	15.6	15.2	12.4	9.8	7.7	6.1	WP304N		
20.0	17.5	16.1	15.1	14.4	13.9	13.7	13.5	13.3	13.1	12.9	12.7	12.5	9.9	7.1	5.0	3.6	2.5	WP309	A403	
20.0	20.0	20.0	20.0	19.4	18.8	18.5	18.2	18.0	17.7	17.5	17.2	15.9	9.9	7.1	5.0	3.6	2.5	WP309		
20.0	17.6	16.1	15.1	14.3	13.7	13.5	13.3	13.1	12.9	12.7	12.5	12.3	9.9	7.1	5.0	3.6	2.5	WP310		
20.0	20.0	20.0	19.9	19.3	18.5	18.2	17.9	17.7	17.4	17.2	16.9	15.9	9.9	7.1	5.0	3.6	2.5	WP310		
20.0	17.6	16.1	15.1	14.3	13.7	13.5	13.3	13.1	12.9	12.7	12.5	12.3	9.9	7.1	5.0	3.6	2.5	WP310		
20.0	20.0	20.0	19.9	19.3	18.5	18.2	17.9	17.7	17.4	17.2	16.9	15.9	9.9	7.1	5.0	3.6	2.5	WP310		

(16)

Table A-3 Stainless Steels (Cont'd)

Spec. No.	Type or Grade	Class	UNS Alloy No.	Nominal Composition	P-No.	Notes	Specified Minimum Tensile, ksi	Specified Minimum Yield, ksi	E or F
Fittings (Seamless and Welded) (Cont'd)									
Austenitic (Cont'd)									
A403	WPS31254	...	S31254	20Cr-18Ni-6Mo	8	(1)(7)	94	44	1.00
	WPS31254	...	S31254	20Cr-18Ni-6Mo	8	(1)(7)(9)	94	44	1.00
A403	WP316	...	S31600	16Cr-12Ni-2Mo	8	(4)(7)(10)(11)	75	30	1.00
	WP316	...	S31600	16Cr-12Ni-2Mo	8	(4)(7)(9)(10)(11)	75	30	1.00
	WP316H	...	S31609	16Cr-12Ni-2Mo	8	(4)(7)(11)	75	30	1.00
	WP316H	...	S31609	16Cr-12Ni-2Mo	8	(4)(7)(9)(11)	75	30	1.00
A403	WP316L	...	S31603	16Cr-12Ni-2Mo	8	(1)(7)(11)(29)	70	25	1.00
	WP316L	...	S31603	16Cr-12Ni-2Mo	8	(1)(7)(9)(11)(29)	70	25	1.00
	WP316N	...	S31651	16Cr-12Ni-2Mo-N	8	(1)(7)(10)	80	35	1.00
	WP316N	...	S31651	16Cr-12Ni-2Mo-N	8	(1)(7)(9)(10)	80	35	1.00
	WPS31726	...	S31726	19Cr-15.5Ni-4Mo	8	(1)	80	35	1.00
	WPS31726	...	S31726	19Cr-15.5Ni-4Mo	8	(1)(9)	80	35	1.00
A403	WP317	...	S31700	18Cr-13Ni-3Mo	8	(1)(7)(10)(11)	75	30	1.00
	WP317	...	S31700	18Cr-13Ni-3Mo	8	(1)(7)(9)(10)(11)	75	30	1.00
	WP321	...	S32100	18Cr-10Ni-Ti	8	(4)(7)(10)(11)	75	30	1.00
	WP321	...	S32100	18Cr-10Ni-Ti	8	(4)(7)(9)(10)(11)	75	30	1.00
	WP321H	...	S32109	18Cr-10Ni-Ti	8	(4)(7)(11)	75	30	1.00
	WP321H	...	S32109	18Cr-10Ni-Ti	8	(4)(7)(9)(11)	75	30	1.00
A403	WP347	...	S34700	18Cr-10Ni-Cb	8	(4)(7)(10)(11)	75	30	1.00
	WP347	...	S34700	18Cr-10Ni-Cb	8	(4)(7)(9)(10)(11)	75	30	1.00
	WP347H	...	S34709	18Cr-10Ni-Cb	8	(4)(7)(11)	75	30	1.00
	WP347H	...	S34709	18Cr-10Ni-Cb	8	(4)(7)(9)(11)	75	30	1.00
A403	WP348	...	S34800	18Cr-10Ni-Cb	8	(4)(7)(10)(11)	75	30	1.00
	WP348	...	S34800	18Cr-10Ni-Cb	8	(4)(7)(9)(10)(11)	75	30	1.00
	WP348H	...	S34809	18Cr-10Ni-Cb	8	(4)(7)(11)	75	30	1.00
	WP348H	...	S34809	18Cr-10Ni-Cb	8	(4)(7)(9)(11)	75	30	1.00
Ferritic/Austenitic									
A815	S31803	...	S31803	22Cr-5.5Ni-3Mo-N	10H	(1)(23)(24)	90	65	1.00
	S32101	...	S32101	21Cr-5Mn-1.5Ni-Cu-N	10H	(1)(23)(24)	94	65	1.00
	S32205	...	S32205	22Cr-5.5Ni-3Mo-N	10H	(1)(23)(24)	95	70	1.00
	S32101	...	S32101	21Cr-5Mn-1.5Ni-Cu-N	10H	(1)(23)(24)	101	77	1.00
Castings									
Austenitic									
A351	CF3	...	J92500	18Cr-8Ni	8	(1)(5)(17)	70	30	0.80
	CF3	...	J92500	18Cr-8Ni	8	(1)(5)(9)(17)	70	30	0.80
	CF3A	...	J92500	18Cr-8Ni	8	(1)(5)(17)	77.5	35	0.80
	CF3A	...	J92500	18Cr-8Ni	8	(1)(5)(9)(17)	77.5	35	0.80
	CF3M	...	J92800	18Cr-12Ni-2Mo	8	(1)(5)(13)(17)	70	30	0.80
	CF3M	...	J92800	18Cr-12Ni-2Mo	8	(1)(5)(9)(13)(17)	70	30	0.80
A351	CF8	...	J92600	18Cr-8Ni	8	(5)(10)(17)	70	30	0.80
	CF8	...	J92600	18Cr-8Ni	8	(5)(9)(10)(17)	70	30	0.80
	CF8C	...	J92710	18Cr-10Ni-Cb	8	(1)(5)(10)(17)	70	30	0.80
	CF8C	...	J92710	18Cr-10Ni-Cb	8	(1)(5)(9)(10)(17)	70	30	0.80
	CF8M	...	J92900	16Cr-12Ni-2Mo	8	(5)(13)(17)	70	30	0.80
	CF8M	...	J92900	16Cr-12Ni-2Mo	8	(5)(9)(13)(17)	70	30	0.80

Table A-3 Stainless Steels (Cont'd)

(16)

Maximum Allowable Stress Values in Tension, ksi, for Metal Temperature, °F, Not Exceeding																			Type or Grade	Spec. No.
100	200	300	400	500	600	650	700	750	800	850	900	950	1,000	1,050	1,100	1,150	1,200			
																			Fittings (Seamless and Welded) (Cont'd)	
																			Austenitic (Cont'd)	
26.9	23.9	21.4	19.8	18.6	17.9	17.6	17.4	17.3	WPS31254	A403
26.9	26.9	25.5	24.3	23.5	23.0	22.8	22.7	22.6	WPS31254	
20.0	17.3	15.6	14.3	13.3	12.6	12.3	12.1	11.9	11.8	11.6	11.5	11.4	11.3	11.2	11.1	9.8	7.4	WP316	A403	
20.0	20.0	20.0	19.3	18.0	17.0	16.6	16.3	16.1	15.9	15.7	15.6	15.4	15.3	15.1	12.4	9.8	7.4	WP316		
20.0	17.3	15.6	14.3	13.3	12.6	12.3	12.1	11.9	11.8	11.6	11.5	11.4	11.3	11.2	11.1	9.8	7.4	WP316H		
20.0	20.0	20.0	19.3	18.0	17.0	16.6	16.3	16.1	15.9	15.7	15.6	15.4	15.3	15.1	12.4	9.8	7.4	WP316H		
16.7	14.1	12.7	11.7	10.9	10.4	10.2	10.0	9.8	9.6	9.4	9.2	9.0	8.8	8.6	8.4	8.3	6.4	WP316L	A403	
16.7	16.7	16.0	15.6	14.8	14.0	13.8	13.5	13.2	13.0	12.7	12.4	12.1	11.9	11.6	11.4	8.8	6.4	WP316L		
22.9	20.7	19.0	17.6	16.5	15.6	15.2	14.9	14.5	14.2	13.9	13.7	13.4	13.2	12.9	12.3	9.8	7.4	WP316N		
22.9	22.9	22.0	21.5	21.2	21.0	20.5	20.0	19.6	19.2	18.8	18.5	18.1	17.8	15.8	12.3	9.8	7.4	WP316N		
22.9	20.0	17.9	16.3	15.3	14.6	WPS31726		
22.9	21.8	20.9	20.5	20.3	19.7	WPS31726		
20.0	17.3	15.6	14.3	13.3	12.6	12.3	12.1	11.9	11.8	11.6	11.5	11.4	11.3	11.2	11.1	9.8	7.4	WP317	A403	
20.0	20.0	20.0	19.3	18.0	17.0	16.6	16.3	16.1	15.9	15.7	15.6	15.4	15.3	15.1	12.4	9.8	7.4	WP317		
20.0	18.0	16.5	15.3	14.3	13.5	13.2	13.0	12.7	12.6	12.4	12.3	12.1	12.0	9.6	6.9	5.0	3.6	WP321		
20.0	20.0	19.1	18.7	18.7	18.3	17.9	17.5	17.2	16.9	16.7	16.5	16.4	16.2	9.6	6.9	5.0	3.6	WP321		
20.0	18.0	16.5	15.3	14.3	13.5	13.2	13.0	12.7	12.6	12.4	12.3	12.1	12.0	11.9	9.1	6.9	5.4	WP321H		
20.0	20.0	19.1	18.7	18.7	18.3	17.9	17.5	17.2	16.9	16.7	16.5	16.4	16.2	12.3	9.1	6.9	5.4	WP321H		
20.0	18.4	17.1	16.0	15.0	14.3	14.0	13.8	13.7	13.6	13.5	13.4	13.4	13.4	12.1	9.1	6.1	4.4	WP347	A403	
20.0	20.0	18.8	17.8	17.2	16.9	16.8	16.8	16.8	16.8	16.8	16.7	16.6	16.0	12.1	9.1	6.1	4.4	WP347		
20.0	18.4	17.1	16.0	15.0	14.3	14.0	13.8	13.7	13.6	13.5	13.4	13.4	13.4	13.4	13.3	10.5	7.9	WP347H		
20.0	20.0	18.8	17.8	17.1	16.9	16.8	16.8	16.8	16.8	16.8	16.7	16.6	16.4	16.2	14.1	10.5	7.9	WP347H		
20.0	18.4	17.1	16.0	15.0	14.3	14.0	13.8	13.7	13.6	13.5	13.4	13.4	13.4	12.1	9.1	6.1	4.4	WP348	A403	
20.0	20.0	18.8	17.8	17.2	16.9	16.8	16.8	16.8	16.8	16.8	16.7	16.6	16.0	12.1	9.1	6.1	4.4	WP348		
20.0	18.4	17.1	16.0	15.0	14.3	14.0	13.8	13.7	13.6	13.5	13.4	13.4	13.4	13.4	13.3	10.5	7.9	WP348H		
20.0	20.0	18.8	17.8	17.1	16.9	16.8	16.8	16.8	16.8	16.8	16.7	16.6	16.4	16.2	14.1	10.5	7.9	WP348H		
																			Ferritic/Austenitic	
25.7	25.7	24.8	23.9	23.3	23.1	S31803	A815
26.9	26.9	25.6	24.7	24.7	24.7	S32101	
27.1	27.1	26.2	25.2	24.6	24.3	S32205	
28.9	28.9	27.5	26.5	26.5	26.5	S32101	
																			Castings Austenitic	
16.0	13.3	12.0	11.0	10.4	9.8	9.6	9.4	9.2	9.0	CF3	A351
16.0	15.2	14.1	13.7	13.5	13.3	13.0	12.7	12.4	12.1	CF3	
17.7	15.6	14.0	12.9	12.1	11.5	11.2	10.9	CF3A	
17.7	16.8	15.6	15.1	15.0	15.0	14.8	CF3A	
16.0	13.8	12.4	11.4	10.6	10.1	9.8	9.7	9.5	9.4	9.3	CF3M	
16.0	16.0	15.5	15.4	14.3	13.6	13.3	13.0	12.8	12.7	12.5	CF3M	
16.0	13.3	12.0	11.0	10.4	9.8	9.6	9.4	9.2	9.0	8.8	8.6	8.5	8.3	7.6	6.0	4.8	3.8	CF8	A351	
16.0	15.2	14.1	13.7	13.5	13.3	13.0	12.7	12.4	12.1	11.9	11.7	11.4	9.8	7.6	6.0	4.8	3.8	CF8		
16.0	13.3	12.0	11.0	10.4	9.8	9.6	9.4	9.2	9.0	8.8	8.6	8.5	8.3	8.1	7.3	4.9	3.6	CF8C		
16.0	15.2	14.1	13.7	13.5	13.3	13.0	12.7	12.4	12.1	11.9	11.7	11.4	11.2	9.7	7.3	4.9	3.6	CF8C		
16.0	13.8	12.4	11.4	10.6	10.1	9.8	9.7	9.5	9.4	9.3	9.2	9.1	9.1	9.0	7.1	5.5	4.3	CF8M		
16.0	16.0	15.5	15.4	14.3	13.6	13.3	13.0	12.8	12.7	12.5	12.4	12.3	11.9	9.2	7.1	5.5	4.3	CF8M		

(16)

Table A-3 Stainless Steels (Cont'd)

Spec. No.	Type or Grade	Class	UNS Alloy No.	Nominal Composition	P-No.	Notes	Specified Minimum Tensile, ksi	Specified Minimum Yield, ksi	E or F
Castings (Cont'd)									
Austenitic (Cont'd)									
A351	CH8	...	J93400	25Cr-12Ni	8	(1)(5)(10)(17)	65	28	0.80
	CH8	...	J93400	25Cr-12Ni	8	(1)(5)(9)(10)(17)	65	28	0.80
	CH20	...	J93402	25Cr-12Ni	8	(1)(5)(10)(17)	70	30	0.80
	CH20	...	J93402	25Cr-12Ni	8	(1)(5)(9)(10)(17)	70	30	0.80
	CK20	...	J94202	25Cr-20Ni	8	(1)(5)(10)(17)	65	28	0.80
	CK20	...	J94202	25Cr-20Ni	8	(1)(5)(9)(10)(17)	65	28	0.80
Ferritic/Martensitic									
A217	CA15	...	J91150	13Cr- $\frac{1}{2}$ Mo	6	(1)(3)(5)	90	65	0.80
Bar									
Austenitic									
A479	N08904	44Fe-25Ni-21Cr-Mo	45	(1)	71	31	1.00
	304	...	S30400	18Cr-8Ni	8	(10)	75	30	1.00
	304	...	S30400	18Cr-8Ni	8	(9)(10)	75	30	1.00
	304H	...	S30409	18Cr-8Ni	8	...	75	30	1.00
	304H	...	S30409	18Cr-8Ni	8	(9)	75	30	1.00
A479	304L	...	S30403	18Cr-8Ni	8	(16)	70	25	1.00
	304L	...	S30403	18Cr-8Ni	8	(9)(16)	70	25	1.00
	304N	...	S30451	18Cr-8Ni-N	8	(10)	80	35	1.00
	304N	...	S30451	18Cr-8Ni-N	8	(9)(10)	80	35	1.00
A479	S30815	21Cr-11Ni-N	8	(1)	87	45	1.00
	S30815	21Cr-11Ni-N	8	(1)(9)	87	45	1.00
A479	310S	...	S31008	25Cr-20Ni	8	(10)(11)(15)	75	30	1.00
	310S	...	S31008	25Cr-20Ni	8	(10)(11)(14)	75	30	1.00
	310S	...	S31008	25Cr-20Ni	8	(9)(10)(11)	75	30	1.00
	S31254	20Cr-18Ni-6Mo	8	(1)	95	44	1.00
	S31254	20Cr-18Ni-6Mo	8	(1)(9)	95	44	1.00
A479	316	...	S31600	16Cr-12Ni-2Mo	8	(10)	75	30	1.00
	316	...	S31600	16Cr-12Ni-2Mo	8	(9)(10)	75	30	1.00
	316H	...	S31609	16Cr-12Ni-2Mo	8	...	75	30	1.00
	316H	...	S31609	16Cr-12Ni-2Mo	8	(9)	75	30	1.00
A479	316L	...	S31603	16Cr-12Ni-2Mo	8	(1)(16)(28)(29)	70	25	1.00
	316L	...	S31603	16Cr-12Ni-2Mo	8	(1)(9)(16)(28)(29)	70	25	1.00
	316N	...	S31651	16Cr-12Ni-2Mo	8	(10)	80	35	1.00
	316N	...	S31651	16Cr-12Ni-2Mo	8	(9)(10)	80	35	1.00
	317LMN	...	S31726	19Cr-15.5Ni-4Mo	8	(1)	80	35	1.00
	317LMN	...	S31726	19Cr-15.5Ni-4Mo	8	(1)(9)	80	35	1.00
A479	321	...	S32100	18Cr-10Ni-Ti	8	(10)	75	30	1.00
	321	...	S32100	18Cr-10Ni-Ti	8	(9)(10)	75	30	1.00
	321H	...	S32109	18Cr-10Ni-Ti	8	...	75	30	1.00
	321H	...	S32109	18Cr-10Ni-Ti	8	(9)	75	30	1.00
	S32550	25.5Cr-5.5Ni-3.5Mo-2Cu	10H	(1)(25)(26)	110	80	1.00
A479	347	...	S34700	18Cr-10Ni-Cb	8	(10)	75	30	1.00
	347	...	S34700	18Cr-10Ni-Cb	8	(9)(10)	75	30	1.00
	347H	...	S34709	18Cr-10Ni-Cb	8	...	75	30	1.00
	347H	...	S34709	18Cr-10Ni-Cb	8	(9)	75	30	1.00

Table A-3 Stainless Steels (Cont'd)

(16)

Maximum Allowable Stress Values in Tension, ksi, for Metal Temperature, °F, Not Exceeding																			Type or Grade	Spec. No.
100	200	300	400	500	600	650	700	750	800	850	900	950	1,000	1,050	1,100	1,150	1,200			
																			Castings (Cont'd)	
																			Austenitic (Cont'd)	
14.9	12.2	11.3	10.8	10.5	10.1	9.9	9.7	9.4	9.1	8.8	8.5	8.2	7.9	6.8	5.2	4.0	3.0	CH8	A351	
14.9	13.6	12.7	12.3	12.3	12.3	12.3	12.2	12.0	11.8	11.5	11.1	10.6	8.9	6.8	5.2	4.0	3.0	CH8		
16.0	13.1	12.1	11.6	11.2	10.8	10.6	10.4	10.1	9.8	9.5	9.1	8.8	8.5	6.8	5.2	4.0	3.0	CH20		
16.0	14.6	13.6	13.3	13.2	13.2	13.2	13.1	13.0	12.7	12.4	11.9	11.4	8.9	6.8	5.2	4.0	3.0	CH20		
14.9	12.2	11.3	10.8	10.5	10.1	9.9	9.7	9.4	9.1	8.8	8.5	8.2	7.9	7.6	6.8	5.8	4.8	CK20		
14.9	13.6	12.7	12.3	12.3	12.3	12.3	12.2	12.0	11.8	11.5	11.1	10.6	9.0	7.8	6.8	5.8	4.8	CK20		
																			Ferritic/Martensitic	
20.6	20.6	20.6	20.6	20.6	20.6	20.6	20.6	20.6	20.6	20.1	12.0	7.4	4.7	3.0	1.9	1.2	0.8	CA15	A217	
																			Bar	
																			Austenitic	
20.3	16.7	15.1	13.8	12.7	11.9	11.6	11.4	A479	
20.0	16.7	15.0	13.8	12.9	12.3	12.0	11.7	11.5	11.2	11.0	10.8	10.6	10.4	10.1	9.8	7.7	6.1	304		
20.0	20.0	18.9	18.3	17.5	16.6	16.2	15.8	15.5	15.2	14.9	14.6	14.3	14.0	12.4	9.8	7.7	6.1	304		
20.0	16.7	15.0	13.8	12.9	12.3	12.0	11.7	11.5	11.2	11.0	10.8	10.6	10.4	10.1	9.8	7.7	6.1	304H		
20.0	20.0	18.9	18.3	17.5	16.6	16.2	15.8	15.5	15.2	14.9	14.6	14.3	14.0	12.4	9.8	7.7	6.1	304H		
16.7	14.3	12.8	11.7	10.9	10.4	10.2	10.0	9.8	9.7	304L	A479	
16.7	16.7	16.7	15.8	14.7	14.0	13.7	13.5	13.3	13.0	304L		
22.9	19.1	16.7	15.1	14.0	13.3	13.0	12.8	12.5	12.3	12.1	11.8	11.6	11.3	11.0	9.8	7.7	6.1	304N		
22.9	22.9	21.7	20.3	18.9	17.9	17.5	17.2	16.9	16.6	16.3	16.0	15.6	15.2	12.4	9.8	7.7	6.1	304N		
24.9	24.7	22.0	19.9	18.5	17.7	17.4	17.2	17.0	16.8	16.6	16.4	16.2	14.9	11.6	9.0	6.9	5.2	...	A479	
24.9	24.7	23.3	22.4	21.8	21.4	21.2	21.0	20.8	20.6	20.3	20.0	19.1	14.9	11.6	9.0	6.9	5.2	...		
20.0	17.6	16.1	15.1	14.3	13.7	13.5	13.3	13.1	12.9	12.7	12.5	12.3	9.9	310S	A479	
20.0	17.6	16.1	15.1	14.3	13.7	13.5	13.3	13.1	12.9	12.7	12.5	12.3	9.9	310S		
20.0	20.0	20.0	19.9	19.3	18.5	18.2	17.9	17.7	17.4	17.2	16.9	15.9	9.9	310S		
26.9	23.9	21.4	19.8	18.6	17.9	17.6	17.4	17.3		
26.9	26.9	25.5	24.3	23.5	23.0	22.8	22.7	22.6		
20.0	17.3	15.6	14.3	13.3	12.6	12.3	12.1	11.9	11.8	11.6	11.5	11.4	11.3	11.2	11.1	9.8	7.4	316	A479	
20.0	20.0	20.0	19.3	18.0	17.0	16.6	16.3	16.1	15.9	15.7	15.6	15.4	15.3	15.1	12.4	9.8	7.4	316		
20.0	17.3	15.6	14.3	13.3	12.6	12.3	12.1	11.9	11.8	11.6	11.5	11.4	11.3	11.2	11.1	9.8	7.4	316H		
20.0	20.0	20.0	19.3	18.0	17.0	16.6	16.3	16.1	15.9	15.7	15.6	15.4	15.3	15.1	12.4	9.8	7.4	316H		
16.7	14.1	12.7	11.7	10.9	10.4	10.2	10.0	9.8	9.6	9.4	9.2	9.0	8.8	8.6	8.4	8.3	6.4	316L	A479	
16.7	16.7	16.0	15.6	14.8	14.0	13.8	13.5	13.2	13.0	12.7	12.4	12.1	11.9	11.6	11.4	8.8	6.4	316L		
22.9	20.7	19.0	17.6	16.5	15.6	15.2	14.9	14.5	14.2	13.9	13.7	13.4	13.2	12.9	12.3	9.8	7.4	316N		
22.9	22.9	22.0	21.5	21.2	21.0	20.5	20.0	19.6	19.2	18.8	18.5	18.1	17.8	15.8	12.3	9.8	7.4	316N		
22.9	20.0	17.9	16.3	15.3	14.6	317LMN		
22.9	21.8	20.9	20.5	20.3	19.7	317LMN		
20.0	18.0	16.5	15.3	14.3	13.5	13.2	13.0	12.7	12.6	12.4	12.3	12.1	12.0	9.6	6.9	5.0	3.6	321	A479	
20.0	20.0	19.1	18.7	18.7	18.3	17.9	17.5	17.2	16.9	16.7	16.5	16.4	14.9	9.6	6.9	5.0	3.6	321		
20.0	18.0	16.5	15.3	14.3	13.5	13.2	13.0	12.7	12.6	12.4	12.3	12.1	12.0	11.9	9.1	6.9	5.4	321H		
20.0	20.0	19.1	18.7	18.7	18.3	17.9	17.5	17.2	16.9	16.7	16.5	16.4	16.2	12.3	9.1	6.9	5.4	321H		
31.4	31.3	29.5	28.6	28.2		
20.0	18.4	17.1	16.0	15.0	14.3	14.0	13.8	13.7	13.6	13.5	13.4	13.4	13.4	12.1	9.1	6.1	4.4	347	A479	
20.0	20.0	18.8	17.8	17.2	16.9	16.8	16.8	16.8	16.8	16.8	16.7	16.6	16.0	12.1	9.1	6.1	4.4	347		
20.0	18.4	17.1	16.0	15.0	14.3	14.0	13.8	13.7	13.6	13.5	13.4	13.4	13.4	13.4	13.3	10.5	7.9	347H		
20.0	20.0	18.8	17.8	17.1	16.9	16.8	16.8	16.8	16.8	16.8	16.7	16.6	16.4	16.2	14.1	10.5	7.9	347H		

(16)

Table A-3 Stainless Steels (Cont'd)

Spec. No.	Type or Grade	Class	UNS Alloy No.	Nominal Composition	P-No.	Notes	Specified Minimum Tensile, ksi	Specified Minimum Yield, ksi	E or F
Bar (Cont'd)									
Austenitic (Cont'd)									
A479	348	...	S34800	18Cr-10Ni-Cb	8	(10)	75	30	1.00
	348	...	S34800	18Cr-10Ni-Cb	8	(9)(10)	75	30	1.00
	348H	...	S34809	18Cr-10Ni-Cb	8	...	75	30	1.00
	348H	...	S34809	18Cr-10Ni-Cb	8	(9)	75	30	1.00
Ferritic/Martensitic									
A479	XM-27	...	S44627	27Cr-1Mo	10I	(2)	65	40	1.00
Ferritic/Austenitic									
A479	S31803	...	S31803	22Cr-5.5Ni-3Mo-N	10H	(1)(23)(24)	90	65	1.00
	S32101	...	S32101	21Cr-5Mn-1.5Ni-Cu-N	10H	(1)(23)(24)	94	65	1.00
	2205	...	S32205	25Cr-7Ni-4Mo-N	10H	(1)(22)(23)	95	65	1.00
	S32750	...	S32750	25Cr-7Ni-4Mo-N	10H	(1)(22)(23)	116	80	1.00

GENERAL NOTES:

- The tabulated specifications are ANSI/ASTM or ASTM. For ASME Boiler and Pressure Vessel Code applications, see related specifications in Section II of the ASME Code.
- The stress values in this Table may be interpolated to determine values for intermediate temperatures.
- The P-Numbers indicated in this Table are identical to those adopted by the ASME Boiler and Pressure Vessel Code. Qualification of welding procedures, welders, and welding operators is required and shall comply with the ASME Boiler and Pressure Vessel Code, Section IX, except as modified by para. 127.5.
- Tensile strengths and allowable stresses shown in "ksi" are "thousands of pounds per square inch."
- The materials listed in this Table shall not be used at design temperatures above those for which allowable stress values are given herein or in Table A-8.
- The tabulated stress values are $S \times E$ (weld joint efficiency factor) or $S \times F$ (material quality factor), as applicable. Weld joint efficiency factors are shown in Table 102.4.3.
- Pressure-temperature ratings of piping components, as published in standards referenced in this Code, may be used for components meeting the requirements of those standards. The allowable stress values given in this Table are for use in designing piping components which are not manufactured in accordance with referenced standards.
- The tabulated stress values that are shown in italics are at temperatures in the range where creep and stress rupture strength govern the selection of stresses.
- See para. 124.1.2 for lower temperature limits.

NOTES:

- THIS MATERIAL IS NOT ACCEPTABLE FOR USE ON BOILER EXTERNAL PIPING — SEE FIG. 100.1.2(A.1), FIG. 100.1.2(A.2), FIG. 100.1.2(B.1), FIG. 100.1.2(B.2), AND FIG. 100.1.2(B.3).
- Use of this material at temperatures above 650°F is not approved because of the possibility of temper embrittlement.
- This steel may be expected to develop embrittlement at room temperature after service at temperatures above 700°F. Consequently, its use at higher temperatures is not recommended unless due caution is observed.
- For fittings made from A182 forgings over 5 in. in thickness, the allowable stress values tabulated shall be reduced by the ratio of 70 divided by 75.
- The material quality factors and allowable stress values for these materials may be increased in accordance with para. 102.4.6.
- Tensile strengths in parentheses are expected minimum values.
- See MSS SP-43 for requirements for lightweight stainless steel fittings. MSS SP-43 Schedule 5S fittings shall not be used for design temperatures above 400°F. MSS SP-43 Schedule 10S fittings shall not be used for design temperatures above 750°F.
- The material quality factor for centrifugally cast pipe (0.85) is based on all surfaces being machined after heat treatment. The surface finish, after machining, shall be 250 μ in. arithmetic average deviation or smoother.
- Due to relatively low yield strength of these materials, these higher allowable stress values were established at temperatures where the short time tensile properties govern to permit the use of these alloys where slightly greater deformation is acceptable. These stress values exceed 67% but do not exceed 90% of the yield strength at temperature. Use of these stress values may result in dimensional changes due to permanent strain. These values should not be used for the flanges of gasketed joints or other applications where slight amounts of distortion can cause leakage or malfunction.
- The allowable stress values tabulated for temperatures over 1,000°F apply only if the carbon content of the material is 0.04% or higher.

Table A-3 Stainless Steels (Cont'd)

Maximum Allowable Stress Values in Tension, ksi, for Metal Temperature, °F, Not Exceeding																			Type or Grade	Spec. No.
100	200	300	400	500	600	650	700	750	800	850	900	950	1,000	1,050	1,100	1,150	1,200			
																			Bar (Cont'd)	
																			Austenitic (Cont'd)	
20.0	18.4	17.1	16.0	15.0	14.3	14.0	13.8	13.7	13.6	13.5	13.4	13.4	13.4	12.1	9.1	6.1	4.4	348	A479	
20.0	20.0	18.8	17.8	17.2	16.9	16.8	16.8	16.8	16.8	16.8	16.7	16.6	16.0	12.1	9.1	6.1	4.4	348		
20.0	18.4	17.1	16.0	15.0	14.3	14.0	13.8	13.7	13.6	13.5	13.4	13.4	13.4	13.4	13.3	10.5	7.9	348H		
20.0	20.0	18.8	17.8	17.1	16.9	16.8	16.8	16.8	16.8	16.8	16.7	16.6	16.4	16.2	14.1	10.5	7.9	348H		
																			Ferritic/Martensitic	
18.6	18.6	18.3	18.1	18.1	18.1	18.1	XM-27	A479	
																			Ferritic/Austenitic	
25.7	25.7	24.8	23.9	23.3	23.1	S31803	A479	
26.9	26.9	25.6	24.7	24.7	24.7	S32101		
27.1	27.1	26.2	25.2	24.6	24.3	2205		
33.1	33.0	31.2	30.1	29.6	29.4	S32750		

NOTES (Cont'd):

- (1) The allowable stress values tabulated for temperatures over 1,000°F apply only if the material is heat treated by heating to a minimum temperature of 1,900°F and quenching in water or rapidly cooling by other means.
- (12) These allowable stress values apply to forgings over 5 in. in thickness.
- (13) The allowable stress values tabulated for temperatures over 800°F apply only if the carbon content of the material is 0.04% or higher.
- (14) These allowable stress values shall be used only when the grain size of the material is ASTM No. 6 or coarser.
- (15) These allowable stress values shall be used when the grain size of the material is finer than ASTM No. 6 or when the grain size has not been determined.
- (16) Use of external pressure charts for material in the form of barstock is permitted for stiffening rings only.
- (17) At the ferrite levels tabulated below, these materials will have significant reductions in Charpy V-notch toughness values at room temperature and below following service exposure at the indicated temperatures. This reduction indicates the potential for brittle fracture with high rate loading in the presence of sharp notches or cracks.

Ferrite Content	Service Temperature
5% and less	1,100°F and above
10%	900°F and above
15%	800°F and above
20%	700°F and above
25%—30%	600°F and above
35%—40%	500°F and above

- (18) The stress values at 1,050°F and above shall be used only when the grain size is ASTM No. 6 or coarser.
- (19) These allowable stress values apply for single or double butt welded pipe with radiography per para. 136.4.5.
- (20) These allowable stress values apply for double butt welded pipe, without radiography.
- (21) These allowable stress values apply for single butt welded pipe, without radiography.
- (22) Any heat treatment applied to this material shall be performed at 1,880°F to 2,060°F, followed by a rapid cool.
- (16) (23) The use of this material is limited to 600°F (315°C). This material may exhibit embrittlement at room temperature after moderately elevated temperature service. Cold work (strain hardening) such as that introduced during tube bending and certain manufacturing and assembly processes can make UNS S32750 more susceptible to embrittlement when exposed to temperatures in excess of 480°F (250°C).
- (24) Any heat treatment applied to this material shall be performed at 1,870°F to 2,010°F, followed by a rapid cool. For A182, A240, and A479 material, this is more restrictive than the material specification and shall be met.
- (25) Openings \geq 4 in. shall conform to para. 127.4.8, except that full-penetration welds shall be used and separate reinforcing pads shall not be used.
- (26) This steel may be expected to develop embrittlement after exposure to temperatures above 500°F for prolonged times. See ASME Boiler and Pressure Vessel Code, Section II, Part D, Appendix A, A-340 and A-360.
- (27) These allowable stress values apply only to forgings 5 in. in thickness and under.
- (28) The stress values at temperatures above 1,000°F apply only if Supplementary Requirement S1 has been specified.
- (29) The material shall have an ASTM grain size of 7 or coarser for use at 1,000°F (550°C) and above.

(16)

Table A-4 Nickel and High Nickel Alloys

Spec. No.	UNS Alloy No.	Temper or Condition	Nominal Composition	P-No.	Notes	Specified Minimum Tensile, ksi	Specified Minimum Yield, ksi	E or F
Seamless Pipe and Tube								
B161	N02200	Annealed	Ni	41	(1)(5)	55	15	1.00
	N02200	Annealed	Ni	41	(1)(6)	55	12	1.00
	N02200	Str. rel.	Ni	41	(1)	65	40	1.00
B161	N02201	Annealed	Ni-Low C	41	(1)(5)	50	12	1.00
	N02201	Annealed	Ni-Low C	41	(1)(6)	50	10	1.00
	N02201	Str. rel.	Ni-Low C	41	(1)	60	30	1.00
B163	N08800	Annealed	Ni-Cr-Fe	45	(1)(7)	75	30	1.00
	N08800	Annealed	Ni-Cr-Fe	45	(1)(2)(7)	75	30	1.00
	N08810	Annealed	Ni-Cr-Fe	45	(1)	65	25	1.00
	N08810	Annealed	Ni-Cr-Fe	45	(1)(2)	65	25	1.00
B165	N04400	Annealed	Ni-Cu	42	(1)(5)	70	28	1.00
	N04400	Annealed	Ni-Cu	42	(1)(6)	70	25	1.00
	N04400	Str. rel.	Ni-Cu	42	(1)(2)(3)	85	35	1.00
B167	N06600	H.F./ann.	Ni-Cr-Fe	43	(1)(5)	80	30	1.00
	N06600	H.F./ann.	Ni-Cr-Fe	43	(1)(2)(5)	75	30	1.00
	N06600	H.F./ann.	Ni-Cr-Fe	43	(1)(6)	75	25	1.00
	N06600	H.F./ann.	Ni-Cr-Fe	43	(1)(2)(6)	80	25	1.00
B167	N06600	C.D./ann.	Ni-Cr-Fe	43	(1)(5)	80	35	1.00
	N06600	C.D./ann.	Ni-Cr-Fe	43	(1)(2)(5)	80	35	1.00
	N06600	C.D./ann.	Ni-Cr-Fe	43	(1)(6)	80	30	1.00
	N06600	C.D./ann.	Ni-Cr-Fe	43	(1)(2)(6)	80	30	1.00
B167	N06617	Annealed	52Ni-22Cr-13Co-9Mo	43	(1)(7)	95	35	1.00
	N06617	Annealed	52Ni-22Cr-13Co-9Mo	43	(1)(2)(7)	95	35	1.00
	N06690	C.W./ann.	58Ni-29Cr-9Fe	43	(7)(23)	85	35	1.00
	N06690	C.W./ann.	58Ni-29Cr-9Fe	43	(2)(7)(23)	85	35	1.00
B407	N08800	C.D./ann.	Ni-Cr-Fe	45	(7)	75	30	1.00
	N08800	C.D./ann.	Ni-Cr-Fe	45	(2)(7)	75	30	1.00
	N08810	Annealed	Ni-Cr-Fe	45	(7)	65	25	1.00
	N08810	Annealed	Ni-Cr-Fe	45	(2)(7)	65	25	1.00
B423	N08825	C.W./ann.	Ni-Fe-Cr-Mo-Cu	45	(1)(7)	85	35	1.00
	N08825	C.W./ann.	Ni-Fe-Cr-Mo-Cu	45	(1)(2)(7)	85	35	1.00
B444	N06625	Sol. ann.	Ni-Cr-Mo-Cb	43	(14)(18)	100	40	1.00
	N06625	Annealed	Ni-Cr-Mo-Cb	43	(2)(14)	120	60	1.00
B622	N06022	Sol. ann.	Ni-Mo-Cr-Low C	44	(1)(12)	100	45	1.00
	N06022	Sol. ann.	Ni-Mo-Cr-Low C	44	(1)(2)(12)	100	45	1.00
	N10276	Sol. ann.	Low C-Ni-Mo-Cr	43	(1)(12)	100	41	1.00
	N10276	Sol. ann.	Low C-Ni-Mo-Cr	43	(1)(2)(12)	100	41	1.00
	R30556	Annealed	Ni-Fe-Cr-Co-Mo-W	45	(1)	100	45	1.00
	R30556	Annealed	Ni-Fe-Cr-Co-Mo-W	45	(1)(2)	100	45	1.00
B677	N08925	Annealed	Ni-Fe-Cr-Mo-Cu-Low C	45	(1)	87	43	1.00
	N08925	Annealed	Ni-Fe-Cr-Mo-Cu-Low C	45	(1)(2)	87	43	1.00
	N08926	Annealed	Ni-Fe-Cr-Mo-Cu-N-Low C	45	(1)(19)(20)	94	43	1.00
	N08926	Annealed	Ni-Fe-Cr-Mo-Cu-N-Low C	45	(1)(2)(19)(20)	94	43	1.00

Table A-4 Nickel and High Nickel Alloys

Maximum Allowable Stress Values in Tension, ksi, for Metal Temperature, °F, Not Exceeding																			UNS Alloy No.	Spec. No.
100	200	300	400	500	600	650	700	750	800	850	900	950	1,000	1,050	1,100	1,150	1,200			
Seamless Pipe and Tube																				
10.0	10.0	10.0	10.0	10.0	10.0	N02200	B161
8.0	8.0	8.0	8.0	8.0	8.0	N02200	
18.6	18.6	18.6	18.6	18.3	17.7	N02200	
8.0	7.7	7.5	7.5	7.5	7.5	7.5	7.4	7.4	7.2	5.8	4.5	3.7	3.0	2.4	2.0	1.5	1.2	N02201	B161	
6.7	6.4	6.3	6.2	6.2	6.2	6.2	6.2	6.1	6.0	5.8	4.5	3.7	3.0	2.4	2.0	1.5	1.2	N02201		
17.1	17.1	17.0	17.0	16.8	16.3	N02201		
20.0	18.5	17.8	17.2	16.8	16.3	16.1	15.9	15.7	15.5	15.3	15.1	14.9	14.7	14.5	13.0	9.8	6.6	N08800	B163	
20.0	20.0	20.0	20.0	20.0	20.0	20.0	20.0	20.0	20.0	20.0	20.0	20.0	19.9	17.0	13.0	9.8	6.6	N08800		
16.7	15.4	14.4	13.6	12.9	12.2	11.9	11.6	11.4	11.1	10.9	10.7	10.5	10.4	10.2	10.0	9.3	7.4	N08810		
16.7	16.7	16.7	16.7	16.7	16.7	16.1	15.7	15.3	15.0	14.7	14.5	14.2	14.0	13.8	11.6	9.3	7.4	N08810		
18.7	16.4	15.2	14.7	14.7	14.7	14.7	14.6	14.5	14.3	11.0	8.0	N04400	B165	
16.7	14.6	13.6	13.2	13.1	13.1	13.1	13.0	12.9	12.7	11.0	8.0	N04400		
24.3	24.3	24.3	24.3	24.3	N04400		
20.0	19.1	18.3	17.5	16.8	16.2	15.9	15.7	15.5	15.2	15.1	14.9	10.6	7.0	4.5	3.0	2.2	2.0	N06600	B167	
20.0	20.0	20.0	20.0	20.0	20.0	20.0	20.0	20.0	20.0	20.0	16.0	10.6	7.0	4.5	3.0	2.2	2.0	N06600		
16.7	15.9	15.2	14.6	14.0	13.5	13.3	13.1	12.9	12.7	12.5	12.4	10.6	7.0	4.5	3.0	2.2	2.0	N06600		
16.7	16.7	16.7	16.7	16.7	16.7	16.7	16.7	16.7	16.7	16.7	16.0	10.6	7.0	4.5	3.0	2.2	2.0	N06600		
22.9	21.3	20.8	20.5	20.2	19.9	19.8	19.6	19.4	19.1	18.7	16.0	10.6	7.0	4.5	3.0	2.2	2.0	N06600	B167	
22.9	22.9	22.9	22.9	22.9	22.9	22.9	22.9	22.9	22.9	22.9	22.4	16.0	10.6	7.0	4.5	3.0	2.2	2.0	N06600	
20.0	19.1	18.3	17.5	16.8	16.2	15.9	15.7	15.5	15.2	15.1	14.9	10.6	7.0	4.5	3.0	2.2	2.0	N06600		
20.0	20.0	20.0	20.0	20.0	20.0	20.0	20.0	20.0	20.0	20.0	16.0	10.6	7.0	4.5	3.0	2.2	2.0	N06600		
23.3	20.8	19.2	18.1	17.2	16.6	16.4	16.2	16.0	15.9	15.8	15.7	15.6	15.5	15.4	15.4	15.3	15.3	N06617	B167	
23.3	23.3	23.3	23.3	23.3	22.5	22.1	21.9	21.7	21.5	21.3	21.2	21.0	20.9	20.9	20.8	20.7	18.1	N06617		
23.3	21.1	19.9	19.1	18.6	18.4	18.4	18.4	18.4	18.4	18.4	18.3	16.5	11.6	9.0	6.5	4.5	3.0	N06690		
23.3	23.3	23.3	23.3	23.1	22.9	22.9	22.8	22.7	22.6	22.5	22.2	16.5	11.6	9.0	6.5	4.5	3.0	N06690		
20.0	18.5	17.8	17.2	16.8	16.3	16.1	15.9	15.7	15.5	15.3	15.1	14.9	14.7	14.5	13.0	9.8	6.6	N08800	B407	
20.0	20.0	20.0	20.0	20.0	20.0	20.0	20.0	20.0	20.0	20.0	20.0	20.0	19.9	17.0	13.0	9.8	6.6	N08800		
16.7	15.4	14.4	13.6	12.9	12.2	11.9	11.6	11.4	11.1	10.9	10.7	10.5	10.4	10.2	10.0	9.3	7.4	N08810		
16.7	16.7	16.7	16.7	16.7	16.5	16.1	15.7	15.3	15.0	14.7	14.5	14.2	14.0	13.8	11.6	9.3	7.4	N08810		
23.3	21.4	20.3	19.4	18.5	17.8	17.5	17.3	17.2	17.0	N08825	B423	
23.3	23.3	23.3	23.3	23.3	23.3	23.3	23.3	23.3	23.2	23.0	N08825		
26.7	24.9	23.6	22.6	21.8	21.1	20.8	20.6	20.3	20.1	20.0	19.8	19.7	19.5	19.4	19.4	N06625	B444	
34.3	34.3	34.3	33.6	32.9	32.4	32.1	31.8	31.5	31.2	30.9	30.6	30.3	29.9	29.5	29.0	N06625		
28.6	26.7	24.6	22.9	21.5	20.4	20.0	19.6	19.3	19.0	N06022	B622	
28.6	28.6	28.2	27.2	26.5	26.0	25.8	25.6	25.4	25.3	N06022		
27.3	24.9	23.0	21.3	19.9	18.8	18.2	17.8	17.4	17.1	16.9	16.7	16.6	16.5	N10276		
27.3	27.3	27.3	27.3	26.9	25.2	24.6	24.0	23.5	23.1	22.8	22.6	22.4	22.3	N10276		
28.6	25.6	23.1	21.3	20.1	19.3	18.9	18.7	18.4	18.2	18.0	17.8	17.6	17.5	17.3	17.1	16.9	13.6	R30556		
28.6	28.6	28.0	27.1	26.4	26.0	25.6	25.2	24.9	24.6	24.3	24.1	23.8	23.6	23.3	21.2	17.0	13.6	R30556		
24.9	23.2	21.3	19.8	18.3	17.3	17.0	16.9	16.9	16.9	N08925	B677	
24.9	24.9	23.9	23.0	22.1	21.4	21.1	20.8	20.4	20.1	N08925		
26.9	24.1	21.5	19.7	18.7	18.0	17.7	17.5	17.4	N08926		
26.9	26.9	26.2	24.8	23.7	22.8	22.4	22.0	21.6	N08926		

Table A-4 Nickel and High Nickel Alloys (Cont'd)

Spec. No.	UNS Alloy No.	Temper or Condition	Nominal Composition	P-No.	Notes	Specified Minimum Tensile, ksi	Specified Minimum Yield, ksi	E or F
Seamless Pipe and Tube (Cont'd)								
B690	N08367	Sol. ann.	Fe-Ni-Cr-Mo-Cu-N	45	(1)(8)(22)	95	45	1.00
	N08367	Sol. ann.	Fe-Ni-Cr-Mo-Cu-N	45	(1)(2)(8)(22)	95	45	1.00
	N08367	Sol. ann.	Fe-Ni-Cr-Mo-Cu-N	45	(1)(21)	100	45	1.00
	N08367	Sol. ann.	Fe-Ni-Cr-Mo-Cu-N	45	(1)(2)(21)	100	45	1.00
B729	N08020	Annealed	Ni-Fe-Cr-Mo-Cu-Cb	45	(1)	80	35	1.00
	N08020	Annealed	Ni-Fe-Cr-Mo-Cu-Cb	45	(1)(2)	80	35	1.00
Welded Pipe and Tube								
B464	N08020	Annealed	Ni-Fe-Cr-Mo-Cu-Cb	45	(1)	80	35	0.85
	N08020	Annealed	Ni-Fe-Cr-Mo-Cu-Cb	45	(1)(2)	80	35	0.85
B468	N08020	Annealed	Ni-Fe-Cr-Mo-Cu-Cb	45	(1)	80	35	0.85
	N08020	Annealed	Ni-Fe-Cr-Mo-Cu-Cb	45	(1)(2)	80	35	0.85
B546	N06617	Annealed	52Ni-22Cr-13Co-9Mo	43	(1)(7)	95	35	0.85
	N06617	Annealed	52Ni-22Cr-13Co-9Mo	43	(1)(2)(7)	95	35	0.85
B619	N06022	Sol. ann.	Ni-Mo-Cr-Low C	44	(1)(12)	100	45	0.85
	N06022	Sol. ann.	Ni-Mo-Cr-Low C	44	(1)(2)(12)	100	45	0.85
	N10276	Sol. ann.	Low C-Ni-Mo-Cr	43	(1)(12)	100	41	0.85
	N10276	Sol. ann.	Low C-Ni-Mo-Cr	43	(1)(2)(12)	100	41	0.85
	R30556	Annealed	Ni-Fe-Cr-Co-Mo-W	45	(1)	100	45	0.85
	R30556	Annealed	Ni-Fe-Cr-Co-Mo-W	45	(1)(2)	100	45	0.85
B626	N06022	Sol. ann.	Ni-Mo-Cr-Low C	44	(1)(12)	100	45	0.85
	N06022	Sol. ann.	Ni-Mo-Cr-Low C	44	(1)(2)(12)	100	45	0.85
	N10276	Sol. ann.	Low C-Ni-Mo-Cr	43	(1)(12)	100	41	0.85
	N10276	Sol. ann.	Low C-Ni-Mo-Cr	43	(1)(2)(12)	100	41	0.85
	R30556	Annealed	Ni-Fe-Cr-Co-Mo-W	45	(1)	100	45	0.85
	R30556	Annealed	Ni-Fe-Cr-Co-Mo-W	45	(1)(2)	100	45	0.85
B673	N08925	Annealed	Ni-Fe-Cr-Mo-Cu-Low C	45	(1)	87	43	0.85
	N08925	Annealed	Ni-Fe-Cr-Mo-Cu-Low C	45	(1)(2)	87	43	0.85
	N08926	Annealed	Ni-Fe-Cr-Mo-Cu-N-Low C	45	(1)(19)(20)	94	43	0.85
	N08926	Annealed	Ni-Fe-Cr-Mo-Cu-N-Low C	45	(1)(2)(19)(20)	94	43	0.85
B674	N08925	Annealed	Ni-Fe-Cr-Mo-Cu-Low C	45	(1)	87	43	0.85
	N08925	Annealed	Ni-Fe-Cr-Mo-Cu-Low C	45	(1)(2)	87	43	0.85
	N08926	Annealed	Ni-Fe-Cr-Mo-Cu-N-Low C	45	(1)(19)(20)	94	43	0.85
	N08926	Annealed	Ni-Fe-Cr-Mo-Cu-N-Low C	45	(1)(2)(19)(20)	94	43	0.85
B675	N08367	Sol. ann.	Fe-Ni-Cr-Mo-Cu-N	45	(1)(8)(22)	95	45	0.85
	N08367	Sol. ann.	Fe-Ni-Cr-Mo-Cu-N	45	(1)(2)(8)(22)	95	45	0.85
	N08367	Sol. ann.	Fe-Ni-Cr-Mo-Cu-N	45	(1)(8)(21)	100	45	0.85
	N08367	Sol. ann.	Fe-Ni-Cr-Mo-Cu-N	45	(1)(2)(8)(21)	100	45	0.85
B676	N08367	Sol. ann.	Fe-Ni-Cr-Mo-Cu-N	45	(1)(8)(22)	95	45	0.85
	N08367	Sol. ann.	Fe-Ni-Cr-Mo-Cu-N	45	(1)(2)(8)(22)	95	45	0.85
	N08367	Sol. ann.	Fe-Ni-Cr-Mo-Cu-N	45	(1)(8)(21)	100	45	0.85
	N08367	Sol. ann.	Fe-Ni-Cr-Mo-Cu-N	45	(1)(2)(8)(21)	100	45	0.85

Table A-4 Nickel and High Nickel Alloys (Cont'd)

Maximum Allowable Stress Values in Tension, ksi, for Metal Temperature, °F, Not Exceeding																		UNS Alloy No.	Spec. No.
100	200	300	400	500	600	650	700	750	800	850	900	950	1,000	1,050	1,100	1,150	1,200		
Seamless Pipe and Tube (Cont'd)																			
27.1	26.2	23.8	21.9	20.5	19.4	19.0	18.6	18.3	18.0	N08367	B690
27.1	27.1	25.7	24.6	23.8	23.3	23.1	22.9	22.8	22.6	N08367	
28.6	26.2	23.8	21.9	20.5	19.4	19.0	18.6	18.3	18.0	N08367	
28.6	28.6	27.0	25.8	25.0	24.5	24.3	24.1	24.0	23.8	N08367	
22.9	20.6	19.7	18.9	18.2	17.7	17.5	17.4	17.2	16.8	N08020	B729
22.9	22.9	22.6	22.2	22.1	22.1	22.0	21.9	21.8	21.8	N08020	
Welded Pipe and Tube																			
19.4	17.5	16.7	16.1	15.5	15.0	14.9	14.8	14.6	14.3	N08020	B464
19.4	19.4	19.2	18.8	18.8	18.8	18.7	18.6	18.5	18.5	N08020	
19.4	17.5	16.7	16.1	15.5	15.0	14.9	14.8	14.6	14.3	N08020	B468
19.4	19.4	19.2	18.8	18.8	18.8	18.7	18.6	18.5	18.5	N08020	
19.8	17.7	16.3	15.4	14.6	14.1	13.9	13.8	13.6	13.5	13.4	13.3	13.3	13.2	13.1	13.1	13.0	13.0	N06617	B546
19.8	19.8	19.8	19.8	19.8	19.1	18.8	18.6	18.4	18.3	18.1	18.0	17.9	17.8	17.8	17.7	17.6	15.4	N06617	
24.3	22.7	20.9	19.4	18.3	17.4	17.0	16.7	16.4	16.2	N06022	B619
24.3	22.7	20.9	19.4	18.3	17.4	17.0	16.7	16.4	16.2	N06022	
23.2	21.2	19.6	18.1	16.9	16.0	15.5	15.1	14.8	14.5	14.4	14.2	14.1	14.0	N10276	
23.2	23.2	23.2	23.2	22.9	21.4	20.9	20.4	20.0	19.6	19.4	19.2	19.0	19.0	N10276	
24.3	21.8	19.6	18.1	17.1	16.4	16.1	15.9	15.7	15.5	15.3	15.2	15.0	14.8	14.7	14.5	14.4	11.6	R30556	
24.3	24.3	23.8	23.0	22.5	22.1	21.7	21.4	21.1	20.9	20.7	20.5	20.2	20.0	19.8	18.0	14.4	11.6	R30556	
24.3	24.3	23.9	23.1	22.6	22.1	21.9	21.8	21.6	21.5	N06022	B626
24.3	24.3	23.9	23.1	22.6	22.1	21.9	21.8	21.6	21.5	N06022	
23.2	21.2	19.6	18.1	16.9	16.0	15.5	15.1	14.8	14.5	14.4	14.2	14.1	14.0	N10276	
23.2	23.2	23.2	23.2	22.9	21.4	20.9	20.4	20.0	19.6	19.4	19.2	19.0	19.0	N10276	
24.3	21.8	19.6	18.1	17.1	16.4	16.1	15.9	15.7	15.5	15.3	15.2	15.0	14.8	14.7	14.5	14.4	11.6	R30556	
24.3	24.3	23.8	23.0	22.5	22.1	21.7	21.4	21.1	20.9	20.7	20.5	20.2	20.0	19.8	18.0	14.4	11.6	R30556	
21.1	19.7	18.1	16.8	15.6	14.7	14.4	14.4	14.4	14.4	N08925	B673
21.1	21.1	20.4	19.5	18.8	18.2	17.9	17.7	17.4	17.0	N08925	
22.9	20.5	18.3	16.7	15.9	15.3	15.0	14.9	14.8	N08926	
22.9	22.9	22.3	21.1	20.1	19.4	19.0	18.7	18.4	N08926	
21.1	19.7	18.1	16.8	15.6	14.7	14.4	14.4	14.4	14.4	N08925	B674
21.1	21.1	20.4	19.5	18.8	18.2	17.9	17.7	17.4	17.0	N08925	
22.9	20.5	18.3	16.7	15.9	15.3	15.0	14.9	14.8	N08926	
22.9	22.9	22.3	21.1	20.1	19.4	19.0	18.7	18.4	N08926	
23.1	22.2	20.2	18.7	17.4	16.5	16.1	15.8	15.5	15.3	N08367	B675
23.1	23.1	21.8	20.9	20.2	19.8	19.6	19.5	19.4	19.2	N08367	
24.3	22.2	20.2	18.7	17.4	16.5	16.1	15.8	15.5	15.3	N08367	
24.3	24.3	23.0	22.0	21.3	20.8	20.7	20.5	20.4	20.2	N08367	
23.1	22.2	20.2	18.7	17.4	16.5	16.1	15.8	15.5	15.3	N08367	B676
23.1	23.1	21.8	20.9	20.2	19.8	19.6	19.5	19.4	19.2	N08367	
24.3	22.2	20.2	18.7	17.4	16.5	16.1	15.8	15.5	15.3	N08367	
24.3	24.3	23.0	22.0	21.3	20.8	20.7	20.5	20.4	20.2	N08367	

(16)

Table A-4 Nickel and High Nickel Alloys (Cont'd)

Spec. No.	UNS Alloy No.	Temper or Condition	Nominal Composition	P-No.	Notes	Specified Minimum Tensile, ksi	Specified Minimum Yield, ksi	E or F
Welded Pipe and Tube (Cont'd)								
B704	N06625	Annealed	Ni-Cr-Mo-Cb	43	(14)	120	60	0.85
B705	N06625	Annealed	Ni-Cr-Mo-Cb	43	(14)	120	60	0.85
B804	N08367	Sol. ann.	Fe-Ni-Cr-Mo-Cu-N	45	(1)(8)	95	45	0.85
	N08367	Sol. ann.	Fe-Ni-Cr-Mo-Cu-N	45	(1)(2)(8)	95	45	0.85
	N08367	Sol. ann.	Fe-Ni-Cr-Mo-Cu-N	45	(1)(8)(21)	100	45	0.85
	N08367	Sol. ann.	Fe-Ni-Cr-Mo-Cu-N	45	(1)(2)(8)(21)	100	45	0.85
Plate, Sheet, and Strip								
B168	N06600	Annealed	Ni-Cr-Fe	43	(1)	80	35	1.00
	N06600	Annealed	Ni-Cr-Fe	43	(1)(2)	80	35	1.00
	N06600	Hot rolled	Ni-Cr-Fe	43	(1)(4)	85	35	1.00
	N06600	Hot rolled	Ni-Cr-Fe	43	(1)(2)(4)	85	35	1.00
B168	N06617	Annealed	52Ni-22Cr-13Co-9Mo	43	(1)(7)	95	35	1.00
	N06617	Annealed	52Ni-22Cr-13Co-9Mo	43	(1)(2)(7)	95	35	1.00
	N06690	Annealed	58Ni-29Cr-9Fe	43	(7)	85	35	1.00
	N06690	Annealed	58Ni-29Cr-9Fe	43	(2)(7)	85	35	1.00
B409	N08800	Annealed	Ni-Cr-Fe	45	(4)(7)	75	30	1.00
	N08800	Annealed	Ni-Cr-Fe	45	(2)(4)(7)	75	30	1.00
	N08810	Annealed	Ni-Cr-Fe	45	(4)(7)	65	25	1.00
	N08810	Annealed	Ni-Cr-Fe	45	(2)(4)(7)	65	25	1.00
B424	N08825	Annealed	Ni-Fe-Cr-Mo-Cu	45	(1)(7)	85	35	1.00
	N08825	Annealed	Ni-Fe-Cr-Mo-Cu	45	(1)(2)(7)	85	35	1.00
B435	R30556	Annealed	Ni-Fe-Cr-Co-Mo-W	45	(1)	100	45	1.00
	R30556	Annealed	Ni-Fe-Cr-Co-Mo-W	45	(1)(2)	100	45	1.00
B443	N06625	Sol. ann.	Ni-Cr-Mo-Cb	43	(14)(18)	100	40	1.00
	N06625	Annealed	Ni-Cr-Mo-Cb	43	(14)	110	55	1.00
	N06625	Annealed	Ni-Cr-Mo-Cb	43	(14)(15)	120	60	1.00
B463	N08020	Annealed	Ni-Fe-Cr-Mo-Cu-Cb	45	(1)	80	35	1.00
	N08020	Annealed	Ni-Fe-Cr-Mo-Cu-Cb	45	(1)(12)	80	35	1.00
B575	N06022	Sol. ann.	Ni-Mo-Cr-Low C	44	(1)(12)	100	45	1.00
	N06022	Sol. ann.	Ni-Mo-Cr-Low C	44	(1)(2)(12)	100	45	1.00
	N10276	Sol. ann.	Low C-Ni-Mo-Cr	43	(1)(12)	100	41	1.00
	N10276	Sol. ann.	Low C-Ni-Mo-Cr	43	(1)(2)(12)	100	41	1.00
B625	N08925	Annealed	Ni-Fe-Cr-Mo-Cu-Low C	45	(1)	87	43	1.00
	N08925	Annealed	Ni-Fe-Cr-Mo-Cu-Low C	45	(1)(2)	87	43	1.00
	N08926	Annealed	Ni-Fe-Cr-Mo-Cu-N-Low C	45	(1)(19)(20)	94	43	1.00
	N08926	Annealed	Ni-Fe-Cr-Mo-Cu-N-Low C	45	(1)(2)(19)(20)	94	43	1.00
B688	N08367	Sol. ann.	Fe-Ni-Cr-Mo-Cu-N	45	(1)(7)(11)(22)	95	45	1.00
	N08367	Sol. ann.	Fe-Ni-Cr-Mo-Cu-N	45	(1)(2)(7)(11)(22)	95	45	1.00
	N08367	Sol. ann.	Fe-Ni-Cr-Mo-Cu-N	45	(1)(7)(10)(21)	100	45	1.00
	N08367	Sol. ann.	Fe-Ni-Cr-Mo-Cu-N	45	(1)(2)(7)(10)(21)	100	45	1.00

Table A-4 Nickel and High Nickel Alloys (Cont'd)

(16)

Maximum Allowable Stress Values in Tension, ksi, for Metal Temperature, °F, Not Exceeding																			UNS Alloy No.	Spec. No.
100	200	300	400	500	600	650	700	750	800	850	900	950	1,000	1,050	1,100	1,150	1,200			
																			Welded Pipe and Tube (Cont'd)	
29.1	29.1	29.1	28.5	28.0	27.5	27.3	27.0	26.8	26.5	26.3	26.0	25.7	25.4	25.1	24.7	N06625	B704	
29.1	29.1	29.1	28.5	28.0	27.5	27.3	27.0	26.8	26.5	26.3	26.0	25.7	25.4	25.1	24.7	N06625	B705	
23.1	22.2	20.2	18.7	17.4	16.5	16.1	15.8	15.5	15.3	N08367	B804	
23.1	23.1	21.8	20.9	20.2	19.8	19.6	19.5	19.4	19.2	N08367		
24.3	22.2	20.2	18.7	17.4	16.5	16.1	15.8	15.5	15.3	N08367		
24.3	24.3	23.0	22.0	21.3	20.8	20.7	20.5	20.4	20.2	N08367		
																			Plate, Sheet, and Strip	
22.9	21.3	20.8	20.5	20.2	19.9	19.8	19.6	19.4	19.1	18.7	16.0	10.6	7.0	4.5	3.0	2.2	2.0	N06600	B168	
22.9	22.9	22.9	22.9	22.9	22.9	22.9	22.9	22.9	22.9	22.4	16.0	10.6	7.0	4.5	3.0	2.2	2.0	N06600		
23.3	22.1	21.5	21.3	21.3	21.2	21.1	21.0	20.8	20.5	20.1	19.7	19.3	14.5	10.3	7.2	5.8	5.5	N06600		
23.3	23.3	23.3	23.3	23.3	23.3	23.3	23.3	23.3	23.3	23.3	23.3	23.3	14.5	10.3	7.2	5.8	5.5	N06600		
23.3	20.8	19.2	18.1	17.2	16.6	16.4	16.2	16.0	15.9	15.8	15.7	15.6	15.5	15.4	15.4	15.3	15.3	N06617	B168	
23.3	23.3	23.3	23.3	23.3	22.5	22.1	21.9	21.7	21.5	21.3	21.2	21.0	20.9	20.9	20.8	20.7	18.1	N06617		
23.3	23.3	23.3	23.3	23.1	22.9	22.9	22.8	22.7	22.6	22.5	22.2	16.5	11.6	9.0	6.5	4.5	3.0	N06690		
23.3	21.1	19.9	19.1	18.6	18.4	18.4	18.4	18.4	18.4	18.4	18.3	16.5	11.6	9.0	6.5	4.5	3.0	N06690		
20.0	18.5	17.8	17.2	16.8	16.3	16.1	15.9	15.7	15.5	15.3	15.1	14.9	14.7	14.5	13.0	9.8	6.6	N08800	B409	
20.0	20.0	20.0	20.0	20.0	20.0	20.0	20.0	20.0	20.0	20.0	20.0	20.0	19.9	17.0	13.0	9.8	6.6	N08800		
16.7	15.4	14.4	13.6	12.9	12.2	11.9	11.6	11.4	11.1	10.9	10.7	10.5	10.4	10.2	10.0	9.3	7.4	N08810		
16.7	16.7	16.7	16.7	16.7	16.5	16.1	15.7	15.3	15.0	14.7	14.5	14.2	14.0	13.8	11.6	9.3	7.4	N08810		
23.3	21.4	20.3	19.4	18.5	17.8	17.5	17.3	17.2	17.0	N08825	B424	
23.3	23.3	23.3	23.3	23.3	23.3	23.3	23.3	23.2	23.0	N08825		
28.6	25.6	23.1	21.3	20.1	19.3	18.9	18.7	18.4	18.2	18.0	17.8	17.6	17.5	17.3	17.1	16.9	13.6	R30556	B435	
28.6	28.6	28.0	27.1	26.4	26.0	25.6	25.2	24.9	24.6	24.3	24.1	23.8	23.6	23.3	21.2	17.0	13.6	R30556		
26.7	24.9	23.6	22.6	21.8	21.1	20.8	20.6	20.3	20.1	20.0	19.8	19.7	19.5	19.4	19.4	N06625	B443	
31.4	31.4	31.4	30.8	30.2	29.7	29.4	29.1	28.9	28.6	28.3	28.0	27.7	27.4	27.0	26.6	N06625		
34.3	34.3	34.3	33.6	32.9	32.4	32.1	31.8	31.5	31.2	30.9	30.6	30.3	29.9	29.5	29.0	N06625		
22.9	20.6	19.7	18.9	18.2	17.7	17.5	17.4	17.2	16.8	N08020	B463	
22.9	22.9	22.9	22.6	22.2	22.1	22.1	22.0	21.9	21.8	N08020		
28.6	28.6	28.2	27.2	26.5	26.0	25.8	25.6	25.4	25.3	N06022	B575	
28.6	28.6	28.2	27.2	26.5	26.0	25.8	25.6	25.4	25.3	N06022		
27.3	24.9	23.0	21.3	19.9	18.8	18.2	17.8	17.4	17.1	16.8	16.7	16.5	16.5	N10276		
27.3	27.3	27.3	27.3	26.9	25.2	24.6	24.0	23.5	23.1	22.8	22.6	22.4	22.3	N10276		
24.9	23.2	21.3	19.8	18.3	17.3	17.0	16.9	16.9	16.9	N08925	B625	
24.9	24.9	23.9	23.0	22.1	21.4	21.1	20.8	20.4	20.1	N08925		
26.9	24.1	21.5	19.7	18.7	18.0	17.7	17.5	17.4	N08926		
26.9	26.9	26.2	24.8	23.7	22.8	22.4	22.0	21.6	N08926		
27.1	26.2	23.8	21.9	20.5	19.4	19.0	18.6	18.3	18.0	N08367	B688	
27.1	27.1	25.7	24.6	23.8	23.3	23.1	22.9	22.8	22.6	N08367		
28.6	26.2	23.8	21.9	20.5	19.4	19.0	18.6	18.3	18.0	N08367		
28.6	28.6	27.0	25.8	25.0	24.5	24.3	24.1	24.0	23.8	N08367		

(16)

Table A-4 Nickel and High Nickel Alloys (Cont'd)

Spec. No.	UNS Alloy No.	Temper or Condition	Nominal Composition	P-No.	Notes	Specified Minimum Tensile, ksi	Specified Minimum Yield, ksi	E or F
Bars, Rods, Shapes, and Forgings								
B166	N06617	Annealed	52Ni-22Cr-13Co-9Mo	43	(1)(7)	95	35	1.00
	N06617	Annealed	52Ni-22Cr-13Co-9Mo	43	(1)(2)(7)	95	35	1.00
	N06690	Annealed	58Ni-29Cr-9Fe	43	(7)	85	35	1.00
	N06690	Annealed	58Ni-29Cr-9Fe	43	(2)(7)	85	35	1.00
B408	N08800	Annealed	Ni-Cr-Fe	45	(7)	75	30	1.00
	N08800	Annealed	Ni-Cr-Fe	45	(2)(7)	75	30	1.00
	N08810	Annealed	Ni-Cr-Fe	45	(7)	65	25	1.00
	N08810	Annealed	Ni-Cr-Fe	45	(2)(7)	65	25	1.00
B425	N08825	Annealed	Ni-Fe-Cr-Mo-Cu	45	(1)(7)	85	35	1.00
	N08825	Annealed	Ni-Fe-Cr-Mo-Cu	45	(1)(2)(7)	85	35	1.00
B446	N06625	Sol. ann.	Ni-Cr-Mo-Cb	43	(14)(18)	100	40	1.00
	N06625	Annealed	Ni-Cr-Mo-Cb	43	(2)(14)(16)	110	50	1.00
	N06625	Annealed	Ni-Cr-Mo-Cb	43	(2)(14)(15)(17)	120	60	1.00
B462	N08020	Annealed	Ni-Fe-Cr-Mo-Cu-Cb	45	(1)	80	35	1.00
	N08020	Annealed	Ni-Fe-Cr-Mo-Cu-Cb	45	(1)(2)	80	35	1.00
B473	N08020	Annealed	Cr-Ni-Fe-Mo-Cu-Cb	45	(1)	80	35	1.00
	N08020	Annealed	Cr-Ni-Fe-Mo-Cu-Cb	45	(1)(2)	80	35	1.00
B564	N06617	Annealed	52Ni-22Cr-13Co-9Mo	43	(1)(7)	95	35	1.00
	N06617	Annealed	52Ni-22Cr-13Co-9Mo	43	(1)(2)(7)	95	35	1.00
	N06625	Annealed	Ni-Cr-Mo-Cb	43	(2)(14)(16)	110	50	1.00
	N06625	Annealed	Ni-Cr-Mo-Cb	43	(2)(14)(15)(17)	120	60	1.00
B564	N08367	Sol. ann.	Fe-Ni-Cr-Mo-Cu-N	45	(1)(8)(22)	95	45	1.00
	N08367	Sol. ann.	Fe-Ni-Cr-Mo-Cu-N	45	(1)(2)(8)(22)	95	45	1.00
	N08800	Annealed	Ni-Cr-Fe	45	(1)	75	30	1.00
	N08800	Annealed	Ni-Cr-Fe	45	(1)(2)	75	30	1.00
	N08810	Annealed	Ni-Cr-Fe	45	(1)	65	25	1.00
	N08810	Annealed	Ni-Cr-Fe	45	(1)(2)	65	25	1.00
B572	R30556	Annealed	Ni-Fe-Cr-Co-Mo-W	45	(1)	100	45	1.00
	R30556	Annealed	Ni-Fe-Cr-Co-Mo-W	45	(1)(2)	100	45	1.00
B574	N06022	Sol. ann.	Ni-Mo-Cr-Low C	44	(1)(12)	100	45	1.00
	N06022	Sol. ann.	Ni-Mo-Cr-Low C	44	(1)(2)(12)	100	45	1.00
	N10276	Sol. ann.	Low C-Ni-Mo-Cr	43	(1)(12)	100	41	1.00
	N10276	Sol. ann.	Low C-Ni-Mo-Cr	43	(1)(2)(12)	100	41	1.00
B649	N08925	Annealed	Ni-Fe-Cr-Mo-Cu-Low C	45	(1)	87	43	1.00
	N08925	Annealed	Ni-Fe-Cr-Mo-Cu-Low C	45	(1)(2)	87	43	1.00
	N08926	Annealed	Ni-Fe-Cr-Mo-Cu-N-Low C	...	(1)	94	43	1.00
	N08926	Annealed	Ni-Fe-Cr-Mo-Cu-N-Low C	...	(1)(2)	94	43	1.00
B691	N08367	Sol. ann.	Fe-Ni-Cr-Mo-Cu-N	45	(1)(8)(22)	95	45	1.00
	N08367	Sol. ann.	Fe-Ni-Cr-Mo-Cu-N	45	(1)(2)(8)(22)	95	45	1.00

Table A-4 Nickel and High Nickel Alloys (Cont'd)

(16)

Maximum Allowable Stress Values in Tension, ksi, for Metal Temperature, °F, Not Exceeding																			UNS Alloy No.	Spec. No.
100	200	300	400	500	600	650	700	750	800	850	900	950	1,000	1,050	1,100	1,150	1,200			
Bars, Rods, Shapes, and Forgings																				
23.3	20.8	19.2	18.1	17.2	16.6	16.4	16.2	16.0	15.9	15.8	15.7	15.6	15.5	15.4	15.4	15.3	15.3	N06617	B166	
23.3	23.3	23.3	23.3	23.3	22.5	22.1	21.9	21.7	21.5	21.3	21.2	21.0	20.9	20.9	20.8	20.7	18.1	N06617		
23.3	23.3	23.3	23.3	23.1	22.9	22.9	22.8	22.7	22.6	22.5	22.2	16.5	11.6	9.0	6.5	4.5	3.0	N06690		
23.3	21.1	19.9	19.1	18.6	18.4	18.4	18.4	18.4	18.4	18.4	18.3	16.5	11.6	9.0	6.5	4.5	3.0	N06690		
20.0	18.5	17.8	17.2	16.8	16.3	16.1	15.9	15.7	15.5	15.3	15.1	14.9	14.7	14.5	13.0	9.8	6.6	N08800	B408	
20.0	20.0	20.0	20.0	20.0	20.0	20.0	20.0	20.0	20.0	20.0	20.0	20.0	19.9	17.0	13.0	9.8	6.6	N08800		
16.7	15.4	14.4	13.6	12.9	12.2	11.9	11.6	11.4	11.1	10.9	10.7	10.5	10.4	10.2	10.0	9.3	7.4	N08810		
16.7	16.7	16.7	16.7	16.7	16.5	16.1	15.7	15.3	15.0	14.7	14.5	14.2	14.0	13.8	11.6	9.3	7.4	N08810		
23.3	21.4	20.3	19.4	18.5	17.8	17.5	17.3	17.2	17.0	N08825	B425	
23.3	23.3	23.3	23.3	23.3	23.3	23.3	23.3	23.2	23.0	N08825		
26.7	24.9	23.6	22.6	21.8	21.1	20.8	20.6	20.3	20.1	20.0	19.8	19.7	19.5	19.4	19.4	N06625	B446	
31.4	31.4	31.4	30.8	30.2	29.7	29.4	29.1	28.9	28.6	28.3	28.0	27.7	27.4	27.0	26.6	N06625		
34.3	34.3	34.3	33.6	32.9	32.4	32.1	31.8	31.5	31.2	30.9	30.6	30.3	29.9	29.5	29.0	N06625		
22.9	20.6	19.7	18.9	18.2	17.7	17.5	17.4	17.2	16.8	N08020	B462	
22.9	22.9	22.6	22.2	22.1	22.1	22.0	21.9	21.8	21.8	N08020		
22.9	20.6	19.7	18.9	18.2	17.7	17.5	17.4	17.2	16.8	N08020	B473	
22.9	22.9	22.6	22.2	22.1	22.1	22.0	21.9	21.8	21.8	N08020		
23.3	20.8	19.2	18.1	17.2	16.6	16.4	16.2	16.0	15.9	15.8	15.7	15.6	15.5	15.4	15.4	15.3	15.3	N06617	B564	
23.3	23.3	23.3	23.3	23.3	22.5	22.1	21.9	21.7	21.5	21.3	21.2	21.0	20.9	20.9	20.8	20.7	18.1	N06617		
31.4	31.4	31.4	30.8	30.2	29.7	29.4	29.1	28.9	28.6	28.3	28.0	27.7	27.4	27.0	26.6	N06625		
34.3	34.3	34.3	33.6	32.9	32.4	32.1	31.8	31.5	31.2	30.9	30.6	30.3	29.9	29.5	29.0	N06625		
27.1	26.2	23.8	21.9	20.5	19.4	19.0	18.6	18.3	18.0	N08367	B564	
27.1	27.1	25.7	24.6	23.8	23.3	23.1	22.9	22.8	22.6	N08367		
20.0	18.5	17.8	17.2	16.8	16.3	16.1	15.9	15.7	15.5	15.3	15.1	14.9	14.7	14.5	13.0	9.8	6.6	N08800		
20.0	20.0	20.0	20.0	20.0	20.0	20.0	20.0	20.0	20.0	20.0	20.0	20.0	19.9	17.0	13.0	9.8	6.6	N08800		
16.7	15.4	14.4	13.6	12.9	12.2	11.9	11.6	11.4	11.1	10.9	10.7	10.5	10.4	10.2	10.0	9.3	7.4	N08810		
16.7	16.7	16.7	16.7	16.7	16.5	16.1	15.7	15.3	15.0	14.7	14.5	14.2	14.0	13.8	11.6	9.3	7.4	N08810		
28.6	25.6	23.1	21.3	20.1	19.3	18.9	18.7	18.4	18.2	18.0	17.8	17.6	17.5	17.3	17.1	16.9	13.6	R30556	B572	
28.6	28.6	28.0	27.1	26.4	26.0	25.6	25.2	24.9	24.6	24.3	24.1	23.8	23.6	23.3	21.2	17.0	13.6	R30556		
28.6	22.9	22.9	22.6	22.2	22.1	22.1	22.0	21.9	21.8	N06022	B574	
28.6	28.6	28.2	27.2	26.5	26.0	25.8	25.6	25.4	25.3	N06022		
27.3	24.9	23.0	21.3	19.9	18.8	18.2	17.8	17.4	17.1	16.9	16.7	16.6	16.5	N10276		
27.3	27.3	27.3	27.3	26.9	25.2	24.6	24.0	23.5	23.1	22.8	22.6	22.4	22.3	N10276		
24.9	23.2	21.3	19.8	18.3	17.3	17.0	16.9	16.9	16.9	N08925	B649	
24.9	24.9	23.9	23.0	22.1	21.4	21.1	20.8	20.4	20.1	N08925		
26.9	24.1	21.5	19.7	18.7	18.0	17.7	17.5	17.4	N08926		
26.9	26.9	26.2	24.8	23.7	22.8	22.4	22.0	21.6	N08926		
27.1	26.2	23.8	21.9	20.5	19.4	19.0	18.6	18.3	18.0	N08367	B691	
27.1	27.1	25.7	24.6	23.8	23.3	23.1	22.9	22.8	22.6	N08367		

(16)

Table A-4 Nickel and High Nickel Alloys (Cont'd)

Spec. No.	UNS Alloy No.	Temper or Condition	Nominal Composition	P-No.	Notes	Specified Minimum Tensile, ksi	Specified Minimum Yield, ksi	E or F
Seamless Fittings								
B366	N06022	Sol. ann.	Low C-Ni-Mo-Cr	44	(1)(12)	100	45	1.00
	N06022	Sol. ann.	Low C-Ni-Mo-Cr	44	(1)(2)(12)	100	45	1.00
	N06625	Annealed	Ni-Cr-Mo-Cb	43	(1)(14)	110	50	1.00
B366	N08020	Annealed	Cr-Ni-Fe-Mo-Cu-Cb	45	(1)	80	35	1.00
	N08020	Annealed	Cr-Ni-Fe-Mo-Cu-Cb	45	(1)(2)	80	35	1.00
	N08367	Annealed	Fe-Ni-Cr-Mo-N	45	(1)(8)(22)	95	45	1.00
	N08367	Annealed	Fe-Ni-Cr-Mo-N	45	(1)(2)(8)(22)	95	45	1.00
B366	N08925	Annealed	Low C-Ni-Fe-Cr-Mo-Cu	45	(1)	87	43	1.00
	N08925	Annealed	Low C-Ni-Fe-Cr-Mo-Cu	45	(1)(2)	87	43	1.00
	N08926	Annealed	Low C-Ni-Fe-Cr-Mo-Cu-N	45	(1)	94	43	1.00
	N08926	Annealed	Low C-Ni-Fe-Cr-Mo-Cu-N	45	(1)(2)	94	43	1.00
B366	N10276	Sol. ann.	Low C-Ni-Mo-Cr	43	(1)(12)	100	41	1.00
	N10276	Sol. ann.	Low C-Ni-Mo-Cr	43	(1)(2)(12)	100	41	1.00
	R30556	Annealed	Ni-Fe-Cr-Co-Mo-W	45	(1)	100	45	1.00
	R30556	Annealed	Ni-Fe-Cr-Co-Mo-W	45	(1)(2)	100	45	1.00
B462	N08367	Sol. ann.	Fe-Ni-Cr-Mo-N	45	(1)(8)(22)	95	45	1.00
	N08367	Sol. ann.	Fe-Ni-Cr-Mo-N	45	(1)(2)(8)(22)	95	45	1.00
Welded Fittings								
B366	N06022	Sol. ann.	Low C-Ni-Mo-Cr	44	(1)(12)	100	45	0.85
	N06022	Sol. ann.	Low C-Ni-Mo-Cr	44	(1)(12)(13)	100	45	1.00
	N06022	Sol. ann.	Low C-Ni-Mo-Cr	44	(1)(2)(12)	100	45	0.85
	N06022	Sol. ann.	Low C-Ni-Mo-Cr	44	(1)(2)(12)(13)	100	45	1.00
	N06625	Annealed	Ni-Cr-Mo-Cb	43	(14)	110	50	0.85
	N06625	Annealed	Ni-Cr-Mo-Cb	43	(13)(14)	110	50	1.00
B366	N08020	Annealed	Cr-Ni-Fe-Mo-Cu-Cb	45	(1)	80	35	0.85
	N08020	Annealed	Cr-Ni-Fe-Mo-Cu-Cb	45	(1)(13)	80	35	1.00
	N08020	Annealed	Cr-Ni-Fe-Mo-Cu-Cb	45	(1)(2)	80	35	0.85
	N08020	Annealed	Cr-Ni-Fe-Mo-Cu-Cb	45	(1)(2)(13)	80	35	1.00
B366	N08367	Sol. ann.	Fe-Ni-Cr-Mo-N	45	(1)(8)(22)	95	45	0.85
	N08367	Sol. ann.	Fe-Ni-Cr-Mo-N	45	(1)(8)(13)(22)	95	45	1.00
	N08367	Sol. ann.	Fe-Ni-Cr-Mo-N	45	(1)(2)(8)(22)	95	45	0.85
	N08367	Sol. ann.	Fe-Ni-Cr-Mo-N	45	(1)(2)(8)(13)(22)	95	45	1.00
B366	N08925	Annealed	Low C-Ni-Fe-Cr-Mo-Cu	45	(1)	87	43	0.85
	N08925	Annealed	Low C-Ni-Fe-Cr-Mo-Cu	45	(1)(13)	87	43	1.00
	N08925	Annealed	Low C-Ni-Fe-Cr-Mo-Cu	45	(1)(2)	87	43	0.85
	N08925	Annealed	Low C-Ni-Fe-Cr-Mo-Cu	45	(1)(2)(13)	87	43	1.00
B366	N08926	Annealed	Low C-Ni-Fe-Cr-Mo-Cu-N	45	(1)(19)(20)	94	43	0.85
	N08926	Annealed	Low C-Ni-Fe-Cr-Mo-Cu-N	45	(1)(13)	94	43	1.00
	N08926	Annealed	Low C-Ni-Fe-Cr-Mo-Cu-N	45	(1)(2)(19)(20)	94	43	0.85
	N08926	Annealed	Low C-Ni-Fe-Cr-Mo-Cu-N	45	(1)(2)(13)	94	43	1.00
B366	N10276	Sol. ann.	Low C-Ni-Mo-Cr	43	(1)(12)	100	41	0.85
	N10276	Sol. ann.	Low C-Ni-Mo-Cr	43	(1)(12)(13)	100	41	1.00
	N10276	Sol. ann.	Low C-Ni-Mo-Cr	43	(1)(2)(12)	100	41	0.85
	N10276	Sol. ann.	Low C-Ni-Mo-Cr	43	(1)(2)(12)(13)	100	41	1.00

Table A-4 Nickel and High Nickel Alloys (Cont'd)

(16)

Maximum Allowable Stress Values in Tension, ksi, for Metal Temperature, °F, Not Exceeding																		UNS Alloy No.	Spec. No.
100	200	300	400	500	600	650	700	750	800	850	900	950	1,000	1,050	1,100	1,150	1,200		
																		Seamless Fittings	
28.6	26.7	24.6	22.9	21.5	20.4	20.0	19.6	19.3	19.0	N06022	B366
28.6	28.6	28.2	27.2	26.5	26.0	25.8	25.6	25.4	25.3	N06022	
31.4	31.4	31.4	30.8	30.2	29.7	29.4	29.1	28.9	28.6	28.3	28.0	27.7	27.4	27.0	26.6	21.0	13.2	N06625	
22.9	20.6	19.7	18.9	18.2	17.7	17.5	17.4	17.2	16.8	N08020	B366
22.9	22.9	22.6	22.2	22.1	22.1	22.0	21.9	21.8	21.8	N08020	
27.1	26.2	23.8	21.9	20.5	19.4	19.0	18.6	18.3	18.0	N08367	
27.1	27.1	25.7	24.6	23.8	23.3	23.1	22.9	22.8	22.6	N08367	
24.9	23.2	21.3	19.8	18.3	17.3	17.0	16.9	16.9	16.9	N08925	B366
24.9	24.9	23.0	23.0	22.1	21.4	21.1	20.8	20.4	20.1	N08925	
26.9	24.1	21.5	19.7	18.7	18.0	17.7	17.5	17.4	N08926	
26.9	26.9	26.2	24.8	23.7	22.8	22.4	22.0	21.6	N08926	
27.3	24.9	23.0	21.3	19.9	18.8	18.2	17.8	17.4	17.1	16.9	16.7	16.6	16.5	N10276	B366
27.3	27.3	27.3	27.3	26.9	25.2	24.6	24.0	23.5	23.1	22.8	22.6	22.4	22.3	N10276	
28.6	25.6	23.1	21.3	20.1	19.3	18.9	18.7	18.4	18.2	18.0	17.8	17.6	17.5	17.3	17.1	16.9	13.6	R30556	
28.6	28.6	28.0	27.1	26.4	26.0	25.6	25.2	24.9	24.6	24.3	24.1	23.8	23.6	23.3	21.2	17.0	13.6	R30556	
27.1	26.2	23.8	21.9	20.5	19.4	19.0	18.6	18.3	18.0	N08367	B462
27.1	27.1	25.7	24.6	23.8	23.3	23.1	22.9	22.8	22.6	N08367	
																		Welded Fittings	
24.3	22.7	20.9	19.4	18.3	17.4	17.0	16.7	16.4	16.2	N06022	B366
28.6	26.7	24.6	22.9	21.5	20.4	20.0	19.6	19.3	19.0	N06022	
24.3	24.3	23.9	23.1	22.6	22.1	21.9	21.8	21.6	21.5	N06022	
28.6	28.6	28.2	27.2	26.5	26.0	25.8	25.6	25.4	25.3	N06022	
26.7	26.7	26.7	26.2	25.7	25.2	25.0	24.7	24.6	24.3	24.1	23.8	23.5	23.3	23.0	22.6	N06625	
31.4	31.4	31.4	30.8	30.2	29.7	29.4	29.1	28.9	28.6	28.3	28.0	27.7	27.4	27.0	26.6	N06625	
19.4	17.5	16.8	16.1	15.5	15.0	14.9	14.8	14.6	14.3	N08020	B366
22.9	20.6	19.7	18.9	18.2	17.7	17.5	17.4	17.2	16.8	N08020	
19.4	19.4	19.2	18.8	18.8	18.8	18.7	18.6	18.5	18.5	N08020	
22.9	22.9	22.6	22.2	22.1	22.1	22.0	21.9	21.8	21.8	N08020	
23.1	22.2	20.2	18.7	17.4	16.5	16.1	15.8	15.5	15.3	N08367	B366
27.1	26.2	23.8	21.9	20.5	19.4	19.0	18.6	18.3	18.0	N08367	
23.1	23.1	21.8	20.9	20.2	19.8	19.6	19.5	19.4	19.2	N08367	
27.1	27.1	25.7	24.6	23.8	23.3	23.1	22.9	22.8	22.6	N08367	
21.1	19.7	18.1	16.8	15.6	14.7	14.4	14.4	14.4	14.4	N08925	B366
24.9	23.2	21.3	19.8	18.3	17.3	17.0	16.9	16.9	16.9	N08925	
21.1	21.1	20.4	19.5	18.8	18.2	17.9	17.7	17.4	17.0	N08925	
24.9	24.9	23.9	23.0	22.1	21.4	21.1	20.8	20.4	20.1	N08925	
22.9	20.5	18.3	16.7	15.9	15.3	15.0	14.9	14.8	N08926	B366
26.9	24.1	21.5	19.7	18.7	18.0	17.7	17.5	17.4	N08926	
22.9	22.9	22.3	21.1	20.1	19.4	19.0	18.7	18.4	N08926	
26.9	26.9	26.2	24.8	23.7	22.8	22.4	22.0	21.6	N08926	
23.2	21.2	19.6	18.1	16.9	16.0	15.5	15.1	14.8	14.5	14.4	14.2	14.1	14.0	N10276	B366
27.3	24.9	23.0	21.3	19.9	18.8	18.2	17.8	17.4	17.1	16.9	16.7	16.6	16.5	N10276	
23.2	23.2	23.2	23.2	22.9	21.4	20.9	20.4	20.0	19.6	19.4	19.2	19.0	19.0	N10276	
27.3	27.3	27.3	27.3	26.9	25.2	24.6	24.0	23.5	23.1	22.8	22.6	22.4	22.3	N10276	

Table A-4 Nickel and High Nickel Alloys (Cont'd)

Spec. No.	UNS Alloy No.	Temper or Condition	Nominal Composition	P-No.	Notes	Specified Minimum Tensile, ksi	Specified Minimum Yield, ksi	<i>E</i> or <i>F</i>
Welded Fittings (Cont'd)								
B366	R30556	Annealed	Ni-Fe-Cr-Co-Mo-W	45	(1)	100	45	0.85
	R30556	Annealed	Ni-Fe-Cr-Co-Mo-W	45	(1)(13)	100	45	1.00
	R30556	Annealed	Ni-Fe-Cr-Co-Mo-W	45	(1)(2)	100	45	0.85
	R30556	Annealed	Ni-Fe-Cr-Co-Mo-W	45	(1)(2)(13)	100	45	1.00

GENERAL NOTES:

- The tabulated specifications are ANSI/ASTM or ASTM. For ASME Boiler and Pressure Vessel Code applications, see related specifications in Section II of the ASME Code.
- The stress values in this Table may be interpolated to determine values for intermediate temperatures.
- The P-Numbers indicated in this Table are identical to those adopted by the ASME Boiler and Pressure Vessel Code. Qualification of welding procedures, welders, and welding operators is required and shall comply with the ASME Boiler and Pressure Vessel Code, Section IX, except as modified by para. 127.5.
- Tensile strengths and allowable stresses shown in "ksi" are "thousands of pounds per square inch."
- The materials listed in this table shall not be used at design temperatures above those for which allowable stress values are given herein or in Table A-8.
- The tabulated stress values are $S \times E$ (weld joint efficiency factor) or $S \times F$ (material quality factor), as applicable. Weld joint efficiency factors are shown in Table 102.4.3.
- Pressure-temperature ratings of piping components, as published in standards referenced in this Code, may be used for components meeting the requirements of those standards. The allowable stress values given in this Table are for use in designing piping components that are not manufactured in accordance with referenced standards.
- The y coefficient = 0.4 except where Note (7) applies [see Table 104.1.2(A)].
- The tabulated stress values that are shown in italics are at temperatures in the range where creep and stress rupture strength govern the selection of stresses.
- See para. 124.1.2 for lower temperature limits.

NOTES:

- THIS MATERIAL IS NOT ACCEPTABLE FOR USE ON BOILER EXTERNAL PIPING — SEE FIG. 100.1.2(A.1), FIG. 100.1.2(A.2), FIG. 100.1.2(B.1), FIG. 100.1.2(B.2), AND FIG. 100.1.2(B.3).
- Due to the relatively low yield strengths of these materials, these higher allowable stress values were established at temperatures where the short time tensile properties govern to permit the use of these alloys where slightly greater deformation is acceptable. These stress values exceed 67% but do not exceed 90% of the yield strength at temperature. Use of these values may result in dimensional changes due to permanent strain. These values should not be used for flanges of gasketed joints or other applications where slight amounts of distortion can cause leakage or malfunction.
- The maximum temperature is limited to 500°F because harder temper adversely affects design stress in the creep rupture temperature range.

Table A-4 Nickel and High Nickel Alloys (Cont'd)

Maximum Allowable Stress Values in Tension, ksi, for Metal Temperature, °F, Not Exceeding																		UNS Alloy No.	Spec. No.
100	200	300	400	500	600	650	700	750	800	850	900	950	1,000	1,050	1,100	1,150	1,200		
																		Welded Fittings (Cont'd)	
24.3	21.8	19.6	18.1	17.1	16.4	16.1	15.9	15.7	15.5	15.3	15.2	15.0	14.8	14.7	14.5	14.4	11.6	R30556	B366
28.6	25.6	23.1	21.3	20.1	19.3	18.9	18.7	18.4	18.2	18.0	17.8	17.6	17.5	17.3	17.1	16.9	13.6	R30556	
24.3	24.3	23.8	23.0	22.5	22.1	21.7	21.4	21.1	20.9	20.7	20.5	20.2	20.0	19.8	18.0	14.4	11.6	R30556	
28.6	28.6	28.0	27.1	26.4	26.0	25.6	25.2	24.9	24.6	24.3	24.1	23.8	23.6	23.3	21.2	17.0	13.6	R30556	

NOTES (Cont'd):

- (4) These values may be used for plate material only.
- (5) These values apply to sizes NPS 5 and smaller.
- (6) These values apply to sizes larger than NPS 5.
- (7) See Table 104.1.2(A) for γ coefficient value.
- (8) Heat treatment after forming or welding is neither required nor prohibited. However, if heat treatment is applied, the solution annealing treatment shall consist of heating to a minimum temperature of 2,025°F and then quenching in water or rapidly cooling by other means.
- (9) These values apply to thickness less than $\frac{3}{16}$ in.
- (10) These values apply to thickness from $\frac{3}{16}$ in. up to and including $\frac{3}{4}$ in.
- (11) These values apply to thickness more than $\frac{3}{4}$ in.
- (12) All filler metal, including consumable insert material, shall comply with the requirements of Section IX of the ASME Boiler and Pressure Vessel Code.
- (13) These values ($E=1.00$) apply only to Class WX or WU fittings (all welds radiographed or ultrasonically examined).
- (14) This alloy is subject to severe loss of impact strength at room temperature after exposure in the range of 1,000°F to 1,400°F.
- (15) The minimum tensile strength of reduced tension specimens in accordance with QW-462.1 of Section IX shall not be less than 110,000 psi.
- (16) These values apply to material with a thickness of greater than 4 in. prior to machining or fabricating.
- (17) These values apply to material with a maximum thickness of 4 in. prior to machining or fabricating.
- (18) For service at 1,200°F or higher, the deposited weld metal shall be of the same nominal chemistry as the base metal.
- (19) Heat treatment after fabrication and forming is neither required nor prohibited. If heat treatment is performed, the material shall be heated for a sufficient time in the range of 2,010°F to 2,100°F followed by quenching in water or rapidly cooled by another means.
- (20) Welding electrodes or filler metal used for welding UNS N08926 shall conform to SFA-5.11 ENiCrMo-3 or ENiCrMo-4, or SFA-5.14 ERNiCrMo-3 or ERNiCrMo-4.
- (21) These values apply to thicknesses $\frac{3}{16}$ in. or less.
- (22) These values apply to thicknesses greater than $\frac{3}{16}$ in.
- (16) (23) The values apply to seamless pipe and tubing with outside diameter 5 in. and under.

(16)

Table A-5 Cast Iron

Spec. No.	Class	Notes	Specified Minimum Tensile, ksi	Specified Minimum Yield, ksi	E or F
Gray Cast Iron					
A48	20	(1)(2)(3)(4)	20
	25	(1)(2)(3)(4)	25
	30	(1)(2)(3)(4)	30
	35	(1)(2)(3)(4)	35
	40	(1)(2)(3)(4)	40
	45	(1)(2)(3)(4)	45
	50	(1)(2)(3)(4)	50
	55	(1)(2)(3)(4)	55
A126	60	(1)(2)(3)(4)	60
	A	(2)(3)(4)(7)	21
	B	(2)(3)(4)(7)	31
A278	C	(2)(3)(4)(7)	41
	20	(2)(4)(5)	20
	25	(2)(4)(5)	25
	30	(2)(4)(5)	30
	35	(2)(4)(5)	35
	40	(2)(4)(5)	40
	45	(2)(4)(5)	45
	50	(2)(4)(5)	50
A395	55	(2)(4)(5)	55
	60	(2)(4)(5)	60
Ductile Cast Iron					
A395	60-40-18	(6)(8)	60	40	0.80
	65-45-15	(6)(8)	65	45	0.80
A536	60-42-10	(1)(8)	60	42	0.80
	70-50-05	(1)(8)	70	50	0.80

GENERAL NOTES:

- The tabulated specifications are ANSI/ASTM or ASTM. For ASME Boiler and Pressure Vessel Code applications, see related specifications in Section II of the ASME Code.
- The stress values in this Table may be interpolated to determine values for intermediate temperatures.
- Cast iron components shall not be welded during fabrication or assembly as part of the piping system.
- Tensile strengths and allowable stresses shown in "ksi" are "thousands of pounds per square inch."
- The materials listed in this Table shall not be used at design temperatures above those for which allowable stress values are given.
- The tabulated stress values for ductile cast iron materials are $S \times F$ (material quality factor). Material quality factors are not applicable to other types of cast iron.
- Pressure-temperature ratings of piping components, as published in standards referenced in this Code, may be used for components meeting the requirements of those standards. The allowable stress values given in this Table are for use in designing piping components which are not manufactured in accordance with referenced standards.
- See para. 124.1.2 for lower temperature limits.

Table A-5 Cast Iron

(16)

Maximum Allowable Stress Values in Tension, ksi, for Metal Temperature, °F, Not Exceeding						
400	450	500	600	650	Class	Spec. No.
Gray Cast Iron						
2.0	20	A48
2.5	25	
3.0	30	
3.5	35	
4.0	40	
4.5	45	
5.0	50	
5.5	55	
6.0	60	
2.1	A	A126
3.1	B	
4.1	C	
2.0	2.0	20	A278
2.5	2.5	25	
3.0	3.0	30	
3.5	3.5	35	
4.0	4.0	40	
4.5	4.5	45	
5.0	5.0	50	
5.5	5.5	55	
6.0	6.0	60	
Ductile Cast Iron						
9.6	9.6	9.6	9.6	8.5	60-40-18	A395
10.4	10.4	65-45-15	
9.6	9.6	9.6	9.0	8.5	60-42-10	A536
11.2	11.2	11.2	10.5	10.0	70-50-05	

NOTES:

- (1) THIS MATERIAL IS NOT ACCEPTABLE FOR BOILER EXTERNAL PIPING — SEE FIG. 100.1.2(A.1), FIG. 100.1.2(A.2), FIG. 100.1.2(B.1), FIG. 100.1.2(B.2), AND FIG. 100.1.2(B.3).
- (2) Material quality factors are not applicable to these materials.
- (3) For saturated steam at 250 psi (406°F), the stress values given at 400°F may be used.
- (4) For limitations on the use of this material, see para. 124.4.
- (5) This material shall not be used where the design pressure exceeds 250 psig [1 725 kPa (gage)] or where the design temperature exceeds 450°F (230°C).
- (6) This material shall not be used for boiler external piping where the design pressure exceeds 350 psig [2 415 kPa (gage)] or where the design temperature exceeds 450°F (230°C).
- (7) Piping components conforming to either ASME B16.1 or ASME B16.4 may be used for boiler external piping, subject to all the requirements of the particular standard.
- (8) For limitations on the use of this material, see para. 124.6.

Table A-6 Copper and Copper Alloys

Spec. No.	UNS Alloy No.	Temper or Condition	Size or Thickness, in.	P-No.	Notes	Specified Minimum Tensile, ksi	Specified Minimum Yield, ksi	E or F
Seamless Pipe and Tube								
B42	C10200, C12000, C12200	Annealed	...	31	(2)	30	9	1.00
	C10200, C12000, C12200	Drawn	2 & under	31	(2)(4)	45	40	1.00
	C10200, C12000, C12200	Drawn	Over 2 to 12	31	(2)(4)	36	30	1.00
B43	C23000	Annealed	...	31	(2)	40	12	1.00
	C23000	Drawn	...	31	(2)(4)	40	18	1.00
B68	C10200, C12000, C12200	Annealed	...	31	(1)	30	9	1.00
B75	C10200, C12000, C12200	Annealed	...	31	(2)	30	9	1.00
	C10200, C12000, C12200	Light drawn	...	31	(2)(4)	36	30	1.00
	C10200, C12000, C12200	Hard drawn	...	31	(2)(4)	45	40	1.00
B88	C10200, C12000, C12200	Annealed	...	31	(1)	30	9	1.00
	C10200, C12000, C12200	Drawn	...	31	(1)(4)	36	30	1.00
B111	C10200, C12000	Light drawn	...	31	(1)(3)	36	30	1.00
	C10200, C12000	Hard drawn	...	31	(1)(3)	45	40	1.00
	C12200, C14200	Light drawn	...	31	(1)(3)	36	30	1.00
	C12200, C14200	Hard drawn	...	31	(1)(3)	45	40	1.00
B111	C23000	Annealed	...	32	(1)	40	12	1.00
	C28000	Annealed	...	32	(2)	50	20	1.00
	C44300, C44400, C44500	Annealed	...	32	(2)	45	15	1.00
	C60800	Annealed	...	35	(1)	50	19	1.00
B111	C68700	Annealed	...	32	(1)	50	18	1.00
	C70400	Annealed	...	34	(1)	38	12	1.00
	C70400	Light drawn	...	34	(1)(4)	40	30	1.00
B111	C70600	Annealed	...	34	(2)	40	15	1.00
	C71000	Annealed	...	34	(2)	45	16	1.00
	C71500	Annealed	...	34	(2)	52	18	1.00
B280	C12200	Annealed	...	31	(1)	30	9	1.00
	C12200	Drawn	...	31	(1)(4)	36	30	1.00
B302	C12000, C12200	Drawn	...	31	(1)(3)	36	30	1.00
B315	C61300, C61400	Annealed	...	35	(1)	65	28	1.00
B466	C70600	Annealed	...	34	(1)	38	13	1.00
	C71500	Annealed	...	34	(1)	52	18	1.00
Welded Pipe and Tube								
B467	C70600	Annealed	4½ & under	34	(1)	40	15	0.85
	C70600	Annealed	Over 4½	34	(1)	38	13	0.85
	C71500	Annealed	4½ & under	34	(1)	50	20	0.85
	C71500	Annealed	Over 4½	34	(1)	45	15	0.85
B608	C61300, C61400	Annealed	...	35	(1)(6)	70	30	0.80
Plate								
B171	C70600	Annealed	2½ & under	34	(1)	40	15	1.00
	C70600	Hot rolled	2½ & under	34	(1)	40	15	1.00
	C71500	Annealed	2½ & under	34	(1)	50	20	1.00
	C71500	Annealed	Over 2½ to 5	34	(1)	45	18	1.00

Table A-6 Copper and Copper Alloys

Maximum Allowable Stress Values in Tension, ksi, for Metal Temperature, °F, Not Exceeding																UNS Alloy No.	Spec. No.
100	150	200	250	300	350	400	450	500	550	600	650	700	750	800			
Seamless Pipe and Tube																	
6.0	5.1	4.9	4.8	4.7	4.0	3.0	C10200, C12000, C12200	B42
12.9	12.9	12.9	12.9	12.5	11.8	4.3	C10200, C12000, C12200	
10.3	10.3	10.3	10.3	10.0	9.7	9.4	C10200, C12000, C12200	
8.0	8.0	8.0	8.0	8.0	7.0	5.0	2.0	C23000	B43
8.0	8.0	8.0	8.0	8.0	7.0	5.0	2.0	C23000	
6.0	5.1	4.9	4.8	4.7	4.0	3.0	C10200, C12000, C12200	B68
6.0	5.1	4.9	4.8	4.7	4.0	3.0	C10200, C12000, C12200	B75
10.3	10.3	10.3	10.3	10.0	9.7	9.4	C10200, C12000, C12200	
12.9	12.9	12.9	12.9	12.5	11.8	4.3	C10200, C12000, C12200	
6.0	5.1	4.9	4.8	4.7	4.0	3.0	C10200, C12000, C12200	B88
10.3	10.3	10.3	10.3	10.0	9.7	9.4	C10200, C12000, C12200	
10.3	10.3	10.3	10.3	10.0	9.7	9.4	C10200, C12000	B111
12.9	12.9	12.9	12.9	12.5	11.8	4.3	C10200, C12000	
10.3	10.3	10.3	10.3	10.0	9.7	9.4	C12200, C14200	
12.9	12.9	12.9	12.9	12.5	11.8	4.3	C12200, C14200	
8.0	8.0	8.0	8.0	8.0	7.0	5.0	2.0	C23000	B111
13.3	13.3	13.3	13.3	13.3	10.8	5.3	C28000	
10.0	10.0	10.0	10.0	10.0	9.8	3.5	2.0	C44300, C44400, C44500	
12.7	12.2	12.2	12.2	12.0	10.0	6.0	4.0	2.0	C60800	
12.0	11.9	11.8	11.7	11.7	6.5	3.3	1.8	C68700	B111
8.0	8.0	C70400	
11.4	11.4	C70400	
10.0	9.7	9.5	9.3	9.0	8.8	8.7	8.5	8.0	7.0	6.0	C70600	B111
10.7	10.6	10.5	10.4	10.2	10.1	9.9	9.6	9.3	8.9	8.4	7.7	7.0	C71000	
12.0	11.6	11.3	11.0	10.8	10.5	10.3	10.1	9.9	9.8	9.6	9.5	9.4	C71500	
6.0	5.1	4.9	4.8	4.7	4.0	3.0	C12200	B280
10.3	10.3	10.3	10.3	10.0	9.7	9.4	C12200	
10.3	10.3	10.3	10.3	10.0	9.7	9.4	C12000, C12200	B302
18.6	18.6	18.5	18.3	18.2	18.1	17.9	17.5	17.0	C61300, C61400	B315
8.7	8.4	8.2	8.0	7.8	7.7	7.5	7.4	7.3	7.0	6.0	C70600	B466
12.0	11.6	11.3	11.0	10.8	10.5	10.3	10.1	9.9	9.8	9.6	9.5	9.4	C71500	
Welded Pipe and Tube																	
8.5	8.3	8.1	7.9	7.7	7.5	7.4	7.2	6.3	5.7	4.3	C70600	B467
7.4	7.2	7.0	6.8	6.7	6.5	6.4	6.3	6.2	5.7	4.3	C70600	
11.3	10.9	10.7	10.4	10.2	10.0	9.7	9.6	9.4	9.2	9.1	C71500	
8.5	8.2	8.0	7.8	7.6	7.5	7.3	7.2	7.0	6.9	6.8	C71500	
16.0	15.9	15.8	15.7	15.6	15.5	15.4	15.1	14.6	C61300, C61400	B608
Plate																	
10.0	9.7	9.5	9.3	9.0	8.8	8.7	8.5	8.0	7.0	6.0	C70600	B171
10.0	9.7	9.5	9.3	9.0	8.8	8.7	8.5	8.0	7.0	6.0	C70600	
13.3	12.9	12.6	12.3	12.0	11.7	11.5	11.2	11.0	10.8	10.7	10.6	10.4	C71500	
12.0	11.6	11.3	11.0	10.8	10.5	10.3	10.1	9.9	9.8	9.6	9.5	9.4	C71500	

Table A-6 Copper and Copper Alloys (Cont'd)

Spec. No.	UNS Alloy No.	Temper or Condition	Size or Thickness, in.	P-No.	Notes	Specified Minimum Tensile, ksi	Specified Minimum Yield, ksi	<i>E</i> or <i>F</i>
Rod								
B16	C36000	Annealed	1 & under	...	(2)(3)(7)(8)	48	20	1.00
	C36000	Annealed	Over 1 to 2	...	(2)(3)(7)(8)	44	18	1.00
	C36000	Annealed	Over 2	...	(2)(3)(7)(8)	40	15	1.00
B151	C71500	Annealed	Over 1	34	(1)	45	18	1.00
B453	C35300	Annealed	Under 1/2	...	(2)(3)(7)(8)	46	16	1.00
	C35300	Annealed	1/2 to 1	...	(2)(3)(7)(8)	44	15	1.00
	C35300	Annealed	Over 1	...	(2)(3)(7)(8)	40	15	1.00
Bar								
B16	C36000	Annealed	1 & under	...	(2)(3)(7)(8)	44	18	1.00
	C36000	Annealed	Over 1	...	(2)(3)(7)(8)	40	15	1.00
Die Forgings (Hot Pressed)								
B283	C37700	As forged	1 1/2 & under	...	(1)(3)	50	18	1.00
	C37700	As forged	Over 1 1/2	...	(1)(3)	46	15	1.00
Castings								
B61	C92200	As cast	34	16	0.80
B62	C83600	As cast	30	14	0.80
B148	C95200	As cast	...	35	(1)	65	25	0.80
	C95400	As cast	...	35	(1)(5)	75	30	0.80
B584	C92200	As cast	34	16	0.80
	C93700	As cast	(3)	30	12	0.80
	C97600	As cast	(3)	40	17	0.80

GENERAL NOTES:

- The tabulated specifications are ANSI/ASTM or ASTM. For ASME Boiler and Pressure Vessel Code applications, see related specifications in Section II of the ASME Code.
- The stress values in this Table may be interpolated to determine values for intermediate temperatures.
- The P-Numbers listed in this Table are identical to those adopted by the ASME Boiler and Pressure Vessel Code. Qualification of welding procedures, welders, and welding operators is required and shall comply with the ASME Boiler and Pressure Vessel Code, Section IX, except as modified by para. 127.5.
- Tensile strengths and allowable stresses shown in "ksi" are "thousands of pounds per square inch."
- The materials listed in this Table shall not be used at design temperatures above those for which allowable stress values are given. However, for saturated steam at 250 psi (406°F), the allowable stress values given for 400°F may be used.
- The tabulated stress values are $S \times E$ (weld joint efficiency factor) or $S \times F$ (material quality factor), as applicable. Weld joint efficiency factors are shown in Table 102.4.3.
- Pressure-temperature ratings of piping components, as published in standards referenced in this Code, may be used for components meeting the requirements of those standards. The allowable stress values given in this Table are for use in designing piping components that are not manufactured in accordance with referenced standards.
- For limitations on the use of copper and copper alloys for flammable liquids and gases, refer to paras. 122.7, 122.8, and 124.7.
- The γ coefficient equals 0.4 [see Table 104.1.2(A)].
- The tabulated stress values that are shown in italics are at temperatures in the range where creep and stress rupture strength govern the selection of stresses.
- See para. 124.1.2 for lower temperature limits.

Table A-6 Copper and Copper Alloys (Cont'd)

Maximum Allowable Stress Values in Tension, ksi, for Metal Temperature, °F, Not Exceeding															UNS Alloy No.	Spec. No.
100	150	200	250	300	350	400	450	500	550	600	650	700	750	800		
Rod																
13.3	12.6	12.0	11.5	11.1	10.7	5.3	2.0	C36000	B16
12.0	11.3	10.8	10.4	10.0	9.7	5.3	2.0	C36000	
10.0	9.4	9.0	8.7	8.3	8.1	5.3	2.0	C36000	
12.0	11.6	11.3	11.0	10.8	10.5	10.3	10.1	9.9	9.8	9.6	9.5	9.4	C71500	B151
10.7	10.1	9.6	9.2	8.9	8.6	5.3	2.0	C35300	B453
10.0	9.4	9.0	8.7	8.3	8.1	5.3	2.0	C35300	
10.0	9.4	9.0	8.7	8.3	8.1	5.3	2.0	C35300	
Bar																
12.0	11.3	10.8	10.4	10.0	9.7	5.3	2.0	C36000	B16
10.0	9.4	9.0	8.7	8.3	8.1	5.3	2.0	C36000	
Die Forgings (Hot Pressed)																
12.0	11.3	10.8	C37700	B283
10.0	9.4	9.0	C37700	
Castings																
7.8	7.8	7.8	7.8	7.8	7.8	6.6	6.2	5.8	4.0	C92200	B61
6.9	6.9	6.9	6.9	6.6	6.5	5.5	5.4	C83600	B62
13.4	12.6	12.2	11.8	11.6	11.4	11.4	11.4	11.4	9.4	5.9	C95200	B148
16.0	15.2	15.0	14.8	14.8	14.8	14.8	12.8	11.1	8.8	6.8	C95400	
7.8	7.8	7.8	7.8	7.8	7.8	6.6	6.2	5.8	4.0	C92200	B584
6.4	5.9	5.5	5.3	5.3	5.2	5.1	C93700	
6.0	5.8	5.6	5.5	5.4	C97600	

NOTES:

- (1) THIS MATERIAL IS NOT ACCEPTABLE FOR USE ON BOILER EXTERNAL PIPING — SEE FIG. 100.1.2(A.1), FIG. 100.1.2(A.2), FIG. 100.1.2(B.1), FIG. 100.1.2(B.2), AND FIG. 100.1.2(B.3).
- (2) This material may be used for Boiler External Piping provided that the nominal size does not exceed 3 in. and the design temperature does not exceed 406°F. This material shall not be used for blowoff or blowdown piping except as permitted in para. 122.1.4. Where threaded brass or copper pipe is used for feedwater piping, it shall have a wall thickness not less than that required for schedule 80 steel pipe of the same nominal size.
- (3) Welding or brazing of this material is not permitted.
- (4) When this material is used for welded or brazed construction, the allowable stress values used shall not exceed those given for the same material in the annealed condition.
- (5) Castings that are welded or repair welded shall be heat treated at 1,150°F–1,200°F, followed by moving-air cooling. The required time at temperature is based on the cross-section thicknesses as follows:
 - (a) 1½ hr for the first inch or fraction thereof
 - (b) ½ hr for each additional inch or fraction thereof
- (6) Welds must be made by an electric fusion welding process involving the addition of filler metal.
- (7) Material conforming to ASTM B16 alloy C36000 shall not be used in primary pressure relief valve applications.
- (8) Materials shall be tested to determine the presence of residual stresses that might result in failure of individual parts due to stress corrosion cracking. Tests shall be conducted in accordance with ASTM B154 or ASTM B858. The test frequency shall be as specified in ASTM B249.

(16)

Table A-7 Aluminum and Aluminum Alloys

Spec. No.	UNS Alloy No.	Temper	Size or Thickness, in.	P-No.	Notes	Specified Minimum Tensile, ksi	Specified Minimum Yield, ksi	E or F
Drawn Seamless Tube								
B210	A93003	O	0.010 to 0.500	21	(1)	14	5	1.00
	A93003	H14	0.010 to 0.500	21	(1)(3)	20	17	1.00
	Alclad A93003	O	0.010 to 0.500	21	(1)(4)	13	4.5	1.00
	Alclad A93003	H14	0.010 to 0.500	21	(1)(3)(4)	19	16	1.00
B210	A95050	O	0.018 to 0.500	21	(1)	18	6	1.00
	Alclad A95050	O	0.018 to 0.500	21	(1)(13)(23)	17	...	1.00
	A96061	T4	0.025 to 0.500	23	(1)(6)	30	16	1.00
	A96061	T6	0.025 to 0.500	23	(1)(6)	42	35	1.00
	A96061	T4, T6 welded	0.025 to 0.500	23	(1)(7)	24	...	1.00
Seamless Pipe and Seamless Extruded Tube								
B241	A93003	O	All	21	(1)	14	5	1.00
	A93003	H18	Less than 1.000	21	(1)(3)	27	24	1.00
B241	A93003	H112	Note (20)	21	(1)(3)(20)	14	5	1.00
	Alclad A93003	O	All	21	(1)(4)	13	4.5	1.00
	Alclad A93003	H112	All	21	(1)(3)(4)	13	4.5	1.00
B241	A95083	O	All	25	(1)(8)	39	16	1.00
	A95083	H112	All	25	(1)(3)(8)	39	16	1.00
	A95454	O	Up thru 5.000	22	(1)	31	12	1.00
	A95454	H112	Up thru 5.000	22	(1)	31	12	1.00
B241	A96061	T4	All	23	(1)(6)(9)	26	16	1.00
	A96061	T6	Pipe < NPS 1	23	(1)(2)(5)	42	35	1.00
	A96061	T6	Note (24)	23	(1)(6)(9)(24)	38	35	1.00
	A96061	T4, T6 welded	All	23	(1)(7)(9)	24	...	1.00
	A96063	T6	Note (10)	23	(1)(6)(10)	30	25	1.00
	A96063	T5, T6 welded	Note (10)	23	(1)(7)(10)	17	10	1.00
Drawn Seamless Condenser and Heat Exchanger Tube								
B234	A93003	H14	0.010 to 0.200	21	(1)(2)	20	17	1.00
	Alclad A93003	H14	0.010 to 0.200	21	(1)(2)(4)	19	16	1.00
	A95454	H34	0.010 to 0.200	22	(1)(2)	39	29	1.00
B234	A96061	T4	0.025 to 0.200	23	(1)(6)	30	16	1.00
	A96061	T6	0.025 to 0.200	23	(1)(6)	42	35	1.00
	A96061	T4, T6 welded	0.025 to 0.200	23	(1)(7)	24	...	1.00
Arc-Welded Round Tube								
B547	A93003	O	0.125 to 0.500	21	(1)(15)	14	5	1.00
	A93003	O	0.125 to 0.500	21	(1)(16)	14	5	0.85
	A93003	H112	0.250 to 0.400	21	(1)(14)(15)	17	10	1.00
	A93003	H112	0.250 to 0.400	21	(1)(14)(16)	17	10	0.85
B547	Alclad A93003	O	0.125 to 0.499	21	(1)(4)(15)	13	4.5	1.00
	Alclad A93003	O	0.125 to 0.499	21	(1)(4)(16)	13	4.5	0.85
	Alclad A93003	H112	0.250 to 0.499	21	(1)(4)(14)(15)	16	9	1.00
	Alclad A93003	H112	0.250 to 0.499	21	(1)(4)(14)(16)	16	9	0.85

Table A-7 Aluminum and Aluminum Alloys

(16)

Maximum Allowable Stress Values in Tension, ksi, for Metal Temperature, °F, Not Exceeding								Spec. No.
100	150	200	250	300	350	400	UNS Alloy No.	
Drawn Seamless Tube								
3.4	3.4	3.4	3.0	2.4	1.8	1.4	A93003	B210
5.7	5.7	5.7	4.9	4.3	3.0	2.4	A93003	
3.0	3.0	3.0	2.7	2.2	1.6	1.3	Alclad A93003	
5.1	5.1	5.1	4.5	3.9	2.7	2.1	Alclad A93003	
4.0	4.0	4.0	4.0	4.0	2.8	1.4	A95050	B210
3.3	3.3	3.3	3.3	3.3	2.8	1.4	Alclad A95050	
8.6	8.6	8.6	8.5	6.9	6.3	4.5	A96061	
12.0	12.0	12.0	11.7	8.4	6.3	4.5	A96061	
6.9	6.9	6.9	6.8	5.5	4.6	3.5	A96061	
Seamless Pipe and Seamless Extruded Tube								
3.4	3.4	3.4	3.0	2.4	1.8	1.4	A93003	B241
7.8	7.8	7.7	6.3	5.4	3.5	2.5	A93003	
3.4	3.4	3.4	3.0	2.4	1.8	1.4	A93003	B241
3.0	3.0	3.0	2.7	2.2	1.6	1.2	Alclad A93003	
3.0	3.0	3.0	2.7	2.2	1.6	1.2	Alclad A93003	
10.7	10.7	A95083	B241
10.7	10.7	A95083	
8.0	8.0	8.0	7.5	5.5	4.1	3.0	A95454	
8.0	8.0	8.0	7.5	5.5	4.1	3.0	A95454	
7.4	7.4	7.4	7.4	6.0	5.8	4.5	A96061	B241
12.0	12.0	12.0	11.7	8.4	6.3	4.5	A96061	
10.9	10.9	10.9	10.6	7.9	6.3	4.5	A96061	
6.9	6.9	6.9	6.8	5.5	4.6	3.5	A96061	
8.6	8.6	8.6	6.8	5.0	3.4	2.0	A96063	
4.3	4.3	4.3	4.2	3.9	3.0	2.0	A96063	
Drawn Seamless Condenser and Heat Exchanger Tube								
5.7	5.7	5.7	4.9	4.3	3.0	2.4	A93003	B234
5.1	5.1	5.1	4.5	3.9	2.7	2.1	Alclad A93003	
11.1	11.1	11.1	7.5	5.5	4.1	3.0	A95454	
8.6	8.6	8.6	8.5	6.9	6.3	4.5	A96061	B234
12.0	12.0	12.0	11.7	8.4	6.3	4.5	A96061	
6.9	6.9	6.9	6.8	5.5	4.6	3.5	A96061	
Arc-Welded Round Tube								
3.4	3.4	3.4	3.0	2.4	1.8	1.4	A93003	B547
2.9	2.9	2.9	2.6	2.0	1.5	1.2	A93003	
4.9	4.9	4.9	4.0	3.6	3.0	2.4	A93003	
4.2	4.2	4.2	3.4	3.1	2.6	2.0	A93003	
3.0	3.0	3.0	2.7	2.2	1.6	1.3	Alclad A93003	B547
2.6	2.6	2.6	2.3	1.9	1.4	1.1	Alclad A93003	
4.6	4.6	4.6	2.7	2.2	1.6	1.3	Alclad A93003	
3.9	3.9	3.9	2.3	1.9	1.4	1.1	Alclad A93003	

(16)

Table A-7 Aluminum and Aluminum Alloys (Cont'd)

Spec. No.	UNS Alloy No.	Temper	Size or Thickness, in.	P-No.	Notes	Specified Minimum Tensile, ksi	Specified Minimum Yield, ksi	E or F
Arc-Welded Round Tube (Cont'd)								
B547	A95083	O	0.125 to 0.500	25	(1)(8)(15)	40	18	1.00
	A95083	O	0.125 to 0.500	25	(1)(8)(16)	40	18	0.85
B547	A95454	O	0.125 to 0.500	22	(1)(15)	31	12	1.00
	A95454	O	0.125 to 0.500	22	(1)(16)	31	12	0.85
	A95454	H112	0.250 to 0.499	22	(1)(14)(15)	32	18	1.00
	A95454	H112	0.250 to 0.499	22	(1)(14)(16)	32	18	0.85
B547	A96061	T4	0.125 to 0.249	23	(1)(7)(15)(17)	30	16	1.00
	A96061	T4	0.125 to 0.249	23	(1)(7)(16)(17)	30	16	0.85
	A96061	T451	0.250 to 0.500	23	(1)(7)(15)(17)	30	16	1.00
	A96061	T451	0.250 to 0.500	23	(1)(7)(16)(17)	30	16	0.85
B547	A96061	T6	0.125 to 0.249	23	(1)(7)(15)(17)	42	35	1.00
	A96061	T6	0.125 to 0.249	23	(1)(7)(16)(17)	42	35	0.85
	A96061	T651	0.250 to 0.500	23	(1)(7)(15)(17)	42	35	1.00
	A96061	T651	0.250 to 0.500	23	(1)(7)(16)(17)	42	35	0.85
B547	A96061	T4	0.125 to 0.249	23	(1)(7)(15)(25)	30	16	1.00
	A96061	T4	0.125 to 0.249	23	(1)(7)(16)(25)	30	16	0.85
	A96061	T451	0.250 to 0.500	23	(1)(7)(15)(25)	30	16	1.00
	A96061	T451	0.250 to 0.500	23	(1)(7)(16)(25)	30	16	0.85
B547	A96061	T6	0.125 to 0.249	23	(1)(7)(15)(25)	42	35	1.00
	A96061	T6	0.125 to 0.249	23	(1)(7)(16)(25)	42	35	0.85
	A96061	T651	0.250 to 0.500	23	(1)(7)(15)(25)	42	35	1.00
	A96061	T651	0.250 to 0.500	23	(1)(7)(16)(25)	42	35	0.85
Sheet and Plate								
B209	A93003	O	0.051 to 3.000	21	(1)	14	5	1.00
	A93003	H112	0.250 to 0.499	21	(1)(3)	17	10	1.00
	A93003	H112	0.500 to 2.000	21	(1)(3)	15	6	1.00
B209	Alclad A93003	O	0.051 to 0.499	21	(1)(4)	13	4.5	1.00
	Alclad A93003	O	0.500 to 3.000	21	(1)(18)	14	5	1.00
	Alclad A93003	H112	0.250 to 0.499	21	(1)(3)(4)	16	9	1.00
	Alclad A93003	H112	0.500 to 2.000	21	(1)(3)(19)	15	6	1.00
B209	A95083	O	0.051 to 1.500	25	(1)(8)	40	18	1.00
	A95454	O	0.051 to 3.000	22	(1)	31	12	1.00
	A95454	H112	0.250 to 0.499	22	(1)(3)	32	18	1.00
	A95454	H112	0.500 to 3.000	22	(1)(3)	31	12	1.00
B209	A96061	T4	0.006 to 0.249	23	(1)(6)(9)	30	16	1.00
	A96061	T451	0.250 to 3.000	23	(1)(6)(9)	30	16	1.00
	A96061	T4 welded	0.006 to 0.249	23	(1)(7)(9)	24	...	1.00
	A96061	T451 welded	0.250 to 3.000	23	(1)(7)(9)	24	...	1.00
B209	A96061	T6	0.051 to 0.249	23	(1)(6)(9)	42	35	1.00
	A96061	T651	0.250 to 4.000	23	(1)(6)(9)	42	35	1.00
	A96061	T651	4.001 to 6.000	23	(1)(6)(9)	40	35	1.00
	A96061	T6 welded	0.051 to 0.249	23	(1)(7)(9)	24	...	1.00
	A96061	T651 welded	0.250 to 6.000	23	(1)(7)(9)	24	...	1.00

Table A-7 Aluminum and Aluminum Alloys (Cont'd)

(16)

Maximum Allowable Stress Values in Tension, ksi, for Metal Temperature, °F, Not Exceeding								Spec. No.
100	150	200	250	300	350	400	UNS Alloy No.	
Arc-Welded Round Tube (Cont'd)								
11.4	11.4	A95083	B547
9.7	9.7	A95083	
8.0	8.0	8.0	7.5	5.5	4.1	3.0	A95454	B547
6.8	6.8	6.8	6.4	4.7	3.5	2.6	A95454	
9.1	9.1	9.1	7.5	5.5	4.1	3.0	A95454	
7.8	7.8	7.8	6.4	4.7	3.5	2.6	A95454	
8.6	8.6	8.6	8.5	6.9	6.3	4.5	A96061	B547
7.3	7.3	7.3	7.2	5.9	5.4	3.8	A96061	
8.6	8.6	8.6	8.5	6.9	6.3	4.5	A96061	
7.3	7.3	7.3	7.2	5.9	5.4	3.8	A96061	
12.0	12.0	12.0	11.7	8.4	6.3	4.5	A96061	B547
10.2	10.2	10.2	9.9	7.1	5.4	3.8	A96061	
12.0	12.0	12.0	11.7	8.4	6.3	4.5	A96061	
10.2	10.2	10.2	9.9	7.1	5.4	3.8	A96061	
6.9	6.9	6.9	6.9	5.5	4.6	3.5	A96061	B547
5.9	5.9	5.9	5.9	4.7	3.9	3.0	A96061	
6.9	6.9	6.9	6.9	5.5	4.6	3.5	A96061	
5.9	5.9	5.9	5.9	4.7	3.9	3.0	A96061	
6.9	6.9	6.9	6.9	5.5	4.6	3.5	A96061	B547
5.9	5.9	5.9	5.9	4.7	3.9	3.0	A96061	
6.9	6.9	6.9	6.9	5.5	4.6	3.5	A96061	
5.9	5.9	5.9	5.9	4.7	3.9	3.0	A96061	
Sheet and Plate								
3.4	3.4	3.4	3.0	2.4	1.8	1.4	A93003	B209
4.9	4.9	4.9	4.0	3.6	3.0	2.4	A93003	
3.8	3.8	3.7	3.2	2.4	1.8	1.4	A93003	
3.0	3.0	3.0	2.7	2.2	1.6	1.3	Alclad A93003	B209
3.0	3.0	3.0	2.7	2.2	1.6	1.3	Alclad A93003	
4.3	4.3	4.3	3.8	3.3	2.7	2.1	Alclad A93003	
3.9	3.9	3.9	3.0	2.2	1.6	1.3	Alclad A93003	
11.4	11.4	A95083	B209
8.0	8.0	8.0	7.5	5.5	4.1	3.0	A95454	
9.1	9.1	9.1	7.5	5.5	4.1	3.0	A95454	
8.0	8.0	8.0	7.5	5.5	4.1	3.0	A95454	
8.6	8.6	8.6	8.5	6.9	6.3	4.5	A96061	B209
8.6	8.6	8.6	8.5	6.9	6.3	4.5	A96061	
6.9	6.9	6.9	6.8	5.5	4.6	3.5	A96061	
6.9	6.9	6.9	6.8	5.5	4.6	3.5	A96061	
12.0	12.0	12.0	11.7	8.4	6.3	4.5	A96061	B209
12.0	12.0	12.0	11.7	8.4	6.3	4.5	A96061	
11.4	11.4	11.4	11.1	8.2	6.3	4.4	A96061	
6.9	6.9	6.9	6.8	5.5	4.6	3.5	A96061	
6.9	6.9	6.9	6.8	5.5	4.6	3.5	A96061	

(16)

Table A-7 Aluminum and Aluminum Alloys (Cont'd)

Spec. No.	UNS Alloy No.	Temper	Size or Thickness, in.	P-No.	Notes	Specified Minimum Tensile, ksi	Specified Minimum Yield, ksi	E or F
Die and Hand Forgings								
B247	A93003	H112	Up thru 4.000	21	(1)(11)	14	5	1.00
	A93003	H112 welded	Up thru 4.000	21	(1)(7)(11)	14	5	1.00
B247	A95083	H111	Up thru 4.000	25	(1)(6)(8)	39	20	1.00
	A95083	H112	Up thru 4.000	25	(1)(6)(8)	39	16	1.00
	A95083	H111, H112 welded	Up thru 4.000	25	(1)(7)(8)	38	16	1.00
B247	A96061	T6	Up thru 4.000	23	(1)(6)(11)	38	35	1.00
	A96061	T6	Up thru 4.000	23	(1)(6)(12)	37	33	1.00
	A96061	T6	4.001 to 8.000	23	(1)(6)(12)	35	32	1.00
	A96061	T6 welded	Up thru 8.000	23	(1)(7)	24	...	1.00
Rods, Bars, and Shapes								
B221	A91060	O	All	21	(1)(21)(22)	8.5	2.5	1.00
	A91060	H112	All	21	(1)(3)(21)(22)	8.5	2.5	1.00
B221	A91100	O	All	21	(1)(21)(22)	11	3	1.00
	A91100	H112	All	21	(1)(3)(21)(22)	11	3	1.00
B221	A93003	O	All	21	(1)(21)(22)	14	5	1.00
	A93003	H112	All	21	(1)(3)(21)(22)	14	5	1.00
B221	A92024	T3	Up thru 0.249	...	(1)(2)(9)(21)(22)	57	42	1.00
	A92024	T3	0.250–0.749	...	(1)(2)(9)(21)(22)	60	44	1.00
	A92024	T3	0.750–1.499	...	(1)(2)(9)(21)(22)	65	46	1.00
	A92024	T3	1.500 and over	...	(1)(2)(9)(21)(22)	68	48	1.00
B221	A95083	O	Up thru 5.000	25	(1)(8)(21)(22)	39	16	1.00
	A95083	H111	Up thru 5.000	25	(1)(3)(8)(21)(22)	40	24	1.00
	A95083	H112	Up thru 5.000	25	(1)(3)(8)(21)(22)	39	16	1.00
B221	A95086	H112	Up thru 5.000	25	(1)(2)(8)(21)(22)	35	14	1.00
B221	A95154	O	All	22	(1)(8)(21)(22)	30	11	1.00
	A95154	H112	All	22	(1)(3)(8)(21)(22)	30	11	1.00
B221	A95454	O	Up thru 5.000	22	(1)(21)(22)	31	12	1.00
	A95454	H111	Up thru 5.000	22	(1)(3)(21)(22)	33	19	1.00
	A95454	H112	Up thru 5.000	22	(1)(3)(21)(22)	31	12	1.00
B221	A95456	O	Up thru 5.000	25	(1)(8)(21)(22)	41	19	1.00
	A95456	H111	Up thru 5.000	25	(1)(3)(8)(21)(22)	42	26	1.00
	A95456	H112	Up thru 5.000	25	(1)(3)(8)(21)(22)	41	19	1.00
B221	A96061	T4	All	23	(1)(2)(9)(21)(22)	26	16	1.00
	A96061	T6	All	23	(1)(2)(9)(21)(22)	38	35	1.00
	A96061	T4 welded	All	23	(1)(7)(9)(21)(22)	24	...	1.00
	A96061	T6 welded	All	23	(1)(7)(9)(21)(22)	24	...	1.00

Table A-7 Aluminum and Aluminum Alloys (Cont'd)

(16)

Maximum Allowable Stress Values in Tension, ksi, for Metal Temperature, °F, Not Exceeding								Spec. No.
100	150	200	250	300	350	400	UNS Alloy No.	
Die and Hand Forgings								
3.4	3.4	3.4	3.0	2.4	1.8	1.4	A93003	B247
3.4	3.4	3.4	3.0	2.4	1.8	1.4	A93003	
11.1	11.1	A95083	B247
10.7	10.7	A95083	
10.9	10.9	A95083	
10.9	10.9	10.9	10.6	7.9	6.3	4.5	A96061	B247
10.6	10.6	10.6	10.5	7.7	6.3	4.5	A96061	
10.0	10.0	10.0	9.9	7.4	6.1	4.5	A96061	
6.9	6.9	6.9	6.8	5.5	4.6	3.5	A96061	
Rods, Bars, and Shapes								
1.7	1.7	1.6	1.5	1.3	1.1	0.8	A91060	B221
1.7	1.7	1.6	1.5	1.3	1.1	0.8	A91060	
2.0	2.0	2.0	2.0	1.8	1.4	1.0	A91100	B221
2.0	2.0	2.0	2.0	1.8	1.4	1.0	A91100	
3.4	3.4	3.4	3.0	2.4	1.8	1.4	A93003	B221
3.4	3.4	3.4	3.0	2.4	1.8	1.4	A93003	
16.3	16.3	16.3	12.6	9.5	6.0	4.2	A92024	B221
17.1	17.1	17.1	13.2	10.0	6.3	4.4	A92024	
18.6	18.6	18.6	14.3	10.8	6.8	4.7	A92024	
19.4	19.4	19.4	15.0	11.3	7.1	5.0	A92024	
10.7	10.7	A95083	B221
11.4	11.4	A95083	
10.7	10.7	A95083	
9.3	9.3	A95086	B221
7.3	7.3	A95154	B221
7.3	7.3	A95154	
8.0	8.0	8.0	7.5	5.5	4.1	3.0	A95454	B221
9.4	9.4	9.4	7.5	5.5	4.1	3.0	A95454	
8.0	8.0	8.0	7.5	5.5	4.1	3.0	A95454	
11.7	11.7	A95456	B221
12.0	12.0	A95456	
11.7	11.7	A95456	
7.4	7.4	7.4	7.4	6.0	5.8	4.5	A96061	B221
10.9	10.9	10.9	10.6	7.9	6.3	4.5	A96061	
6.9	6.9	6.9	6.8	5.5	4.6	3.5	A96061	
6.9	6.9	6.9	6.8	5.5	4.6	3.5	A96061	

Table A-7 Aluminum and Aluminum Alloys (Cont'd)

Spec. No.	UNS Alloy No.	Temper	Size or Thickness, in.	P-No.	Notes	Specified Minimum Tensile, ksi	Specified Minimum Yield, ksi	<i>E</i> or <i>F</i>
Rods, Bars, and Shapes (Cont'd)								
B221	A96063	T1	Up thru 0.500	23	(1)(2)(21)(22)	17	9	1.00
	A96063	T1	0.501–1.000	23	(1)(2)(21)(22)	16	8	1.00
	A96063	T5	Up thru 0.500	23	(1)(2)(21)(22)	22	16	1.00
	A96063	T5	0.501–1.000	23	(1)(2)(21)(22)	21	15	1.00
	A96063	T6	Up thru 1.000	23	(1)(2)(21)(22)	30	25	1.00
	A96063	T5, T6 welded	Up thru 1.000	23	(1)(7)(21)(22)	17	10	1.00
Castings								
B26	A24430	F	(1)(2)	17	6	0.80
	A03560	T6	(1)(2)	30	20	0.80
	A03560	T71	(1)(2)	25	18	0.80

GENERAL NOTES:

- The tabulated specifications are ANSI/ASTM or ASTM. For ASME Boiler and Pressure Vessel Code applications, see related specifications in Section II of the ASME Code.
- The stress values in this Table may be interpolated to determine values for intermediate temperatures.
- The P-Numbers listed in this Table are identical to those adopted by the ASME Boiler and Pressure Vessel Code. Qualification of welding procedures, welders, and welding operators is required and shall comply with the ASME Boiler and Pressure Vessel Code, Section IX, except as modified by para. 127.5.
- Tensile strengths and allowable stresses shown in “ksi” are “thousands of pounds per square inch.”
- The materials listed in this Table shall not be used at design temperatures above those for which allowable stress values are given.
- The tabulated stress values are $S \times E$ (weld joint efficiency factor) or $S \times F$ (material quality factor), as applicable. Weld joint efficiency factors are shown in Table 102.4.3.
- Pressure–temperature ratings of piping components, as published in standards referenced in this Code, may be used for components meeting the requirements of those standards. The allowable stress values given in this Table are for use in designing piping components that are not manufactured in accordance with referenced standards.
- Aluminum and aluminum alloys shall not be used for flammable fluids within the boiler plant structure (see para. 122.7).
- The γ coefficient equals 0.4 [see Table 104.1.2(A)].
- The tabulated stress values that are shown in italics are at temperatures in the range where creep and stress rupture strength govern the selection of stresses.
- See para. 124.1.2 for lower temperature limits.

NOTES:

- THIS MATERIAL IS NOT ACCEPTABLE FOR USE ON BOILER EXTERNAL PIPING — SEE FIG. 100.1.2(A.1), FIG. 100.1.2(A.2), FIG. 100.1.2(B.1), FIG. 100.1.2(B.2), AND FIG. 100.1.2(B.3).
- These allowable stress values are not applicable when either welding or thermal cutting is employed.
- These allowable stress values are not applicable when either welding or thermal cutting is employed. In such cases, the corresponding stress values for the O temper shall be used.
- These allowable stress values are 90% of those for the corresponding core material.
- These allowable stress values apply only to seamless pipe smaller than NPS 1 that is extruded and then drawn.
- These allowable stress values are not applicable when either welding or thermal cutting is employed. In such cases, the corresponding stress values for the welded condition shall be used.

Table A-7 Aluminum and Aluminum Alloys (Cont'd)

Maximum Allowable Stress Values in Tension, ksi, for Metal Temperature, °F, Not Exceeding								Spec. No.
100	150	200	250	300	350	400	UNS Alloy No.	
								Rods, Bars, and Shapes (Cont'd)
4.9	4.9	4.9	4.2	4.2	3.4	2.0	A96063	B221
4.6	4.6	4.6	4.0	4.0	3.4	2.0	A96063	
6.3	6.3	6.3	5.1	4.6	3.4	2.0	A96063	
6.0	6.0	6.0	4.9	4.3	3.4	2.0	A96063	
8.6	8.6	8.6	6.8	5.0	3.4	2.0	A96063	
4.3	4.3	4.3	4.2	3.9	3.0	2.0	A96063	
								Castings
3.2	3.2	3.2	3.0	2.8	2.5	2.2	A24430	B26
6.9	6.9	6.9	5.0	A03560	
5.8	5.8	5.8	5.0	4.3	3.3	1.9	A03560	

NOTES (Cont'd):

- (7) The strength of a reduced-section tensile specimen is required to qualify welding procedures. Refer to the ASME Boiler and Pressure Vessel Code, Section IX, QW-150.
- (8) Refer to the ASME Boiler and Pressure Vessel Code, Section VIII, Division 1, Part UNF, NF-13(b) regarding stress corrosion.
- (9) For stress relieved tempers (T351, T3510, T3511, T451, T4510, T4511, T651, T6510, and T6511), stress values for the material in the basic temper shall be used.
- (10) These allowable stress values apply to all thicknesses and sizes of seamless pipe. They also apply to seamless extruded tube in thicknesses up to and including 1.000 in.
- (11) These allowable stress values are for die forgings.
- (12) These allowable stress values are for hand forgings.
- (13) For temperatures up to 300°F, these allowable stress values are 83% of those for the corresponding core material. At temperatures of 350°F and 400°F, these allowable stress values are 90% of those for the corresponding core material.
- (14) These allowable stress values are for the tempers listed in the welded condition and are identical to those for the O temper.
- (15) These allowable stress values are based on 100% radiography of the longitudinal weld in accordance with ASTM B547, para. 11.
- (16) These allowable stress values are based on spot radiography of the longitudinal weld in accordance with ASTM B547, para. 11.
- (16) (17) These allowable stress values are for the heat-treated tempers listed that are tempered after welding.
- (18) The tension test specimen from plate which is not less than 0.500 in. thick is machined from the core and does not include the cladding alloy. Therefore, the allowable stress values for thicknesses less than 0.500 in. shall be used.
- (19) The tension test specimen from plate which is not less than 0.500 in. thick is machined from the core and does not include the cladding alloy. Therefore, these allowable stress values are 90% of those for the core material of the same thickness.
- (20) The allowable stress values for seamless pipe in sizes NPS 1 and larger are as follows:
- | | |
|-------|---------|
| 100°F | 3.5 ksi |
| 150°F | 3.5 ksi |
| 200°F | 3.4 ksi |
- (21) Stress values in restricted shear, such as in dowel bolts or similar construction in which the shearing member is so restricted that the section under consideration would fail without reduction of area, shall be 0.80 times the values in this Table.
- (22) Stress values in bearing shall be 1.60 times the values in this Table.
- (23) ASTM B210 does not include this alloy/grade of material.
- (16) (24) These allowable stress values apply to all thicknesses and sizes of seamless tubing. They also apply to NPS 1 and larger seamless pipe.
- (16) (25) These allowable stress values are for the tempers listed in the welded condition.

Table A-8 Temperatures 1,200°F and Above

Spec. No.	Type or Grade	UNS Alloy No.	Temper	Nominal Composition	P-No.	Notes	Specified Minimum Tensile, ksi	Specified Minimum Yield, ksi
Seamless Pipe and Tube								
A213	TP304H	S30409	...	18Cr-8Ni	8	...	75	30
	...	S30815	...	21Cr-11Ni-N	8	(1)	87	45
	TP310H	S31009	...	25Cr-20Ni	8	(2)(4)	75	30
	TP316H	S31609	...	16Cr-12Ni-2Mo	8	...	75	30
	TP316L	S31603	...	16Cr-12Ni-2Mo	8	(1)	70	25
A213	TP321H	S32109	...	18Cr-10Ni-Ti	8	...	75	30
	TP347H	S34709	...	18Cr-10Ni-Cb	8	...	75	30
	TP348H	S34809	...	18Cr-10Ni-Cb	8	...	75	30
A312	TP304H	S30409	...	18Cr-8Ni	8	...	75	30
	...	S30815	...	21Cr-11Ni-N	8	(1)	87	45
	TP310H	S31009	...	25Cr-20Ni	8	(2)(4)	75	30
	TP316H	S31609	...	16Cr-12Ni-2Mo	8	...	75	30
A312	TP321H	S32109	...	18Cr-10Ni-Ti	8	...	75	30
	TP347H	S34709	...	18Cr-10Ni-Cb	8	...	75	30
	TP348H	S34809	...	18Cr-10Ni-Cb	8	...	75	30
A376	TP304H	S30409	...	18Cr-8Ni	8	...	75	30
	TP316H	S31609	...	16Cr-12Ni-2Mo	8	...	75	30
	TP321H	S32109	...	18Cr-10Ni-Ti	8	...	75	30
	TP347H	S34709	...	18Cr-10Ni-Cb	8	...	75	30
B163	...	N08800	Annealed	Ni-Cr-Fe	45	(1)	75	30
	...	N08810	Annealed	Ni-Cr-Fe	45	(1)	65	25
B167	...	N06617	Annealed	52Ni-22Cr-13Co-9Mo	43	...	95	35
B407	...	N08800	C.D./ann.	Ni-Cr-Fe	45	...	75	30
	...	N08810	Annealed	Ni-Cr-Fe	45	...	65	25
B622	...	R30556	Annealed	Ni-Fe-Cr-Co-Mo-W	45	(1)	100	45
Welded Pipe and Tube — Without Filler Metal								
A249	TP304H	S30409	...	18Cr-8Ni	8	...	75	35
	...	S30815	...	21Cr-11Ni-N	8	(1)	87	45
	TP310H	S31009	...	25Cr-20Ni	8	(1)(2)(4)	75	35
	TP316H	S31609	...	16Cr-12Ni-2Mo	8	...	75	35
A249	TP321H	S32109	...	18Cr-10Ni-Ti	8	...	75	35
	TP347H	S34709	...	18Cr-10Ni-Cb	8	...	75	35
	TP348H	S34809	...	18Cr-10Ni-Cb	8	...	75	35
A312	TP304H	S30409	...	18Cr-8Ni	8	...	75	30
	...	S30815	...	21Cr-11Ni-N	8	(1)	87	45
	TP310H	S31009	...	25Cr-20Ni	8	(2)(4)	75	30
	TP316H	S31609	...	16Cr-12Ni-2Mo	8	...	75	30

Table A-8 Temperatures 1,200°F and Above

<i>E</i> or <i>F</i>	Maximum Allowable Stress Values in Tension, ksi, for Metal Temperature, °F, Not Exceeding							Type or Grade	Spec. No.
	1,200	1,250	1,300	1,350	1,400	1,450	1,500		
Seamless Pipe and Tube									
1.00	6.1	4.7	3.7	2.9	2.3	1.8	1.4	TP304H	A213
1.00	5.2	4.0	3.1	2.4	1.9	1.6	1.3	...	
1.00	4.0	3.0	2.2	1.7	1.3	0.97	0.75	TP310H	
1.00	7.4	5.5	4.1	3.1	2.3	1.7	1.3	TP316H	
1.00	6.4	4.7	3.5	2.5	1.8	1.3	1.0	TP316L	
1.00	5.4	4.1	3.2	2.5	1.9	1.5	1.1	TP321H	A213
1.00	7.9	5.9	4.4	3.2	2.5	1.8	1.3	TP347H	
1.00	7.9	5.9	4.4	3.2	2.5	1.8	1.3	TP348H	
1.00	6.1	4.7	3.7	2.9	2.3	1.8	1.4	TP304H	A312
1.00	5.2	4.0	3.1	2.4	1.9	1.6	1.3	...	
1.00	4.0	3.0	2.2	1.7	1.3	0.97	0.75	TP310H	
1.00	7.4	5.5	4.1	3.1	2.3	1.7	1.3	TP316H	
1.00	5.4	4.1	3.2	2.5	1.9	1.5	1.1	TP321H	A312
1.00	7.9	5.9	4.4	3.2	2.5	1.8	1.3	TP347H	
1.00	7.9	5.9	4.4	3.2	2.5	1.8	1.3	TP348H	
1.00	6.1	4.7	3.7	2.9	2.3	1.8	1.4	TP304H	A376
1.00	7.4	5.5	4.1	3.1	2.3	1.7	1.3	TP316H	
1.00	5.4	4.1	3.2	2.5	1.9	1.5	1.1	TP321H	
1.00	7.9	5.9	4.4	3.2	2.5	1.8	1.3	TP347H	
1.00	6.6	4.2	2.0	1.6	1.1	1.0	0.80	...	B163
1.00	7.4	5.9	4.7	3.8	3.0	2.4	1.9	...	
1.00	15.3	14.5	11.2	8.7	6.6	5.1	3.9	...	B167
1.00	6.6	4.2	2.0	1.6	1.1	1.0	0.80	...	B407
1.00	7.4	5.9	4.7	3.8	3.0	2.4	1.9	...	
1.00	13.6	10.9	8.8	7.0	5.6	4.5	3.6	...	B622
Welded Pipe and Tube — Without Filler Metal									
0.85	5.2	4.0	3.2	2.5	2.0	1.6	1.2	TP304H	A249
0.85	4.4	3.4	2.6	2.0	1.6	1.4	1.1	...	
0.85	3.4	2.6	1.9	1.4	1.1	0.82	0.64	TP310H	
0.85	6.3	4.7	3.5	2.6	1.9	1.5	1.1	TP316H	
0.85	4.6	3.5	2.7	2.1	1.6	1.3	1.0	TP321H	A249
0.85	6.7	5.0	3.7	2.7	2.1	1.6	1.1	TP347H	
0.85	6.7	5.0	3.7	2.7	2.1	1.6	1.1	TP348H	
0.85	5.2	4.0	3.2	2.5	2.0	1.6	1.2	TP304H	A312
0.85	4.4	3.4	2.6	2.0	1.6	1.4	1.1	...	
0.85	3.4	2.6	1.9	1.4	1.1	0.82	0.64	TP310H	
0.85	6.3	4.7	3.5	2.6	1.9	1.5	1.1	TP316H	

Table A-8 Temperatures 1,200°F and Above (Cont'd)

Spec. No.	Type or Grade	UNS Alloy No.	Temper	Nominal Composition	P-No.	Notes	Specified Minimum Tensile, ksi	Specified Minimum Yield, ksi
Welded Pipe and Tube — Without Filler Metal (Cont'd)								
A312	TP321H	S32109	...	18Cr-10Ni-Ti	8	...	75	30
	TP347H	S32709	...	18Cr-10Ni-Cb	8	...	75	30
A409	...	S30815	...	21Cr-11Ni-N	8	(1)	87	45
B619	...	R30556	Annealed	Ni-Fe-Cr-Co-Mo-W	45	(1)	100	45
B626	...	R30556	Annealed	Ni-Fe-Cr-Co-Mo-W	45	(1)	100	45
Welded Pipe and Tube — Filler Metal Added								
A358	1 & 3	S30815	...	21Cr-11Ni-N	8	(1)	87	45
	2	S30815	...	21Cr-11Ni-N	8	(1)	87	45
A409	...	S30815	...	21Cr-11Ni-N	8	(1)	87	45
B546	...	N06617	Annealed	52Ni-22Cr-13Co-9Mo	43	...	95	35
Plate								
A240	304	S30400	...	18Cr-8Ni	8	(2)(3)	75	30
	...	S30815	...	21Cr-11Ni-N	8	(1)	87	45
	310S	S31008	...	25Cr-20Ni	8	(2)(3)(4)	75	30
	316	S31600	...	16Cr-12Ni-2Mo	8	(2)(3)	75	30
	316L	S31603	...	16Cr-12Ni-2Mo	8	(1)	70	25
A240	321	S32100	...	18Cr-10Ni-Ti	8	(2)(3)	75	30
	347	S34700	...	18Cr-10Ni-Cb	8	(2)(3)	75	30
	348	S34800	...	18Cr-10Ni-Cb	8	(1)(2)(3)	75	30
B168	...	N06617	Annealed	52Ni-22Cr-13Co-9Mo	43	...	95	35
B409	...	N08800	Annealed	Ni-Cr-Fe	45	(3)	75	30
	...	N08810	Annealed	Ni-Cr-Fe	45	(3)	65	25
Plate, Sheet, and Strip								
B435	...	R30556	Annealed	Ni-Fe-Cr-Co-Mo-W	45	(1)	100	45
Bars, Rods, and Shapes								
A479	...	S30815	...	21Cr-11Ni-N	8	(1)	87	45
	TP316L	S31603	...	16Cr-12Ni-2Mo	8	(1)(5)	70	25
B166	...	N06617	Annealed	52Ni-22Cr-13Co-9Mo	43	...	95	36
B408	...	N08800	Annealed	Ni-Cr-Fe	45	...	75	30
	...	N08810	Annealed	Ni-Cr-Fe	45	...	65	25
B572	...	R30556	Annealed	Ni-Fe-Cr-Co-Mo-W	45	(1)	100	45
Forgings								
A182	F304H	S30409	...	18Cr-8Ni	8	...	75	30
	...	S30815	...	21Cr-11Ni-N	8	(1)	87	45
	F310H	S31009	...	25Cr-20Ni	8	(1)(2)(4)	75	30
	F316H	S31609	...	16Cr-12Ni-2Mo	8	...	75	30
	F316L	S31603	...	16Cr-12Ni-2Mo	8	(1)	70	25

Table A-8 Temperatures 1,200°F and Above (Cont'd)

<i>E</i> or <i>F</i>	Maximum Allowable Stress Values in Tension, ksi, for Metal Temperature, °F, Not Exceeding							Type or Grade	Spec. No.
	1,200	1,250	1,300	1,350	1,400	1,450	1,500		
Welded Pipe and Tube — Without Filler Metal (Cont'd)									
0.85	4.6	3.5	2.7	2.1	1.6	1.3	1.0	TP321H	A312
0.85	6.7	5.0	3.7	2.7	2.1	1.6	1.1	TP347H	
0.85	4.4	3.4	2.6	2.0	1.6	1.4	1.1	...	A409
0.85	11.6	9.3	7.5	6.0	4.8	3.8	3.1	...	B619
0.85	11.6	9.3	7.5	6.0	4.8	3.8	3.1	...	B626
Welded Pipe and Tube — Filler Metal Added									
1.00	5.2	4.0	3.1	2.4	1.9	1.6	1.3	1 & 3	A358
0.90	4.7	3.6	2.8	2.2	1.7	1.4	1.2	2	
0.80	4.2	3.2	2.5	1.9	1.5	1.3	1.0	...	A409
0.85	13.0	12.3	9.5	7.4	5.6	4.3	3.3	...	B546
Plate									
1.00	6.1	4.7	3.7	2.9	2.3	1.8	1.4	304	A240
1.00	5.2	4.0	3.1	2.4	1.9	1.6	1.3	...	
1.00	2.5	1.5	0.80	0.50	0.40	0.30	0.20	310S	
1.00	7.4	5.5	4.1	3.1	2.3	1.7	1.3	316	
1.00	6.4	4.7	3.5	2.5	1.8	1.3	1.0	316L	
1.00	3.6	2.6	1.7	1.1	0.80	0.50	0.30	321	A240
1.00	4.4	3.3	2.2	1.5	1.2	0.90	0.80	347	
1.00	4.4	3.3	2.2	1.5	1.2	0.90	0.80	348	
1.00	15.3	14.5	11.2	8.7	6.6	5.1	3.9	...	B168
1.00	6.6	4.2	2.0	1.6	1.1	1.0	0.80	...	B409
1.00	7.4	5.9	4.7	3.8	3.0	2.4	1.9	...	
Plate, Sheet, and Strip									
1.00	13.6	10.9	8.8	7.0	5.6	4.5	3.6	...	B435
Bars, Rods, and Shapes									
1.00	5.2	4.0	3.1	2.4	1.9	1.6	1.3	...	A479
1.00	6.4	4.7	3.5	2.5	1.8	1.3	1.0	TP316L	
1.00	15.3	14.5	11.2	8.7	6.6	5.1	3.9	...	B166
1.00	6.6	4.2	2.0	1.6	1.1	1.0	0.80	...	B408
1.00	7.4	5.9	4.7	3.8	3.0	2.4	1.9	...	
1.00	13.6	10.9	8.8	7.0	5.6	4.5	3.6	...	B572
Forgings									
1.00	6.1	4.7	3.7	2.9	2.3	1.8	1.4	F304H	A182
1.00	5.2	4.0	3.1	2.4	1.9	1.6	1.3	...	
1.00	4.0	3.0	2.2	1.7	1.3	0.97	0.75	F310H	
1.00	7.4	5.5	4.1	3.1	2.3	1.7	1.3	F316H	
1.00	6.4	4.7	3.5	2.5	1.8	1.3	1.0	F316L	

Table A-8 Temperatures 1,200°F and Above (Cont'd)

Spec. No.	Type or Grade	UNS Alloy No.	Temper	Nominal Composition	P-No.	Notes	Specified Minimum Tensile, ksi	Specified Minimum Yield, ksi
Forgings (Cont'd)								
A182	F321H	S32109	...	18Cr-10Ni-Ti	8	...	75	30
	F347H	S34709	...	18Cr-10Ni-Cb	8	...	75	30
	F348H	S34809	...	18Cr-10Ni-Cb	8	...	75	30
B564	...	N06617	Annealed	52Ni-22Cr-13Co-9Mo	43	...	95	35
	...	N08800	Annealed	Ni-Cr-Fe	45	...	75	30
	...	N08810	Annealed	Ni-Cr-Fe	45	...	65	25
Fittings (Seamless and Welded)								
A403	WP304H	S30409	...	18Cr-8Ni	8	(1)	75	30
	WP316H	S31609	...	16Cr-12Ni-2Mo	8	(1)	75	30
	WP316L	S31603	...	16Cr-12Ni-2Mo	8	(1)	70	25
	WP321H	S32109	...	18Cr-10Ni-Ti	8	(1)	75	30
	WP347H	S34709	...	18Cr-10Ni-Cb	8	(1)	75	30
	WP348H	S34809	...	18Cr-10Ni-Cb	8	(1)	75	30
B366	...	R30556	Annealed	Ni-Fe-Cr-Co-Mo-W	45	(1)(6)	100	45
	...	R30556	Annealed	Ni-Fe-Cr-Co-Mo-W	45	(1)(7)	100	45

GENERAL NOTES:

- The tabulated specifications are ANSI/ASTM or ASTM. For ASME Boiler and Pressure Vessel Code applications, see related specifications in Section II of the ASME Code.
- The stress values in this Table may be interpolated to determine values for intermediate temperatures.
- The P-Numbers listed in this Table are identical to those adopted by the ASME Boiler and Pressure Vessel Code. Qualification of welding procedures, welders, and welding operators is required and shall comply with the ASME Boiler and Pressure Vessel Code, Section IX, except as modified by para. 127.5.
- Tensile strengths and allowable stresses shown in "ksi" are "thousands of pounds per square inch."
- The materials listed in this Table shall not be used at design temperatures above those for which allowable stress values are given.
- The tabulated stress values are $S \times E$ (weld joint efficiency factor) or $S \times F$ (material quality factor), as applicable. Weld joint efficiency factors are shown in Table 102.4.3.
- Pressure-temperature ratings of piping components, as published in standards referenced in this Code, may be used for components meeting the requirements of those standards. The allowable stress values given in this Table are for use in designing piping components which are not manufactured in accordance with referenced standards.
- All the materials listed are classified as austenitic [see Table 104.1.2(A)].
- The tabulated stress values that are shown in italics are at temperatures in the range where creep and stress rupture strength govern the selection of stresses.

Table A-8 Temperatures 1,200°F and Above (Cont'd)

<i>E</i> or <i>F</i>	Maximum Allowable Stress Values in Tension, ksi, for Metal Temperature, °F, Not Exceeding							Type or Grade	Spec. No.
	1,200	1,250	1,300	1,350	1,400	1,450	1,500		
Forgings (Cont'd)									
1.00	5.4	4.1	3.2	2.5	1.9	1.5	1.1	F321H	A182
1.00	7.9	5.9	4.4	3.2	2.5	1.8	1.3	F347H	
1.00	7.9	5.9	4.4	3.2	2.5	1.8	1.3	F348H	
1.00	15.3	14.5	11.2	8.7	6.6	5.1	3.9	...	B564
1.00	6.6	4.2	2.0	1.6	1.1	1.0	0.80	...	
1.00	7.4	5.9	4.7	3.8	3.0	2.4	1.9	...	
Fittings (Seamless and Welded)									
1.00	6.1	4.7	3.7	2.9	2.3	1.8	1.4	WP304H	A403
1.00	7.4	5.5	4.1	3.1	2.3	1.7	1.3	WP316H	
1.00	6.4	4.7	3.5	2.5	1.8	1.3	1.0	WP316L	
1.00	5.4	4.1	3.2	2.5	1.9	1.5	1.1	WP321H	
1.00	7.9	5.9	4.4	3.2	2.5	1.8	1.3	WP347H	
1.00	7.9	5.9	4.4	3.2	2.5	1.8	1.3	WP348H	
1.00	13.6	10.9	8.8	7.0	5.6	4.5	3.6	...	B366
0.85	11.6	9.3	7.5	6.0	4.8	3.8	3.1	...	

NOTES:

- (1) THIS MATERIAL IS NOT ACCEPTABLE FOR USE ON BOILER EXTERNAL PIPING — SEE FIG. 100.1.2(A.1), FIG. 100.1.2(A.2), FIG. 100.1.2(B.1), FIG. 100.1.2(B.2), AND FIG. 100.1.2(B.3).
- (2) These allowable stress values shall be used only if the carbon content of the material is 0.04% or higher.
- (3) These allowable stress values tabulated shall be used only if the material is heat treated by heating to a minimum temperature of 1,900°F and quenching in water or rapidly cooling by other means.
- (4) These allowable stress values shall be used only when the grain size of the material is ASTM No. 6 or coarser.
- (5) These allowable stress values shall be used only when Supplementary Requirement S1 per ASTM A479 has been specified.
- (6) Seamless.
- (7) Welded—all filler metal, including consumable insert material, shall comply with the requirements of Section IX of the ASME Boiler and Pressure Vessel Code.

Table A-9 Titanium and Titanium Alloys

Spec. No.	Grade	Condition	Nominal Composition	P-No.	Notes	Specified Minimum Tensile, ksi	Specified Minimum Yield, ksi	E or F
Seamless Pipe and Tube								
B338	1	Annealed	Ti	51	(1)	35	25	1.00
	2	Annealed	Ti	51	(1)	50	40	1.00
	3	Annealed	Ti	52	(1)	65	55	1.00
	7	Annealed	Ti-Pd	51	(1)	50	40	1.00
	12	Annealed	Ti-Mo-Ni	52	(1)	70	50	1.00
B861	1	Annealed	Ti	51	(1)	35	25	1.00
	2	Annealed	Ti	51	(1)	50	40	1.00
	3	Annealed	Ti	52	(1)	65	55	1.00
	7	Annealed	Ti-Pd	51	(1)	50	40	1.00
	12	Annealed	Ti-Mo-Ni	52	(1)	70	50	1.00
Welded Pipe and Tube								
B338	1	Annealed	Ti	51	(1)(2)	35	25	0.85
	2	Annealed	Ti	51	(1)(2)	50	40	0.85
	3	Annealed	Ti	52	(1)(2)	65	55	0.85
	7	Annealed	Ti-Pd	51	(1)(2)	50	40	0.85
	12	Annealed	Ti-Mo-Ni	52	(1)(2)	70	50	0.85
B862	1	Annealed	Ti	51	(1)(2)	35	25	0.85
	2	Annealed	Ti	51	(1)(2)	50	40	0.85
	3	Annealed	Ti	52	(1)(2)	65	55	0.85
	7	Annealed	Ti-Pd	51	(1)(2)	50	40	0.85
	12	Annealed	Ti-Mo-Ni	52	(1)(2)	70	50	0.85
Plate, Sheet, and Strip								
B265	1	Annealed	Ti	51	(1)	35	25	1.00
	2	Annealed	Ti	51	(1)	50	40	1.00
	3	Annealed	Ti	52	(1)	65	55	1.00
	7	Annealed	Ti-Pd	51	(1)	50	40	1.00
	12	Annealed	Ti-Mo-Ni	52	(1)	70	50	1.00
Forgings								
B381	F1	Annealed	Ti	51	(1)	35	25	1.00
	F2	Annealed	Ti	51	(1)	50	40	1.00
	F3	Annealed	Ti	52	(1)	65	55	1.00
	F7	Annealed	Ti-Pd	51	(1)	50	40	1.00
	F12	Annealed	Ti-Mo-Ni	52	(1)	70	50	1.00

Table A-9 Titanium and Titanium Alloys

Maximum Allowable Stress Values in Tension, ksi, for Metal Temperature, °F, Not Exceeding												Spec. No.
100	150	200	250	300	350	400	450	500	550	600	Grade	
Seamless Pipe and Tube												
10.0	9.3	8.3	7.4	6.6	6.0	5.5	5.1	4.7	4.2	3.6	1	B338
14.3	13.7	12.4	11.3	10.3	9.5	8.8	8.2	7.6	7.0	6.5	2	
18.6	17.5	15.8	14.2	12.8	11.5	10.3	9.3	8.5	7.9	7.4	3	
14.3	13.7	12.4	11.3	10.3	9.5	8.8	8.2	7.6	7.0	6.5	7	
20.0	20.0	18.7	17.4	16.2	15.2	14.3	13.6	13.1	12.7	12.3	12	
10.0	9.3	8.3	7.4	6.6	6.0	5.5	5.1	4.7	4.2	3.6	1	B861
14.3	13.7	12.4	11.3	10.3	9.5	8.8	8.2	7.6	7.0	6.5	2	
18.6	17.5	15.8	14.2	12.8	11.5	10.3	9.3	8.5	7.9	7.4	3	
14.3	13.7	12.4	11.3	10.3	9.5	8.8	8.2	7.6	7.0	6.5	7	
20.0	20.0	18.7	17.4	16.2	15.2	14.3	13.6	13.1	12.7	12.3	12	
Welded Pipe and Tube												
8.5	7.9	7.0	6.3	5.6	5.1	4.7	4.3	4.0	3.6	3.0	1	B338
12.1	11.6	10.6	9.6	8.8	8.1	7.5	7.0	6.5	6.0	5.5	2	
15.8	14.9	13.4	12.1	10.8	9.7	8.8	7.9	7.2	6.7	6.3	3	
12.1	11.6	10.6	9.6	8.8	8.1	7.5	7.0	6.5	6.0	5.5	7	
17.0	17.0	15.9	14.8	13.8	12.9	12.1	11.5	11.1	10.8	10.5	12	
8.5	7.9	7.0	6.3	5.6	5.1	4.7	4.3	4.0	3.6	3.0	1	B862
12.1	11.6	10.6	9.6	8.8	8.1	7.5	7.0	6.5	6.0	5.5	2	
15.8	14.9	13.4	12.1	10.8	9.7	8.8	7.9	7.2	6.7	6.3	3	
12.1	11.6	10.6	9.6	8.8	8.1	7.5	7.0	6.5	6.0	5.5	7	
17.0	17.0	15.9	14.8	13.8	12.9	12.1	11.5	11.1	10.8	10.5	12	
Plate, Sheet, and Strip												
10.0	9.3	8.3	7.4	6.6	6.0	5.5	5.1	4.7	4.2	3.6	1	B265
14.3	13.7	12.4	11.3	10.3	9.5	8.8	8.2	7.6	7.0	6.5	2	
18.6	17.5	15.8	14.2	12.8	11.5	10.3	9.3	8.5	7.9	7.4	3	
14.3	13.7	12.4	11.3	10.3	9.5	8.8	8.2	7.6	7.0	6.5	7	
20.0	20.0	18.7	17.4	16.2	15.2	14.3	13.6	13.1	12.7	12.3	12	
Forgings												
10.0	9.3	8.3	7.4	6.6	6.0	5.5	5.1	4.7	4.2	3.6	F1	B381
14.3	13.7	12.4	11.3	10.3	9.5	8.8	8.2	7.6	7.0	6.5	F2	
18.6	17.5	15.8	14.2	12.8	11.5	10.3	9.3	8.5	7.9	7.4	F3	
14.3	13.7	12.4	11.3	10.3	9.5	8.8	8.2	7.6	7.0	6.5	F7	
20.0	20.0	18.7	17.4	16.2	15.2	14.3	13.6	13.1	12.7	12.3	F12	

Table A-9 Titanium and Titanium Alloys (Cont'd)

Spec. No.	Grade	Condition	Nominal Composition	P-No.	Notes	Specified Minimum Tensile, ksi	Specified Minimum Yield, ksi	<i>E</i> or <i>F</i>
Bars and Billets								
B348	1	Annealed	Ti	51	(1)	35	25	1.00
	2	Annealed	Ti	51	(1)	50	40	1.00
	3	Annealed	Ti	52	(1)	65	55	1.00
	7	Annealed	Ti-Pd	51	(1)	50	40	1.00
	12	Annealed	Ti-Mo-Ni	52	(1)	70	50	1.00
Castings								
B367	C-2	As-cast	Ti	50	(1)(3)	50	40	0.80

GENERAL NOTES:

- The tabulated specifications are ANSI/ASTM or ASTM. For ASME Boiler and Pressure Vessel Code applications, see related specifications in Section II of the ASME Code.
- The stress values in this Table may be interpolated to determine values for intermediate temperatures.
- The P-Numbers listed in this Table are identical to those adopted by the ASME Boiler and Pressure Vessel Code. Qualification of welding procedures, welders, and welding operators is required and shall comply with the ASME Boiler and Pressure Vessel Code, Section IX, except as modified by para. 127.5.
- Tensile strengths and allowable stresses shown in “ksi” are “thousands of pounds per square inch.”
- The materials listed in this Table shall not be used at design temperatures above those for which allowable stress values are given.
- The tabulated stress values are $S \times E$ (weld joint efficiency factor) or $S \times F$ (material quality factor), as applicable. Weld joint efficiency factors are shown in Table 102.4.3.
- Pressure-temperature ratings of piping components, as published in standards referenced in this Code, may be used for components meeting the requirements of those standards. The allowable stress values given in this Table are for use in designing piping components which are not manufactured in accordance with referenced standards.
- The γ coefficient equals 0.4 [see Table 104.1.2(A)].
- The tabulated stress values that are shown in italics are at temperatures in the range where creep and stress rupture strength govern the selection of stresses.
- See para. 124.1.2 for lower temperature limits.

Table A-9 Titanium and Titanium Alloys (Cont'd)

Maximum Allowable Stress Values in Tension, ksi, for Metal Temperature, °F, Not Exceeding												Spec. No.
100	150	200	250	300	350	400	450	500	550	600	Grade	
												Bars and Billets
10.0	9.3	8.3	7.4	6.6	6.0	5.5	5.1	4.7	4.2	3.6	1	B348
14.3	13.7	12.4	11.3	10.3	9.5	8.8	8.2	7.6	7.0	6.5	2	
18.6	17.5	15.8	14.2	12.8	11.5	10.3	9.3	8.5	7.9	7.4	3	
14.3	13.7	12.4	11.3	10.3	9.5	8.8	8.2	7.6	7.0	6.5	7	
20.0	20.0	18.7	17.4	16.2	15.2	14.3	13.6	13.1	12.7	12.3	12	
												Castings
11.4	10.5	10.0	9.0	8.3	7.6	C-2	B367

NOTES:

- (1) THIS MATERIAL IS NOT ACCEPTABLE FOR USE ON BOILER EXTERNAL PIPING — SEE FIG. 100.1.2(A.1), FIG. 100.1.2(A.2), FIG. 100.1.2(B.1), FIG. 100.1.2(B.2), AND FIG. 100.1.2(B.3).
- (2) Filler metal shall not be used in the manufacture of welded pipe or tubing.
- (3) Welding of this material is not permitted.

Table A-10 Bolts, Nuts, and Studs

Spec. No.	Grade	Type or Class	Nominal Composition	Material Category / UNS No.	Notes	Specified Minimum Tensile, ksi	Specified Minimum Yield, ksi
Carbon Steel							
A194	1, 2, 2H	Carbon steel	(1)
A307	B	...	C	Carbon steel	(2)(3)(4)	60	...
A449	C	Carbon steel	(2)(5)(6)	120	...
	C	Carbon steel	(2)(5)(7)	105	...
	C	Carbon steel	(2)(5)(8)	90	...
Low and Intermediate Alloy Steel							
A193	B5	...	5Cr- $\frac{1}{2}$ Mo	Alloy steel	(5)(9)(10)	100	80
	B7	...	1Cr- $\frac{1}{5}$ Mo	Alloy steel	(11)	125	105
	B7	...	1Cr- $\frac{1}{5}$ Mo	Alloy steel	(12)	115	95
	B7	...	1Cr- $\frac{1}{5}$ Mo	Alloy steel	(13)	100	75
	B7M	...	1Cr- $\frac{1}{5}$ Mo	Alloy steel	(2)(11)	100	80
A193	B16	...	1Cr- $\frac{1}{2}$ Mo-V	Alloy steel	(11)	125	105
	B16	...	1Cr- $\frac{1}{2}$ Mo-V	Alloy steel	(12)	110	95
	B16	...	1Cr- $\frac{1}{2}$ Mo-V	Alloy steel	(13)	100	85
A194	3	...	5Cr- $\frac{1}{2}$ Mo-V	Alloy steel	(1)
	4	...	C-Mo	Alloy steel	(1)(14)
	7	...	Cr-Mo	Alloy steel	(1)
A320	L7	...	1Cr- $\frac{1}{5}$ Mo	Alloy steel	(2)(5)(15)	125	105
	L7M	...	1Cr- $\frac{1}{5}$ Mo	Alloy steel	(2)(11)	100	80
	L43	...	1 $\frac{3}{4}$ Ni- $\frac{3}{4}$ Cr- $\frac{1}{4}$ Mo	Alloy steel	(2)(5)(15)	125	105
A354	BC	Alloy steel	(5)(9)(11)	125	109
	BC	Alloy steel	(5)(9)(12)	115	99
	BD	Alloy steel	(5)(9)(11)	150	130
	BD	Alloy steel	(5)(9)(12)	140	120
Stainless Steels							
Austenitic							
A193	B8	1	18Cr-8Ni	S30400	(5)(16)(17)	75	30
	B8C	1	18Cr-10Ni-Cb	S34700	(5)(16)(17)	75	30
	B8M	1	16Cr-12Ni-2Mo	S31600	(5)(16)(17)	75	30
	B8T	1	18Cr-10Ni-Ti	S32100	(5)(16)(17)	75	30
A193	B8	2	18Cr-8Ni	S30400	(5)(18)(19)	125	100
	B8	2	18Cr-8Ni	S30400	(5)(18)(20)	115	80
	B8	2	18Cr-8Ni	S30400	(5)(18)(21)	105	65
	B8	2	18Cr-8Ni	S30400	(5)(18)(22)	100	50
A193	B8C	2	18Cr-10Ni-Cb	S34700	(5)(18)(19)	125	100
	B8C	2	18Cr-10Ni-Cb	S34700	(5)(18)(20)	115	80
	B8C	2	18Cr-10Ni-Cb	S34700	(5)(18)(21)	105	65
	B8C	2	18Cr-10Ni-Cb	S34700	(5)(18)(22)	100	50
A193	B8M	2	16Cr-12Ni-2Mo	S31600	(5)(18)(19)	110	80
	B8M	2	16Cr-12Ni-2Mo	S31600	(5)(18)(20)	100	80
	B8M	2	16Cr-12Ni-2Mo	S31600	(5)(18)(21)	95	75
	B8M	2	16Cr-12Ni-2Mo	S31600	(5)(18)(22)	90	65
A193	B8T	2	18Cr-10Ni-Ti	S32100	(5)(18)(19)	125	100
	B8T	2	18Cr-10Ni-Ti	S32100	(5)(18)(20)	115	80
	B8T	2	18Cr-10Ni-Ti	S32100	(5)(18)(21)	105	65
	B8T	2	18Cr-10Ni-Ti	S32100	(5)(18)(22)	100	50

Table A-10 Bolts, Nuts, and Studs

Maximum Allowable Stress Values in Tension, ksi, for Metal Temperature, °F, Not Exceeding																				Grade	Spec. No.	
100	200	300	350	400	450	500	600	650	700	750	800	850	900	950	1,000	1,050	1,100	1,150	1,200			
Carbon Steel																						
...	1, 2, 2H	A194
7.0	7.0	7.0	...	7.0	B	A307
23.0	23.0	23.0	...	23.0	...	23.0	23.0	A449
20.2	20.2	20.2	...	20.2	...	20.2	20.2	
14.5	14.5	14.5	...	14.5	...	14.5	14.5	
Low and Intermediate Alloy Steel																						
20.0	20.0	20.0	...	20.0	...	20.0	20.0	20.0	20.0	20.0	18.5	14.5	10.4	7.6	5.6	4.2	3.1	2.0	1.3	B5	A193	
25.0	25.0	25.0	...	25.0	...	25.0	25.0	25.0	25.0	23.6	21.0	16.3	12.5	8.5	4.5	B7		
23.0	23.0	23.0	...	23.0	...	23.0	23.0	23.0	23.0	22.2	20.0	16.3	12.5	8.5	4.5	B7		
18.8	18.8	18.8	...	18.8	...	18.8	18.8	18.8	18.8	18.8	18.0	16.3	12.5	8.5	4.5	B7		
20.0	20.0	20.0	...	20.0	...	20.0	20.0	20.0	20.0	20.0	18.5	16.5	12.5	8.5	4.5	B7M		
25.0	25.0	25.0	...	25.0	...	25.0	25.0	25.0	25.0	25.0	25.0	23.5	20.5	16.0	11.0	6.3	2.8	B16	A193	
22.0	22.0	22.0	...	22.0	...	22.0	22.0	22.0	22.0	22.0	22.0	21.0	18.5	15.3	11.0	6.3	2.8	B16		
20.0	20.0	20.0	...	20.0	...	20.0	20.0	20.0	20.0	20.0	20.0	18.8	16.7	14.3	11.0	6.3	2.8	B16		
...	3	A194
...	4	
...	7	
25.0	25.0	25.0	...	25.0	...	25.0	25.0	25.0	25.0	L7	A320
20.0	20.0	20.0	...	20.0	...	20.0	20.0	20.0	20.0	20.0	18.5	16.3	12.5	8.5	4.5	L7M		
25.0	25.0	25.0	...	25.0	...	25.0	25.0	25.0	25.0	L43	
25.0	25.0	25.0	...	25.0	...	25.0	25.0	25.0	BC	A354
23.0	23.0	23.0	...	23.0	...	23.0	23.0	23.0	BC	
30.0	30.0	30.0	...	30.0	...	30.0	30.0	30.0	BD	
28.0	28.0	28.0	...	28.0	...	28.0	28.0	28.0	BD	
Stainless Steels																						
Austenitic																						
18.8	16.7	15.0	...	13.8	...	12.9	12.1	12.0	11.8	11.5	11.2	11.0	10.8	10.6	10.4	10.1	9.8	7.7	6.1	B8	A193	
18.8	17.9	16.4	...	15.5	...	15.0	14.3	14.1	13.8	13.7	13.6	13.5	13.5	13.4	13.4	12.1	9.1	6.1	4.4	B8C		
18.8	17.7	15.6	...	14.3	...	13.3	12.6	12.3	12.1	11.9	11.7	11.6	11.5	11.4	11.3	11.2	11.0	9.8	7.4	B8M		
18.8	17.8	16.5	...	15.3	...	14.3	13.5	13.3	12.9	12.7	12.5	12.4	12.3	12.1	12.0	9.6	6.9	5.0	3.6	B8T		
25.0	B8	A193
20.0	B8	
18.8	B8	
18.8	B8	
25.0	B8C	A193
20.0	B8C	
18.8	B8C	
18.8	B8C	
22.0	22.0	22.0	...	22.0	...	22.0	22.0	22.0	22.0	22.0	B8M	A193
20.0	20.0	20.0	...	20.0	...	20.0	20.0	20.0	20.0	20.0	B8M	
18.8	17.7	16.3	...	16.3	...	16.3	16.3	16.3	16.3	16.3	B8M	
18.8	17.7	15.6	...	14.3	...	13.3	12.5	12.5	12.5	12.5	B8M	
25.0	B8T	A193
20.0	B8T	
18.8	B8T	
18.8	B8T	

(16)

Table A-10 Bolts, Nuts, and Studs (Cont'd)

Spec. No.	Grade	Type or Class	Nominal Composition	Material Category / UNS No.	Notes	Specified Minimum Tensile, ksi	Specified Minimum Yield, ksi
Stainless Steels (Cont'd)							
Austenitic (Cont'd)							
A194	8	...	18Cr-8Ni	S30400	(1)
	8C	...	18Cr-10Ni-Cb	S34700	(1)
A194	8M	...	16Cr-12Ni-Mo	S31600	(1)
	8T	...	18Cr-10Ni-Ti	S32100	(1)
	8F	...	18Cr-8Ni-Fm	...	(1)
A320	B8	1	18Cr-8Ni	S30400	(5)(18)	75	30
	B8	1	18Cr-8Ni	S30400	(5)(23)	75	30
	B8	2	18Cr-8Ni	S30400	(5)(18)(22)	100	50
	B8	2	18Cr-8Ni	S30400	(5)(18)(21)	105	65
	B8	2	18Cr-8Ni	S30400	(5)(18)(20)	115	80
	B8	2	18Cr-8Ni	S30400	(5)(18)(19)	125	100
A320	B8C	1	18Cr-10Ni-Cb	S34700	(5)	75	30
	B8C	1	18Cr-10Ni-Cb	S34700	(5)(23)	75	30
	B8C	2	18Cr-10Ni-Cb	S34700	(5)(18)(22)	100	50
	B8C	2	18Cr-10Ni-Cb	S34700	(5)(18)(21)	105	65
	B8C	2	18Cr-10Ni-Cb	S34700	(5)(18)(20)	115	80
	B8C	2	18Cr-10Ni-Cb	S34700	(5)(18)(19)	125	100
A320	B8M	1	16Cr-12Ni-2Mo	S31600	(5)	75	30
	B8M	1	16Cr-12Ni-2Mo	S31600	(5)(23)	75	30
	B8M	2	16Cr-12Ni-2Mo	S31600	(5)(18)(22)	90	50
	B8M	2	16Cr-12Ni-2Mo	S31600	(5)(18)(21)	95	65
	B8M	2	16Cr-12Ni-2Mo	S31600	(5)(18)(20)	100	80
	B8M	2	16Cr-12Ni-2Mo	S31600	(5)(18)(19)	110	95
A320	B8T	1	18Cr-10Ni-Ti	S32100	(5)	75	30
	B8T	1	18Cr-10Ni-Ti	S32100	(5)(23)	75	30
	B8T	2	18Cr-10Ni-Ti	S32100	(5)(18)(22)	100	50
	B8T	2	18Cr-10Ni-Ti	S32100	(5)(18)(21)	105	65
	B8T	2	18Cr-10Ni-Ti	S32100	(5)(18)(20)	115	80
	B8T	2	18Cr-10Ni-Ti	S32100	(5)(18)(19)	125	100
A453	660	A & B	15Cr-25Ni-Mo-Ti-V-B	S66286	(5)	130	85
A479	TP309H	...	23Cr-12Ni	S30909	(24)	75	30
	TP309H	...	23Cr-12Ni	S30909	...	75	30
	TP310H	...	25Cr-20Ni	S31009	(24)	75	30
	TP310H	...	25Cr-20Ni	S31009	...	75	30
Martensitic							
A193	B6	(410)	13Cr	S41000	(5)(10)	110	85
A194	6	...	13Cr	S41000	(1)
Precipitation Hardened							
A564	630	H1100	17Cr-4Ni-3.5Cu-0.04P	S17400	(5)(25)	140	115
Copper and Copper Alloys							
B150	C61400	(2)(26)(27)(28)	80	40
	C61400	(2)(26)(28)(29)	75	35
	C61400	(2)(26)(28)(30)	70	32
	C61400	(2)(26)(28)(31)	70	30

Table A-10 Bolts, Nuts, and Studs (Cont'd)

(16)

Maximum Allowable Stress Values in Tension, ksi, for Metal Temperature, °F, Not Exceeding																				Spec. No.		
100	200	300	350	400	450	500	600	650	700	750	800	850	900	950	1,000	1,050	1,100	1,150	1,200	Grade	Spec. No.	
																				Stainless Steels (Cont'd)		
																				Austenitic (Cont'd)		
...	8	A194
...	8C	
...	8M	A194
...	8T	
...	8F	
18.8	B8	A320
18.8	16.7	15.0	...	13.8	B8	
18.8	B8	
18.8	B8	
20.0	B8	
25.0	B8	
18.8	B8C	A320
18.8	18.4	17.1	...	16.0	B8C	
18.8	B8C	
18.8	B8C	
20.0	B8C	
25.0	B8C	
18.8	B8M	A320
18.8	17.7	15.6	...	14.3	B8M	
18.8	B8M	
18.8	B8M	
20.0	B8M	
25.0	B8M	
18.8	B8T	A320
18.8	17.8	16.5	...	15.3	B8T	
18.8	B8T	
18.8	B8T	
20.0	B8T	
25.0	B8T	
21.3	21.3	21.3	21.3	21.3	21.3	21.3	21.3	21.3	21.3	21.3	21.3	21.3	21.3	21.3	21.3	660	A453
20.0	20.0	20.0	...	20.0	...	19.4	18.8	18.5	18.2	18.0	17.7	17.5	17.2	16.9	13.8	10.3	7.6	5.5	4.0	TP309H	A479	
20.0	17.5	16.1	...	15.1	...	14.4	13.9	13.7	13.5	13.3	13.1	12.9	12.7	12.5	12.3	10.3	7.6	5.5	4.0	TP309H		
20.0	17.6	16.1	...	15.1	...	14.3	13.7	13.5	13.3	13.1	12.9	12.7	12.5	12.3	12.1	10.3	7.6	5.5	4.0	TP310H		
20.0	20.0	20.0	...	19.9	...	19.3	18.5	18.2	17.9	17.7	17.4	17.2	16.9	16.7	13.8	10.3	7.6	5.5	4.0	TP310H		
																				Martensitic		
21.3	19.5	18.9	...	18.5	...	18.3	17.9	17.6	17.2	16.7	16.1	15.3	12.3	B6	A193
...	6	A194
																				Precipitation Hardened		
28.0	630	A564
																				Copper and Copper Alloys		
17.5	17.5	17.5	17.5	17.2	16.6	16.1	B150
17.5	17.5	17.5	17.5	17.2	16.6	16.1	
17.5	17.5	17.5	17.5	17.2	16.6	16.1	
17.5	17.5	17.5	17.5	17.2	16.6	16.1	

Table A-10 Bolts, Nuts, and Studs (Cont'd)

GENERAL NOTE: See para. 124.1.2 for lower temperature limits.

NOTES:

- (1) This is a product specification. Allowable stresses are not necessary. Limitations on metal temperature for materials covered by this specification for use under B31.1 are as follows:
 - (a) Grades 1 and 2, -20°F to 600°F
 - (b) Grade 2H, -20°F to 800°F
 - (c) Grades 3 and 7, -20°F to $1,100^{\circ}\text{F}$
 - (d) Grade 4, -20°F to 900°F
 - (e) Grades 6 and 8F, -20°F to 800°F
 - (f) Grades 8, 8C, 8M, and 8T, -20°F to $1,200^{\circ}\text{F}$
- (2) THIS MATERIAL IS NOT ACCEPTABLE FOR CONSTRUCTION OF PRESSURE-RETAINING PARTS OF BOILER EXTERNAL PIPING — SEE FIG. 100.1.2(A.1), FIG. 100.1.2(A.2), FIG. 100.1.2(B.1), FIG. 100.1.2(B.2), AND FIG. 100.1.2(B.3).
- (3) This material shall not be used above 400°F . The allowable stress value is 7,000 psi.
- (4) The allowable stress values listed in MSS SP-58 for this material may be used for pipe supporting elements designed in accordance with MSS SP-58.
- (5) These allowable stress values are established from a consideration of strength only and will be satisfactory for average service. For bolted joints, where freedom from leakage over a long period of time without retightening is required, lower stress values may be necessary as determined from the relative flexibility of the flange, bolt, and corresponding relaxation properties.
- (6) These allowable stress values apply to bolting materials less than or equal to 1 in. in diameter.
- (7) These allowable stress values apply to bolting materials greater than or equal to 1 in. in diameter and less than or equal to $1\frac{1}{2}$ in. in diameter.
- (8) These allowable stress values apply to bolting materials greater than or equal to $1\frac{1}{2}$ in. in diameter and less than or equal to 3 in. in diameter.
- (9) Between temperatures of -20°F and 400°F , allowable stress values equal to the lower of the following may be used: 20% of the specified tensile strength or 25% of the specified yield strength.
- (10) These allowable stress values apply to bolting materials 4 in. in diameter and smaller.
- (11) These allowable stress values apply to bolting materials $2\frac{1}{2}$ in. in diameter and smaller.
- (12) These allowable stress values apply to bolting materials larger than $2\frac{1}{2}$ in. in diameter but not larger than 4 in. in diameter.
- (13) These allowable stress values apply to bolting materials larger than 4 in. in diameter but not larger than 7 in. in diameter.
- (14) Upon prolonged exposures to temperatures above 875°F , the carbide phase of carbon-molybdenum steel may be converted to graphite.
- (15) Minimum tempering temperature shall be 800°F .
- (16) The allowable stress values tabulated for temperatures over $1,000^{\circ}\text{F}$ apply only if the carbon content of the material is 0.04% or higher.
- (17) The allowable stress values tabulated for temperatures over $1,000^{\circ}\text{F}$ apply only if the material is heat treated by heating to a minimum temperature of $1,900^{\circ}\text{F}$ and quenching in water or rapidly cooling by other means.
- (18) The hardness of this material, under the thread roots, shall not exceed Rockwell C35. The hardness shall be measured on a flat area, at least $\frac{1}{8}$ in. across, prepared by removing thread. No more material than necessary shall be removed to prepare the flat area. Hardness measurements shall be made at the same frequency as the tensile test.
- (19) These allowable stress values apply to bolting materials $\frac{3}{4}$ in. in diameter and smaller.
- (20) These allowable stress values apply to bolting materials larger than $\frac{3}{4}$ in. but not larger than 1 in. in diameter.
- (21) These allowable stress values apply to bolting materials larger than 1 in. but not larger than $1\frac{1}{4}$ in. in diameter.
- (22) These allowable stress values apply to bolting materials larger than $1\frac{1}{4}$ in. but not larger than $1\frac{1}{2}$ in. in diameter.
- (23) These allowable stress values apply to bolting material that has been carbide solution treated.
- (24) Due to relatively low yield strength of these materials, these higher allowable stress values were established at temperatures where the short-time tensile properties govern to permit the use of these alloys where slightly greater deformation is acceptable. These stress values exceed 67% but do not exceed 90% of the yield strength at temperature. Use of these stress values may result in dimensional changes due to permanent strain. These values should not be used for the flanges of gasketed joints or other applications where slight amounts of distortion can cause leakage or malfunction.
- (25) These allowable stress values apply to bolting materials 8 in. in diameter and smaller.
- (26) Welding or brazing of this material is not permitted.
- (27) These allowable stress values apply to bolting materials $\frac{1}{2}$ in. in diameter and smaller.
- (28) Tempered to HR50.
- (29) These allowable stress values apply to bolting materials greater than $\frac{1}{2}$ in. but not larger than 1 in. in diameter.
- (30) These allowable stress values apply to bolting materials greater than 1 in. but not larger than 2 in. in diameter.
- (31) These allowable stress values apply to bolting materials greater than 2 in. but not larger than 3 in. in diameter.

MANDATORY APPENDIX B THERMAL EXPANSION DATA

Begins on next page.

Table B-1 Thermal Expansion Data

Material	Coef- ficient	Temperature Range 70°F to																
		-325	-150	-50	70	200	300	400	500	600	700	800	900	1,000	1,100	1,200	1,300	1,400
Group 1 carbon and low alloy steels [Note (2)]	A	5.5	5.9	6.2	6.4	6.7	6.9	7.1	7.3	7.4	7.6	7.8	7.9	8.1	8.2	8.3	8.4	8.4
	B	-2.6	-1.6	-0.9	0	1.0	1.9	2.8	3.7	4.7	5.7	6.8	7.9	9.0	10.1	11.3	12.4	14.7
Group 2 low alloy steels [Note (3)]	A	6.0	6.5	6.7	7.0	7.3	7.4	7.6	7.7	7.8	7.9	8.0	8.1	8.2	8.3	8.4	8.4	8.5
	B	-2.9	-1.7	-1.0	0	1.1	2.0	3.0	4.0	5.0	6.0	7.0	8.1	9.2	10.3	11.4	12.5	13.5
5Cr-1Mo steels	A	5.6	6.0	6.2	6.4	6.7	6.9	7.0	7.1	7.2	7.2	7.3	7.4	7.5	7.6	7.6	7.7	7.8
	B	-2.7	-1.6	-0.9	0	1.0	1.9	2.8	3.7	4.6	5.5	6.4	7.4	8.4	9.3	10.3	11.4	12.4
9Cr-1Mo steels	A	5.0	5.4	5.6	5.8	6.0	6.2	6.3	6.4	6.5	6.6	6.7	6.8	6.9	7.0	7.1	7.2	7.2
	B	-2.4	-1.4	-0.8	0	0.9	1.7	2.5	3.3	4.1	5.0	5.9	6.8	7.7	8.7	9.7	10.6	11.6
Straight chromium stainless steels 12Cr to 13Cr steels	A	5.1	5.5	5.7	5.9	6.2	6.3	6.4	6.5	6.5	6.6	6.7	6.7	6.8	6.8	6.9	6.9	7.0
	B	-2.4	-1.5	-0.8	0	1.0	1.7	2.5	3.3	4.2	5.0	5.8	6.7	7.6	8.5	9.4	10.2	11.1
15Cr to 17Cr steels	A	4.5	4.9	5.1	5.3	5.5	5.7	5.8	5.9	6.0	6.1	6.2	6.2	6.3	6.4	6.4	6.5	6.5
	B	-2.1	-1.3	-0.7	0	0.9	1.6	2.3	3.0	3.8	4.6	5.4	6.2	7.0	7.9	8.7	9.5	10.4
27Cr steels	A	4.3	4.7	4.9	5.0	5.2	5.2	5.3	5.4	5.4	5.5	5.6	5.7	5.7	5.8	5.9	5.9	6.0
	B	-2.0	-1.2	-0.7	0	0.8	1.4	2.1	2.8	3.5	4.2	4.9	5.6	6.4	7.2	8.0	8.7	9.6
Austenitic stainless steels (304, 305, 316, 317, 321, 347, 348 19-9DL, XM-15, etc.)	A	7.5	8.0	8.2	8.5	8.9	9.2	9.5	9.7	9.9	10.0	10.1	10.2	10.3	10.4	10.6	10.7	10.8
	B	-3.6	-2.1	-1.2	0	1.4	2.5	3.8	5.0	6.3	7.5	8.8	10.2	11.5	12.9	14.3	15.8	17.2
Other austenitic stainless steels (309, 310, 315, XM-19, etc.)	A	7.1	7.6	7.8	8.2	8.5	8.7	8.9	9.1	9.2	9.3	9.4	9.5	9.6	9.7	9.8	9.9	10.1
	B	-3.4	-2.0	-1.1	0	1.3	2.4	3.5	4.7	5.8	7.0	8.2	9.5	10.7	12.0	13.3	14.7	16.1
Gray cast iron	A	5.8	5.9	6.1	6.3	6.5	6.7	6.8	7.0	7.2
	B	0	0.9	1.6	2.4	3.2	4.1	5.0	6.0	7.0	8.0
Ductile cast iron	A	...	4.9	5.3	5.7	6.0	6.3	6.6	6.8	7.0	7.1	7.3	7.4	7.5
	B	...	-1.3	-0.8	0	0.9	1.7	2.6	3.5	4.5	5.4	6.4	7.3	8.4

Table B-1 Thermal Expansion Data (Cont'd)

Material	Coef- ficient	Temperature Range 70°F to																
		-325	-150	-50	70	200	300	400	500	600	700	800	900	1,000	1,100	1,200	1,300	1,400
Monel (67Ni-30Cu) N04400	A	5.8	6.8	7.2	7.7	8.1	8.3	8.5	8.7	8.8	8.9	8.9	9.0	9.1	9.1	9.2	9.2	9.3
	B	-2.7	-1.8	-1.0	0	1.3	2.3	3.4	4.5	5.6	6.7	7.8	9.0	10.1	11.3	12.4	13.6	14.8
Nickel alloys N02200 and N02201	A	5.3	6.0	6.3	6.6	7.2	7.5	7.7	7.9	8.0	8.2	8.3	8.4	8.5	8.6	8.7	8.8	8.9
	B	-2.7	-1.7	-1.0	0	1.1	2.1	3.1	4.1	5.1	6.2	7.3	8.4	9.5	10.7	11.8	13.0	14.2
Nickel alloy N06022	A	6.9	6.9	6.9	6.9	7.0	7.0	7.2	7.3	7.5	7.7	7.9	8.1	8.3	8.5
	B	0	1.1	1.9	2.7	3.6	4.5	5.4	6.4	7.5	8.6	9.8	11.0	12.2	13.6
Nickel alloy N06600	A	5.5	6.1	6.4	6.8	7.1	7.3	7.5	7.6	7.8	7.9	8.0	8.2	8.3	8.4	8.6	8.7	8.9
	B	-2.6	-1.6	-0.9	0	1.1	2.0	3.0	3.9	5.0	6.0	7.0	8.1	9.3	10.4	11.6	12.9	14.2
Nickel alloy N06625	A	6.7	7.1	7.2	7.3	7.4	7.4	7.5	7.6	7.7	7.9	8.0	8.2	8.4	8.5
	B	0	1.1	2.0	2.9	3.8	4.7	5.6	6.6	7.7	8.8	9.9	11.1	12.3	13.6
Nickel alloys N08800 and N08810	A	5.9	6.9	7.4	7.9	8.4	8.6	8.8	8.9	9.0	9.1	9.2	9.3	9.4	9.5	9.6	9.7	9.8
	B	-2.8	-1.7	-1.1	0	1.3	2.4	3.5	4.6	5.7	6.9	8.1	9.3	10.5	11.8	13.0	14.4	15.7
Nickel alloy N08825	A	7.2	7.5	7.7	7.9	8.0	8.1	8.2	8.3	8.4	8.5	8.6
	B	-1.0	0	1.2	2.2	3.2	4.2	5.2	6.3	7.4	8.5	9.6
Nickel alloy N10276	A	6.0	6.3	6.5	6.7	6.9	7.1	7.2	7.4	7.5	7.6	7.7	7.8	7.9	8.0
	B	0	1.0	1.8	2.7	3.6	4.5	5.5	6.4	7.5	8.5	9.5	10.6	11.7	12.8
Copper alloys C1XXXX series	A	7.7	8.7	9.0	9.3	9.6	9.7	9.8	9.9	10.0
	B	-3.7	-2.3	-1.3	0	1.5	2.7	3.9	5.1	6.4
Bronze alloys	A	8.4	8.8	9.2	9.6	10.0	10.1	10.2	10.3	10.4	10.5	10.6	10.7	10.8	10.9	11.0
	B	-4.0	-2.3	-1.3	0	1.6	2.8	4.0	5.3	6.6	8.0	9.3	10.7	12.1	13.5	14.9
Brass alloys	A	8.2	8.5	9.0	9.3	9.8	10.0	10.2	10.5	10.7	10.9	11.2	11.4	11.6	11.9	12.1
	B	-3.9	-2.2	-1.3	0	1.5	2.8	4.1	5.4	6.8	8.2	9.8	11.4	13.0	14.7	16.4
Copper-nickel (70Cu-30Ni)	A	6.7	7.4	7.8	8.1	8.5	8.7	8.9	9.1	9.2	9.2
	B	-3.2	-2.0	-1.1	0	1.3	2.4	3.5	4.7	5.8	7.0
Aluminum alloys	A	9.9	10.9	11.6	12.1	13.0	13.3	13.6	13.9	14.2
	B	-4.7	-2.9	-1.7	0	2.0	3.7	5.4	7.2	9.0
Titanium alloys (Grades 1, 2, 3, 7, and 12)	A	4.5	4.6	4.7	4.8	4.8	4.9	4.9	5.0	5.1
	B	-0.6	0	0.7	1.3	1.9	2.5	3.1	3.8	4.5

A = Mean Coefficient of Thermal Expansion, 10⁻⁶in./in./°F

B = Linear Thermal Expansion, in./100 ft

in Going From 70°F to Indicated Temperature [Note (1)]

Table B-1 Thermal Expansion Data (Cont'd)

NOTES:

- (1) These data are for information and it is not to be implied that materials are suitable for all the temperature ranges shown.
 (2) Group 1 alloys (by nominal composition):

Carbon steels (C, C-Si, C-Mn, and C-Mn-Si)	$2\frac{1}{4}\text{Cr}-1\text{Mo}$
$\text{C}-\frac{1}{2}\text{Mo}$	$3\text{Cr}-1\text{Mo}$
$\frac{1}{2}\text{Cr}-\frac{1}{5}\text{Mo}-\text{V}$	$\frac{1}{2}\text{Ni}-\frac{1}{2}\text{Mo}-\text{V}$
$\frac{1}{2}\text{Cr}-\frac{1}{4}\text{Mo}-\text{Si}$	$\frac{1}{2}\text{Ni}-\frac{1}{2}\text{Cr}-\frac{1}{4}\text{Mo}-\text{V}$
$\frac{1}{2}\text{Cr}-\frac{1}{2}\text{Mo}$	$\frac{3}{4}\text{Ni}-\frac{1}{2}\text{Mo}-\text{Cr}-\text{V}$
$\frac{1}{2}\text{Cr}-\frac{1}{2}\text{Ni}-\frac{1}{4}\text{Mo}$	$\frac{3}{4}\text{Ni}-\frac{1}{2}\text{Mo}-\frac{1}{3}\text{Cr}-\text{V}$
$\frac{3}{4}\text{Cr}-\frac{1}{2}\text{Ni}-\text{Cu}$	$\frac{3}{4}\text{Ni}-\frac{1}{2}\text{Cu}-\text{Mo}$
$\frac{3}{4}\text{Cr}-\frac{3}{4}\text{Ni}-\text{Cu}-\text{Al}$	$\frac{3}{4}\text{Ni}-\frac{1}{2}\text{Cr}-\frac{1}{2}\text{Mo}-\text{V}$
$1\text{Cr}-\frac{1}{5}\text{Mo}$	$\frac{3}{4}\text{Ni}-1\text{Mo}-\frac{3}{4}\text{Cr}$
$1\text{Cr}-\frac{1}{5}\text{Mo}-\text{Si}$	$1\text{Ni}-\frac{1}{2}\text{Cr}-\frac{1}{2}\text{Mo}$
$1\text{Cr}-\frac{1}{2}\text{Mo}$	$1\frac{1}{4}\text{Ni}-1\text{Cr}-\frac{1}{2}\text{Mo}$
$1\text{Cr}-\frac{1}{2}\text{Mo}-\text{V}$	$1\frac{3}{4}\text{Ni}-\frac{3}{4}\text{Cr}-\frac{1}{4}\text{Mo}$
$1\frac{1}{4}\text{Cr}-\frac{1}{2}\text{Mo}$	$2\text{Ni}-\frac{3}{4}\text{Cr}-\frac{1}{4}\text{Mo}$
$1\frac{1}{4}\text{Cr}-\frac{1}{2}\text{Mo}-\text{Si}$	$2\text{Ni}-\frac{3}{4}\text{Cr}-\frac{1}{3}\text{Mo}$
$1\frac{3}{4}\text{Cr}-\frac{1}{2}\text{Mo}-\text{Cu}$	$2\frac{1}{2}\text{Ni}$
$2\text{Cr}-\frac{1}{2}\text{Mo}$	$3\frac{1}{2}\text{Ni}$
	$3\frac{1}{2}\text{Ni}-1\frac{3}{4}\text{Cr}-\frac{1}{2}\text{Mo}-\text{V}$

- (3) Group 2 alloys (by nominal composition):

Mn-V
 $\text{Mn}-\frac{1}{4}\text{Mo}$
 $\text{Mn}-\frac{1}{2}\text{Mo}$
 $\text{Mn}-\frac{1}{2}\text{Mo}-\frac{1}{4}\text{Ni}$
 $\text{Mn}-\frac{1}{2}\text{Mo}-\frac{1}{2}\text{Ni}$
 $\text{Mn}-\frac{1}{2}\text{Mo}-\frac{3}{4}\text{Ni}$

Table B-1 (SI) begins on the next page.

Table B-1 (SI) Thermal Expansion Data

Material		Coef- ficient	Temperature Range 20°C to												
			-200	-100	-50	20	50	75	100	125	150	175	200	225	250
Group 1 carbon and low alloy steels [Note (2)]	A	9.9	10.7	11.1	11.5	11.8	11.9	12.1	12.3	12.4	12.6	12.7	12.9	13.0	13.2
	B	-2.2	-1.3	-0.8	0	0.4	0.7	1.0	1.3	1.6	2.0	2.3	2.6	3.0	3.4
Group 2 low alloy steels [Note (3)]	A	10.8	11.7	12.0	12.6	12.8	13.0	13.1	13.2	13.4	13.5	13.6	13.7	13.8	13.9
	B	-2.4	-1.4	-0.8	0	0.4	0.7	1.0	1.4	1.7	2.1	2.4	2.8	3.2	3.6
5Cr-1Mo steels	A	10.1	10.8	11.2	11.5	11.8	12.0	12.1	12.3	12.4	12.5	12.6	12.6	12.7	12.8
	B	-2.2	-1.3	-0.8	0	0.4	0.7	1.0	1.3	1.6	1.9	2.3	2.6	2.9	3.3
9Cr-1Mo steels	A	9.0	9.8	10.1	10.5	10.6	10.7	10.9	11.0	11.1	11.2	11.3	11.4	11.5	11.6
	B	-2.0	-1.2	-0.7	0	0.3	0.6	0.9	1.2	1.4	1.7	2.0	2.3	2.6	3.0
Straight chromium stainless steels 12Cr to 13Cr steels	A	9.1	9.9	10.2	10.6	10.9	11.0	11.1	11.3	11.4	11.4	11.5	11.6	11.6	11.7
	B	-2.0	-1.2	-0.7	0	0.3	0.6	0.9	1.2	1.5	1.8	2.1	2.4	2.7	3.0
15Cr to 17Cr steels	A	8.1	8.8	9.1	9.6	9.7	9.9	10.0	10.1	10.2	10.3	10.4	10.5	10.6	10.7
	B	-1.8	-1.1	-0.6	0	0.3	0.5	0.8	1.1	1.3	1.6	1.9	2.2	2.4	2.7
27Cr steels	A	7.7	8.5	8.7	9.0	9.2	9.2	9.3	9.4	9.4	9.5	9.5	9.6	9.6	9.7
	B	-1.7	-1.0	-0.6	0	0.3	0.5	0.7	1.0	1.2	1.5	1.7	2.0	2.2	2.5
Austenitic stainless steels (304, 305, 316, 317, 321, 347, 348 19-9DL XM-15, etc.)	A	13.5	14.3	14.7	15.3	15.6	15.9	16.2	16.4	16.6	16.8	17.0	17.2	17.4	17.5
	B	-3.0	-1.7	-1.0	0	0.5	0.9	1.3	1.7	2.2	2.6	3.1	3.5	4.0	4.5
Other austenitic stainless steels (309, 310, 315, XM-19, etc.)	A	12.8	13.6	14.1	14.7	15.0	15.2	15.4	15.6	15.7	15.9	16.0	16.1	16.3	16.4
	B	-2.8	-1.6	-1.0	0	0.4	0.8	1.2	1.6	2.0	2.5	2.9	3.3	3.7	4.2
Gray cast iron	A	9.8	10.1	10.2	10.4	10.5	10.7	10.8	11.0	11.1	11.2	11.4
	B	0	0.3	0.6	0.8	1.1	1.4	1.7	2.0	2.3	2.6	2.9
Ductile cast iron	A	...	8.8	9.5	10.3	10.5	10.7	10.9	11.1	11.3	11.6	11.8	12.0	12.2	12.4
	B	...	-1.1	-0.7	0	0.3	0.6	0.9	1.2	1.5	1.8	2.1	2.5	2.8	3.1
Monel (67Ni-30Cu) N04400	A	10.4	12.2	13.0	13.8	14.1	14.4	14.6	14.8	15.0	15.1	15.3	15.4	15.5	15.6
	B	-2.3	-1.5	-0.9	0	0.4	0.8	1.2	1.6	1.9	2.3	2.8	3.2	3.6	4.0
Nickel alloys N02200 and N02201	A	9.6	10.8	11.4	11.9	12.4	12.7	13.0	13.3	13.5	13.7	13.9	14.0	14.2	14.3
	B	-2.2	-1.4	-0.8	0	0.4	0.7	1.0	1.4	1.8	2.1	2.5	2.9	3.3	3.6
Nickel alloy N06022	A	12.4	12.4	12.4	12.4	12.4	12.4	12.4	12.4	12.5	12.5	12.6
	B	0	0.4	0.7	1.0	1.3	1.6	1.9	2.2	2.6	2.9	3.2
Nickel alloy N06600	A	9.9	10.8	11.5	12.3	12.5	12.7	12.8	13.0	13.2	13.3	13.5	13.6	13.7	13.8
	B	-2.2	-1.3	-0.8	0	0.4	0.7	1.0	1.4	1.7	2.1	2.4	2.8	3.2	3.5
Nickel alloy N06625	A	12.0	12.4	12.6	12.8	12.9	13.0	13.1	13.2	13.2	13.2	13.3
	B	0	0.4	0.7	1.0	1.4	1.7	2.0	2.4	2.7	3.0	3.4
Nickel alloys N08800 and N08810	A	10.6	12.5	13.3	14.2	14.6	14.9	15.1	15.3	15.5	15.6	15.8	15.9	16.0	16.1
	B	-2.3	-1.5	-0.9	0	0.4	0.8	1.2	1.6	2.0	2.4	2.8	3.3	3.7	4.1
Nickel alloy N08825	A	12.9	13.5	13.6	13.7	13.9	14.0	14.2	14.3	14.4	14.4	14.5	14.6
	B	-0.9	0	0.4	0.8	1.1	1.5	1.8	2.2	2.6	3.0	3.3	3.7
Nickel alloy N10276	A	10.8	11.0	11.2	11.4	11.6	11.7	11.9	12.0	12.2	12.4	12.5
	B	0	0.3	0.6	0.9	1.2	1.5	1.8	2.2	2.5	2.8	3.2

Table B-1 (SI) Thermal Expansion Data

$A = \text{Mean Coefficient of Thermal Expansion, } 10^{-6} \text{ mm/mm/}^\circ\text{C}$ $B = \text{Linear Thermal Expansion, mm/m}$																				
in Going From 20°C to Indicated Temperature [Note (1)]																				
Temperature Range 20°C to																				
300	325	350	375	400	425	450	475	500	525	550	575	600	625	650	675	700	725	750	775	800
13.3	13.4	13.6	13.7	13.8	14.0	14.1	14.2	14.4	14.5	14.6	14.7	14.8	14.9	15.0	15.1	15.1	15.2	15.3	15.3	15.4
3.7	4.1	4.5	4.9	5.3	5.7	6.1	6.5	6.9	7.3	7.7	8.2	8.6	9.0	9.4	9.9	10.3	10.7	11.1	11.6	12.0
14.0	14.1	14.2	14.3	14.4	14.5	14.6	14.6	14.7	14.8	14.8	14.9	15.0	15.0	15.1	15.1	15.2	15.2	15.3	15.3	15.3
3.9	4.3	4.7	5.1	5.5	5.9	6.3	6.7	7.1	7.5	7.9	8.3	8.7	9.1	9.5	9.9	10.3	10.7	11.1	11.1	11.5
12.8	12.9	13.0	13.0	13.1	13.2	13.2	13.3	13.4	13.4	13.5	13.6	13.6	13.7	13.7	13.8	13.9	13.9	14.0	14.0	14.1
3.6	3.9	4.3	4.6	5.0	5.3	5.7	6.1	6.4	6.8	7.2	7.5	7.9	8.3	8.7	9.0	9.4	9.8	10.2	10.6	11.0
11.7	11.8	11.9	11.9	12.0	12.1	12.2	12.3	12.3	12.4	12.5	12.6	12.7	12.7	12.8	12.9	13.0	13.1	13.3	13.4	13.6
3.3	3.6	3.9	4.2	4.6	4.9	5.2	5.6	5.9	6.3	6.6	7.0	7.3	7.7	8.1	8.5	8.9	9.3	9.7	10.1	10.6
11.7	11.8	11.8	11.9	11.9	12.0	12.0	12.1	12.1	12.2	12.2	12.3	12.3	12.4	12.4	12.5	12.5	12.5	12.5	12.6	12.6
3.3	3.6	3.9	4.2	4.5	4.9	5.2	5.5	5.8	6.2	6.5	6.8	7.2	7.5	7.8	8.2	8.5	8.8	9.2	9.5	9.8
10.8	10.8	10.9	11.0	11.0	11.1	11.2	11.2	11.3	11.3	11.4	11.4	11.5	11.5	11.5	11.6	11.6	11.7	11.7	11.8	11.9
3.0	3.3	3.6	3.9	4.2	4.5	4.8	5.1	5.4	5.7	6.0	6.3	6.6	7.0	7.3	7.6	7.9	8.2	8.6	8.9	9.3
9.7	9.8	9.9	9.9	10.0	10.0	10.1	10.2	10.2	10.3	10.4	10.4	10.5	10.5	10.6	10.6	10.7	10.7	10.8	10.8	10.9
2.7	3.0	3.3	3.5	3.8	4.1	4.3	4.6	4.9	5.2	5.5	5.8	6.1	6.4	6.7	7.0	7.2	7.6	7.9	8.2	8.5
17.7	17.8	17.9	18.0	18.1	18.2	18.3	18.4	18.4	18.5	18.6	18.7	18.8	18.9	19.0	19.1	19.2	19.3	19.4	19.4	19.4
4.9	5.4	5.9	6.4	6.9	7.4	7.9	8.3	8.9	9.4	9.9	10.4	10.9	11.4	12.0	12.5	13.1	13.6	14.1	14.7	15.2
16.5	16.6	16.6	16.7	16.8	16.9	17.0	17.1	17.2	17.2	17.3	17.4	17.5	17.6	17.7	17.8	17.9	18.0	18.1	18.2	18.3
4.6	5.0	5.5	5.9	6.4	6.8	7.3	7.8	8.2	8.7	9.2	9.7	10.2	10.6	11.1	11.7	12.2	12.7	13.2	13.7	14.3
11.5	11.7	11.8	12.0	12.1	12.3	12.4	12.6	12.7	12.9	13.0
3.2	3.6	3.9	4.2	4.6	5.0	5.3	5.7	6.1	6.5	6.9
12.5	12.6	12.8	12.9	13.0	13.1	13.2	13.2	13.3	13.4	13.5
3.5	3.9	4.2	4.6	4.9	5.3	5.7	6.0	6.4	6.8	7.2
15.7	15.8	15.9	16.0	16.0	16.1	16.1	16.2	16.2	16.3	16.3	16.4	16.4	16.5	16.5	16.5	16.6	16.6	16.7	16.7	16.8
4.4	4.8	5.2	5.7	6.1	6.5	6.9	7.4	7.8	8.2	8.6	9.1	9.5	10.0	10.4	10.8	11.3	11.7	12.2	12.6	13.1
14.4	14.5	14.6	14.7	14.8	14.9	15.0	15.1	15.2	15.3	15.4	15.5	15.6	15.6	15.7	15.8	15.9	15.9	16.0	16.1	16.2
4.0	4.4	4.8	5.2	5.6	6.0	6.5	6.9	7.3	7.7	8.2	8.6	9.0	9.5	9.9	10.3	10.8	11.2	11.7	12.2	12.6
12.6	12.7	12.8	12.9	13.0	13.2	13.3	13.5	13.6	13.8	13.9	14.1	14.3	14.4	14.6	14.8	14.9	15.1	15.2	15.4	15.6
3.5	3.9	4.2	4.6	5.0	5.3	5.7	6.1	6.5	7.0	7.4	7.8	8.3	8.7	9.2	9.7	10.1	10.6	11.1	11.6	12.1
14.0	14.1	14.2	14.3	14.4	14.5	14.6	14.7	14.8	14.9	15.0	15.1	15.2	15.3	15.4	15.6	15.7	15.8	15.9	16.1	16.2
3.9	4.3	4.7	5.1	5.5	5.9	6.3	6.7	7.1	7.5	7.9	8.4	8.8	9.3	9.7	10.2	10.7	11.1	11.6	12.1	12.6
13.3	13.3	13.4	13.5	13.5	13.6	13.7	13.8	14.0	14.1	14.2	14.3	14.5	14.6	14.8	14.9	15.0	15.1	15.3	15.4	15.6
3.7	4.1	4.4	4.8	5.1	5.5	5.9	6.3	6.7	7.1	7.5	8.0	8.4	8.8	9.3	9.8	10.2	10.7	11.2	11.6	12.1
16.2	16.3	16.4	16.5	16.5	16.6	16.7	16.8	16.8	16.9	17.0	17.1	17.2	17.2	17.3	17.4	17.5	17.6	17.7	17.8	17.9
4.5	5.0	5.4	5.8	6.3	6.7	7.2	7.6	8.1	8.5	9.0	9.5	9.9	10.4	10.9	11.4	11.9	12.4	12.9	13.4	14.0
14.7	14.8	14.9	15.0	15.1	15.1	15.2	15.3	15.4	15.5	15.6
4.1	4.5	4.9	5.3	5.7	6.1	6.5	7.0	7.4	7.8	8.3
12.6	12.8	12.9	13.0	13.1	13.2	13.3	13.4	13.5	13.6	13.7	13.8	13.9	14.0	14.1	14.2	14.3	14.3	14.4	14.5	14.6
3.5	3.9	4.3	4.6	5.0	5.4	5.7	6.1	6.5	6.9	7.3	7.7	8.1	8.5	8.9	9.3	9.7	10.1	10.5	10.9	11.4

Table B-1 (SI) Thermal Expansion Data (Cont'd)

		} in Going From 20°C to Indicated Temperature [Note (1)]													
		Temperature Range 20°C to													
Material	Coef- ficient	-200	-100	-50	20	50	75	100	125	150	175	200	225	250	275
		Copper alloys C1XXXX series	A	13.9	15.7	16.2	16.7	17.0	17.2	17.3	17.4	17.5	17.6	17.7	17.8
	B	-3.1	-1.9	-1.1	0	0.5	0.9	1.4	1.8	2.3	2.7	3.2	3.6	4.1	4.6
Bronze alloys	A	15.1	15.8	16.4	17.2	17.6	17.9	18.0	18.2	18.2	18.3	18.4	18.5	18.5	18.6
	B	-3.3	-1.9	-1.1	0	0.5	1.0	1.4	1.9	2.4	2.8	3.3	3.8	4.3	4.7
Brass alloys	A	14.7	15.4	16.0	16.7	17.1	17.4	17.6	17.8	18.0	18.2	18.4	18.6	18.8	19.0
	B	-3.2	-1.9	-1.1	0	0.5	1.0	1.4	1.9	2.3	2.8	3.3	3.8	4.3	4.8
Copper-nickel (70Cu-30Ni)	A	11.9	13.4	14.0	14.5	14.9	15.2	15.3	15.5	15.7	15.8	16.0	16.1	16.3	16.4
	B	-2.6	-1.6	-1.0	0	0.4	0.8	1.2	1.6	2.0	2.5	2.9	3.3	3.7	4.2
Aluminum alloys	A	18.0	19.7	20.8	21.7	22.6	23.1	23.4	23.7	23.9	24.2	24.4	24.7	25.0	25.2
	B	-4.0	-2.4	-1.5	0	0.7	1.3	1.9	2.5	3.1	3.7	4.4	5.1	5.7	6.4
Titanium alloys (Grades 1, 2, 3, 7, and 12)	A	8.2	8.3	8.4	8.5	8.5	8.6	8.6	8.6	8.7	8.7	8.7	8.8
	B	-0.6	0	0.3	0.5	0.7	0.9	1.1	1.3	1.6	1.8	2.0	2.2

NOTES:

- (1) These data are for information and it is not to be implied that materials are suitable for all the temperature ranges shown.
(2) Group 1 alloys (by nominal composition):

Carbon steels	2 ¹ / ₄ Cr-1Mo
(C, C-Si, C-Mn, and C-Mn-Si)	3Cr-1Mo
C- ¹ / ₂ Mo	¹ / ₂ Ni- ¹ / ₂ Mo-V
¹ / ₂ Cr- ¹ / ₅ Mo-V	¹ / ₂ Ni- ¹ / ₂ Cr- ¹ / ₄ Mo-V
¹ / ₂ Cr- ¹ / ₄ Mo-Si	³ / ₄ Ni- ¹ / ₂ Mo-Cr-V
¹ / ₂ Cr- ¹ / ₂ Mo	³ / ₄ Ni- ¹ / ₂ Mo- ¹ / ₃ Cr-V
¹ / ₂ Cr- ¹ / ₂ Ni- ¹ / ₄ Mo	³ / ₄ Ni- ¹ / ₂ Cu-Mo
³ / ₄ Cr- ¹ / ₂ Ni-Cu	³ / ₄ Ni- ¹ / ₂ Cr- ¹ / ₂ Mo-V
³ / ₄ Cr- ³ / ₄ Ni-Cu-Al	³ / ₄ Ni-1Mo- ³ / ₄ Cr
1Cr- ¹ / ₅ Mo	1Ni- ¹ / ₂ Cr- ¹ / ₂ Mo
1Cr- ¹ / ₅ Mo-Si	1 ¹ / ₄ Ni-1Cr- ¹ / ₂ Mo
1Cr- ¹ / ₂ Mo	1 ³ / ₄ Ni- ³ / ₄ Cr- ¹ / ₄ Mo
1Cr- ¹ / ₂ Mo-V	2Ni- ³ / ₄ Cr- ¹ / ₄ Mo
1 ¹ / ₄ Cr- ¹ / ₂ Mo	2Ni- ³ / ₄ Cr- ¹ / ₃ Mo
1 ¹ / ₄ Cr- ¹ / ₂ Mo-Si	2 ¹ / ₂ Ni
1 ³ / ₄ Cr- ¹ / ₂ Mo-Cu	3 ¹ / ₂ Ni
2Cr- ¹ / ₂ Mo	3 ¹ / ₂ Ni-1 ³ / ₄ Cr- ¹ / ₂ Mo-V

- (3) Group 2 alloys (by nominal composition):

Mn-V
Mn- ¹ / ₄ Mo
Mn- ¹ / ₂ Mo
Mn- ¹ / ₂ Mo- ¹ / ₄ Ni
Mn- ¹ / ₂ Mo- ¹ / ₂ Ni
Mn- ¹ / ₂ Mo- ³ / ₄ Ni

Table B-1 (SI) Thermal Expansion Data (Cont'd)

$A = \text{Mean Coefficient of Thermal Expansion, } 10^{-6} \text{ mm/mm/}^\circ\text{C}$ $B = \text{Linear Thermal Expansion, mm/m}$																				
} in Going From 20°C to Indicated Temperature [Note (1)]																				
Temperature Range 20°C to																				
300	325	350	375	400	425	450	475	500	525	550	575	600	625	650	675	700	725	750	775	800
18.0	18.0
5.0	5.5
18.7	18.8	18.9	19.0	19.0	19.1	19.2	19.3	19.4	19.4	19.5	19.6	19.7	19.7	19.8
5.2	5.7	6.2	6.7	7.2	7.7	8.3	8.8	9.3	9.8	10.3	10.9	11.4	11.9	12.5
19.2	19.3	19.5	19.6	19.8	20.1	20.3	20.5	20.7	20.8	21.0	21.2	21.4	21.6	21.8
5.4	5.9	6.4	7.0	7.5	8.2	8.7	9.3	9.9	10.5	11.1	11.8	12.4	13.1	13.7
16.5	16.5	16.6	16.6	16.7
4.6	5.0	5.5	5.9	6.3
25.5	25.6
7.1	7.8
8.8	8.8	8.9	8.9	9.0	9.2
2.5	2.7	2.9	3.2	3.4	3.7

MANDATORY APPENDIX C

MODULI OF ELASTICITY

Table C-1 Moduli of Elasticity for Ferrous Material

Material	<i>E</i> = Modulus of Elasticity, psi (Multiply Tabulated Values by 10 ⁶) [Note (1)]															
	Temperature, °F															
	-100	70	200	300	400	500	600	700	800	900	1,000	1,100	1,200	1,300	1,400	1,500
Carbon steels with carbon content 0.30% or less	30.3	29.4	28.8	28.3	27.4	27.3	26.5	25.5	24.2	22.5	20.4	18.0
Carbon steels with carbon content above 0.30%	30.1	29.2	28.6	28.1	27.7	27.1	26.4	25.3	24.0	22.3	20.2	17.9	15.4
Carbon–molybdenum steels	30.0	29.0	28.5	28.0	27.6	27.0	26.3	25.3	23.9	22.2	20.1	17.8	15.3
Nickel steels	28.6	27.8	27.1	26.7	26.2	25.7	25.1	24.6	23.9	23.2	22.4	21.5	20.4	19.2	17.7	...
Chromium steels:																
$\frac{1}{2}$ Cr through 2Cr	30.5	29.6	29.0	28.5	28.0	27.4	26.9	26.2	25.6	24.8	23.9	23.0	21.8	20.5	18.9	...
$2\frac{1}{4}$ Cr through 3Cr	31.4	30.6	29.9	29.4	28.8	28.3	27.7	27.0	26.3	25.6	24.7	23.7	22.5	21.1	19.4	...
5Cr through 9Cr	31.9	31.0	30.3	29.7	29.2	28.6	28.1	27.5	26.9	26.2	25.4	24.4	23.3	22.0	20.5	...
Austenitic stainless steels:																
Type 304, 18Cr–8Ni	29.2	28.3	27.5	27.0	26.4	25.9	25.3	24.8	24.1	23.5	22.8	22.0	21.2	20.3	19.2	18.1
Type 310, 25Cr–20Ni	29.2	28.3	27.5	27.0	26.4	25.9	25.3	24.8	24.1	23.5	22.8	22.0	21.2	20.3	19.2	18.1
Type 316, 16Cr–12Ni–2Mo	29.2	28.3	27.5	27.0	26.4	25.9	25.3	24.8	24.1	23.5	22.8	22.0	21.2	20.3	19.2	18.1
Type 321, 18Cr–10Ni–Ti	29.2	28.3	27.5	27.0	26.4	25.9	25.3	24.8	24.1	23.5	22.8	22.0	21.2	20.3	19.2	18.1
Type 347, 18Cr–10Ni–Cb	29.2	28.3	27.5	27.0	26.4	25.9	25.3	24.8	24.1	23.5	22.8	22.0	21.2	20.3	19.2	18.1
Type 309, 23Cr–12Ni	29.2	28.3	27.5	27.0	26.4	25.9	25.3	24.8	24.1	23.5	22.8	22.0	21.2	20.3	19.2	18.1
Straight chromium stainless steels (12Cr, 17Cr, 27Cr)	30.2	29.2	28.4	27.9	27.3	26.8	26.2	25.5	24.5	23.2	21.5	19.2	16.5
Gray cast iron	...	13.4	13.2	12.9	12.6	12.2	11.7	11.0	10.2

NOTE:

(1) These data are for information and it is not to be implied that materials are suitable for all the temperature ranges shown.

Table C-1 (SI) Moduli of Elasticity for Ferrous Material

Material	<i>E</i> = Modulus of Elasticity, MPa (Multiply Tabulated Values by 10 ³) [Note (1)]																
	Temperature, °C																
	-75	25	100	150	200	250	300	350	400	450	500	550	600	650	700	750	800
Carbon steels with carbon content 0.30% or less	209	202	198	195	192	189	185	179	171	162	151	137	122	107
Carbon steels with carbon content above 0.30%	207	201	197	194	191	188	183	178	170	161	149	136	121	106
Carbon-molybdenum steels	207	200	196	193	190	187	183	177	170	160	149	135	121	106
Nickel steels	197	191	187	184	181	178	174	171	167	163	158	153	147	141	133
Chromium steels:																	
$\frac{1}{2}$ Cr through 2Cr	210	204	200	197	193	190	186	183	179	174	169	164	157	150	142
$2\frac{1}{4}$ Cr through 3Cr	217	210	206	202	199	196	192	188	184	180	175	169	162	155	146
5Cr through 9Cr	220	213	208	205	201	198	195	191	187	183	179	174	168	161	153
Austenitic stainless steels:																	
Type 304, 18Cr-8Ni	201	195	189	186	183	179	176	172	169	165	160	156	151	146	140	134	127
Type 310, 25Cr-20Ni	201	195	189	186	183	179	176	172	169	165	160	156	151	146	140	134	127
Type 316, 16Cr-12Ni-2Mo	201	195	189	186	183	179	176	172	169	165	160	156	151	146	140	134	127
Type 321, 18Cr-10Ni-Ti	201	195	189	186	183	179	176	172	169	165	160	156	151	146	140	134	127
Type 347, 18Cr-10Ni-Cb	201	195	189	186	183	179	176	172	169	165	160	156	151	146	140	134	127
Type 309, 23Cr-12Ni	201	195	189	186	183	179	176	172	169	165	160	156	151	146	140	134	127
Straight chromium stainless steels (12Cr, 17Cr, 27Cr)	208	201	195	192	189	186	182	178	173	166	157	145	131
Gray cast iron	...	92	91	89	87	85	82	78	73	67

NOTE:

(1) These data are for information and it is not to be implied that materials are suitable for all the temperature ranges shown.

Table C-2 Moduli of Elasticity for Nonferrous Material

Materials	<i>E</i> = Modulus of Elasticity, psi (Multiply Tabulated Values by 10 ⁶) [Note (1)]												
	Temperature, °F												
	-100	70	200	300	400	500	600	700	800	900	1,000	1,100	1,200
High Nickel Alloys													
N02200 (200)	30.9	30.0	29.4	28.9	28.5	28.1	27.6	27.2	26.7	26.2	25.7	25.1	24.5
N02201 (201)	30.9	30.0	29.4	28.9	28.5	28.1	27.6	27.2	26.7	26.2	25.7	25.1	24.5
N04400 (400)	26.8	26.0	25.5	25.1	24.7	24.3	23.9	23.6	23.1	22.7	22.2	21.7	21.2
N06002 (X)	29.3	28.5	27.9	27.5	27.1	26.7	26.2	25.8	25.4	24.9	24.3	23.8	23.2
N06007 (G)	28.6	27.8	27.2	26.8	26.4	26.0	25.6	25.2	24.7	24.3	23.8	23.2	22.6
N06022	29.3	28.5	27.9	27.5	27.1	26.7	26.2	25.8	25.4	24.9	24.3	23.8	23.2
N06455 (C-4)	30.7	29.8	29.2	28.7	28.3	27.9	27.4	27.0	26.5	26.0	25.5	24.9	24.3
N06600 (600)	31.9	31.0	30.3	29.9	29.4	29.0	28.6	28.1	27.6	27.1	26.5	25.9	25.3
N06617 (617)	...	29.2	28.4	28.0	27.7	27.4	27.0	26.5	26.0	25.5	24.9	24.3	23.8
N06625 (625)	30.9	30.0	29.4	28.9	28.5	28.1	27.6	27.2	26.7	26.2	25.7	25.1	24.5
N08020	28.8	28.0	27.4	27.0	26.6	26.2	25.8	25.4	24.9	24.4	23.9	23.4	22.8
N08320 (20 Mod)	28.6	27.8	27.1	26.7	26.4	26.0	25.7	25.3	24.7	24.2	23.6	23.2	22.7
N08800 (800) (2)	29.3	28.5	27.9	27.5	27.1	26.7	26.2	25.8	25.4	24.9	24.4	23.8	23.2
N08810 (800H) (2)	29.3	28.5	27.9	27.5	27.1	26.7	26.2	25.8	25.4	24.9	24.4	23.8	23.2
N08825	28.8	28.0	27.4	27.0	26.6	26.2	25.8	25.4	24.9	24.4	23.9	23.4	22.8
N10001 (B)	32.0	31.1	30.4	30.0	29.5	29.1	28.7	28.2	27.7	27.2	26.6	26.0	25.3
N10276 (C-276)	30.7	29.8	29.2	28.7	28.3	27.9	27.4	27.0	26.5	26.0	25.5	24.9	24.3
N10665 (B-2)	32.3	31.4	30.7	30.2	29.8	29.3	28.9	28.4	27.9	27.4	26.8	26.2	25.6
Aluminum and Aluminum Alloys													
A24430 (B443)	10.5	10.0	9.6	9.2	8.7	8.1
A91060 (1060)	10.5	10.0	9.6	9.2	8.7	8.1
A91100 (1100)	10.5	10.0	9.6	9.2	8.7	8.1
A93003 (3003)	10.5	10.0	9.6	9.2	8.7	8.1
A93004 (3004)	10.5	10.0	9.6	9.2	8.7	8.1
A96061 (6061)	10.5	10.0	9.6	9.2	8.7	8.1
A96063 (6063)	10.5	10.0	9.6	9.2	8.7	8.1
A95052 (5052)	10.7	10.2	9.7	9.4	8.9	8.3
A95154 (5154)	10.7	10.2	9.7	9.4	8.9	8.3
A95454 (5454)	10.7	10.2	9.7	9.4	8.9	8.3
A95652 (5652)	10.7	10.2	9.7	9.4	8.9	8.3
A03560 (356)	10.8	10.3	9.8	9.5	9.0	8.3
A95083 (5083)	10.8	10.3	9.8	9.5	9.0	8.3
A95086 (5086)	10.8	10.3	9.8	9.5	9.0	8.3
A95456 (5456)	10.8	10.3	9.8	9.5	9.0	8.3
Copper and Copper Alloys													
C83600	14.4	14.0	13.7	13.4	13.2	12.9	12.5	12.0
C92200	14.4	14.0	13.7	13.4	13.2	12.9	12.5	12.0
C46400	15.4	15.0	14.6	14.4	14.1	13.8	13.4	12.8
C65500	15.4	15.0	14.6	14.4	14.1	13.8	13.4	12.8
C95200	15.4	15.0	14.6	14.4	14.1	13.8	13.4	12.8
C95400	15.4	15.0	14.6	14.4	14.1	13.8	13.4	12.8
C10200	17.5	17.0	16.6	16.3	16.0	15.6	15.1	14.5
C11000	17.5	17.0	16.6	16.3	16.0	15.6	15.1	14.5
C12000	17.5	17.0	16.6	16.3	16.0	15.6	15.1	14.5
C12200	17.5	17.0	16.6	16.3	16.0	15.6	15.1	14.5
C12500	17.5	17.0	16.6	16.3	16.0	15.6	15.1	14.5
C14200	17.5	17.0	16.6	16.3	16.0	15.6	15.1	14.5
C23000	17.5	17.0	16.6	16.3	16.0	15.6	15.1	14.5
C61400	17.5	17.0	16.6	16.3	16.0	15.6	15.1	14.5

Table C-2 Moduli of Elasticity for Nonferrous Material (Cont'd)

Materials	$E = \text{Modulus of Elasticity, psi (Multiply Tabulated Values by } 10^6 \text{) [Note (1)]}$												
	Temperature, °F												
	-100	70	200	300	400	500	600	700	800	900	1,000	1,100	1,200
Copper and Copper Alloys (Cont'd)													
C70600	18.5	18.0	17.6	17.3	16.9	16.5	16.0	15.4
C97600	19.6	19.0	18.5	18.2	17.9	17.5	16.9	16.2
C71000	20.6	20.0	19.5	19.2	18.8	18.4	17.8	17.1
C71500	22.6	22.0	21.5	21.1	20.7	20.2	19.6	18.8
Unalloyed Titanium													
Grades 1, 2, 3, 7, and 12	...	15.5	15.0	14.6	14.0	13.3	12.6	11.9	11.2

NOTES:

- (1) These data are for information and it is not to be implied that materials are suitable for all the temperature ranges shown.
- (2) For N08800 and N08810, use the following E values above 1,200°F: at 1,300°F, $E = 22.7$; at 1,400°F, $E = 21.9$; at 1,500°F, $E = 21.2 \times 10^6$ psi.

Table C-2 (SI) Moduli of Elasticity for Nonferrous Material

Materials	<i>E</i> = Modulus of Elasticity, MPa (Multiply Tabulated Values by 10 ³) [Note (1)]																
	Temperature, °C																
	-75	25	100	150	200	250	300	350	400	450	500	550	600	650	700	750	800
High Nickel Alloys																	
N02200 (200)	213	207	202	199	197	194	191	189	186	183	180	176	172	169	164	160	156
N02201 (201)	213	207	202	199	197	194	191	189	186	183	180	176	172	169	164	160	156
N04400 (400)	185	179	175	173	171	168	166	163	161	158	155	152	149	146	142	139	135
N06002 (X)	202	196	192	189	187	184	182	179	176	173	170	167	163	160	156	152	148
N06007 (G)	197	191	187	185	182	180	177	175	172	169	166	163	160	156	152	148	144
N06022	212	206	201	199	196	193	191	188	185	182	179	175	172	168	164	160	155
N06455 (C-4)	212	205	201	198	195	193	190	187	184	181	178	175	171	167	163	159	155
N06600 (600)	220	213	209	206	203	201	198	195	192	189	186	182	178	174	170	165	161
N06617 (617)	...	201	196	193	191	189	187	184	181	178	174	171	167	164	160	156	152
N06625 (625)	213	207	202	199	197	194	191	189	186	183	180	176	172	169	164	160	156
N08020	199	193	189	186	184	181	179	176	173	170	167	164	161	157	153	150	...
N08320 (20 Mod)	198	192	187	185	182	180	177	175	172	169	167	163	159	156	152	149	144
N08800 (800)	202	196	192	189	187	184	182	179	176	173	170	167	164	160	156	152	148
N08810 (800H)	202	196	192	189	187	184	182	179	176	173	170	167	164	160	156	152	148
N08825	199	193	189	186	184	181	179	176	173	170	167	164	161	157	153	150	...
N10001 (B)	221	214	209	206	204	201	198	196	193	189	186	182	178	174	170	166	161
N10276 (C-276)	212	205	201	198	195	193	190	187	184	181	178	175	171	167	163	159	155
N10665 (B-2)	223	216	211	208	206	203	200	197	194	191	188	184	180	176	172	168	163
Aluminum and Aluminum Alloys																	
A24430 (B443)	72	69	66	63	60	57	52	46
A91060 (1060)	72	69	66	63	60	57	52	46
A91100 (1100)	72	69	66	63	60	57	52	46
A93003 (3003)	72	69	66	63	60	57	52	46
A93004 (3004)	72	69	66	63	60	57	52	46
A96061 (6061)	72	69	66	63	60	57	52	46
A96063 (6063)	72	69	66	63	60	57	52	46
A95052 (5052)	74	70	67	65	62	58	53	47
A95154 (5154)	74	70	67	65	62	58	53	47
A95454 (5454)	74	70	67	65	62	58	53	47
A95652 (5652)	74	70	67	65	62	58	53	47
A03560 (356)	75	71	68	65	62	58	54	47
A95083 (5083)	75	71	68	65	62	58	54	47
A95086 (5086)	75	71	68	65	62	58	54	47
A95456 (5456)	75	71	68	65	62	58	54	47
Copper and Copper Alloys																	
C83600	99	96	94	93	91	89	87	84	81
C92200	99	96	94	93	91	89	87	84	81
C46400	106	103	101	99	97	96	93	90	86
C65500	106	103	101	99	97	96	93	90	86
C95200	106	103	101	99	97	96	93	90	86
C95400	106	103	101	99	97	96	93	90	86
C10200	121	117	114	112	110	108	106	102	98
C11000	121	117	114	112	110	108	106	102	98
C12000	121	117	114	112	110	108	106	102	98
C12200	121	117	114	112	110	108	106	102	98
C12500	121	117	114	112	110	108	106	102	98
C14200	121	117	114	112	110	108	106	102	98
C23000	121	117	114	112	110	108	106	102	98
C61400	121	117	114	112	110	108	106	102	98

Table C-2 (SI) Moduli of Elasticity for Nonferrous Material (Cont'd)

Materials	<i>E</i> = Modulus of Elasticity, MPa (Multiply Tabulated Values by 10 ³) [Note (1)]																
	Temperature, °C																
	-75	25	100	150	200	250	300	350	400	450	500	550	600	650	700	750	800
Copper and Copper Alloys (Cont'd)																	
C70600	127	124	121	119	117
C97600	135	131	128	126	123
C71000	142	138	134	132	130
C71500	156	152	148	145	143
Unalloyed Titanium																	
Grades 1, 2, 3, 7, and 12	...	107	103	101	97	93	88	84	80	75	71

NOTE:

(1) These data are for information and it is not to be implied that materials are suitable for all the temperature ranges shown.

MANDATORY APPENDIX D

FLEXIBILITY AND STRESS INTENSIFICATION FACTORS

Table D-1 Flexibility and Stress Intensification Factors

Description	Flexibility Characteristic, h	Flexibility Factor, k	Stress Intensification Factor, i	Sketch
Welding elbow or pipe bend [Notes (1), (2), (3), (4), (5)]	$\frac{t_n R}{r^2}$	$\frac{1.65}{h}$	$\frac{0.9}{h^{2/3}}$	
Closely spaced miter bend [Notes (1), (2), (3), (5)] $s < r(1 + \tan \theta)$ $B \geq 6 t_n$ $\theta \leq 22\frac{1}{2}$ deg	$\frac{s t_n \cot \theta}{2r^2}$	$\frac{1.52}{h^{5/6}}$	$\frac{0.9}{h^{2/3}}$	
Widely spaced miter bend [Notes (1), (2), (5), (6)] $s \geq r(1 + \tan \theta)$ $\theta \leq 22\frac{1}{2}$ deg	$\frac{t_n (1 + \cot \theta)}{2r}$	$\frac{1.52}{h^{5/6}}$	$\frac{0.9}{h^{2/3}}$	
Welding tee per ASME B16.9 [Notes (1), (2), (7)]	$\frac{3.1 t_n}{r}$	1	$\frac{0.9}{h^{2/3}}$	
Reinforced fabricated tee [Notes (1), (2), (8), (9)]	$\frac{\left(t_n + \frac{t_r}{2}\right)^{5/2}}{r (t_n)^{3/2}}$	1	$\frac{0.9}{h^{2/3}}$	
Unreinforced fabricated tee [Notes (1), (2), (9)]	$\frac{t_n}{r}$	1	$\frac{0.9}{h^{2/3}}$	

Table D-1 Flexibility and Stress Intensification Factors (Cont'd)

Description	Flexibility Characteristic, h	Flexibility Factor, k	Stress Intensification Factor, i	Sketch
Branch welded-on fitting (integrally reinforced) per MSS SP-97 [Notes (1), (2)]	$\frac{3.3t_n}{r}$	1	$\frac{0.9}{h^{2/3}}$	
Extruded outlet meeting the requirements of para. 104.3.1(G) [Notes (1), (2)]	$\frac{t_n}{r}$	1	$\frac{0.9}{h^{2/3}}$	
Welded-in contour insert [Notes (1), (2), (7)]	$3.1 \frac{t_n}{r}$	1	$\frac{0.9}{h^{2/3}}$	
Description	Flexibility Factor, k	Stress Intensification Factor, i		Sketch
Branch connection [Notes (1), (10)]	1	For checking branch end $1.5 \left(\frac{R_m}{t_{nh}}\right)^{2/3} \left(\frac{r'_m}{R_m}\right)^{1/2} \left(\frac{t_{nb}}{t_{nh}}\right) \left(\frac{r'_m}{r_p}\right)$		See Fig. D-1
Butt weld [Note (1)]				
$t \geq 0.237$ in., $\delta_{max} \leq \frac{1}{16}$ in., and $\delta_{avg}/t \leq 0.13$	1	1.0 [Note (11)]		
Butt weld [Note (1)]				
$t \geq 0.237$ in., $\delta_{max} \leq \frac{1}{8}$ in., and $\delta_{avg}/t =$ any value	1	1.9 max. or $[0.9 + 2.7(\delta_{avg}/t)]$, but not less than 1.0 [Note (11)]		
Butt weld [Note (1)]				
$t < 0.237$ in., $\delta_{max} \leq \frac{1}{16}$ in., and $\delta_{avg}/t \leq 0.33$	1	1.0		
Fillet welds	1	1.3 [Note (12)]		See Figs. 127.4.4(A), 127.4.4(B), and 127.4.4(C)
Tapered transition per para. 127.4.2(B) and ASME B16.25 [Note (1)]	1	1.9 max. or $1.3 + 0.0036 \frac{D_o}{t_n} + 3.6 \frac{\delta}{t_n}$		

Table D-1 Flexibility and Stress Intensification Factors (Cont'd)

Description	Flexibility Factor, k	Stress Intensification Factor, i	Sketch
Concentric reducer per ASME B16.9 [Notes (1), (13)]	1	2.0 max. or $0.5 + 0.01\alpha \left(\frac{D_2}{t_2}\right)^{1/2}$	
Threaded pipe joint or threaded flange	1	2.3	...
Corrugated straight pipe, or corrugated or creased bend [Note (14)]	5	2.5	...

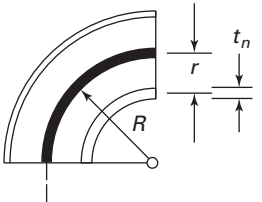
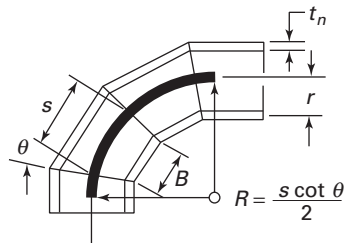
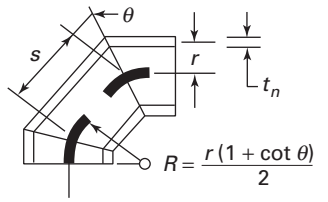
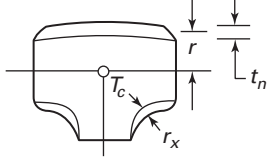
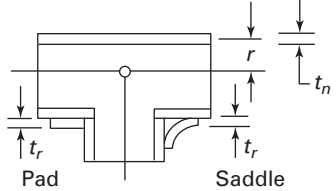
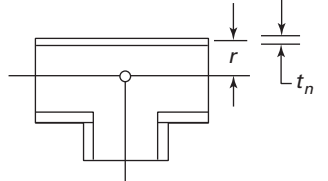
GENERAL NOTE: The validity of the stress intensification and flexibility factor data in Table D-1 has been demonstrated for $D_o/t_n \leq 100$.

NOTES:

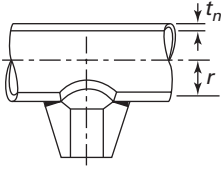
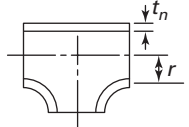
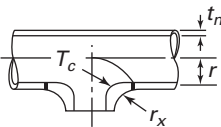
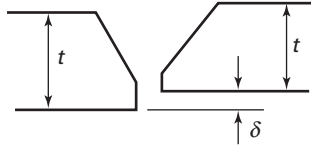
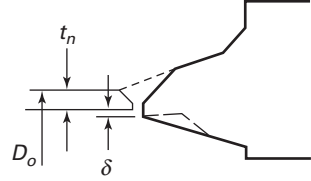
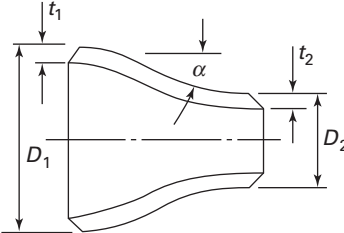
- The following nomenclature applies to Table D-1:
 - B = length of miter segment at crotch, in. (mm)
 - D_o = outside diameter, in. (mm)
 - D_{ob} = outside diameter of branch, in. (mm)
 - D_1 = outside diameter of reducer on large end, in. (mm)
 - D_2 = outside diameter of reducer on small end, in. (mm)
 - R = bend radius of elbow or pipe bend, in. (mm)
 - r = mean radius of pipe, in. (mm) (matching pipe for tees)
 - r_x = external crotch radius of welded-in contour inserts and welding tees, in. (mm)
 - s = miter spacing at centerline, in. (mm)
 - T_c = crotch thickness of welded-in contour inserts and welding tees, in. (mm)
 - t_n = nominal wall thickness of pipe, in. (mm) (matching pipe for tees)
 - t_r = reinforcement pad or saddle thickness, in. (mm)
 - α = reducer cone angle, deg
 - δ = mismatch, in. (mm)
 - θ = one-half angle between adjacent miter axes, deg
- The flexibility factors k and stress intensification factors i in Table D-1 apply to bending in any plane for fittings and shall in no case be taken less than unity. Both factors apply over the effective arc length (shown by heavy centerlines in the sketches) for curved and miter elbows, and to the intersection point for tees. The values of k and i can be read directly from Chart D-1 by entering with the characteristic h computed from the formulas given.
- Where flanges are attached to one or both ends, the values of k and i in Table D-1 shall be multiplied by the factor c given below, which can be read directly from Chart D-2, entering with the computed h : one end flanged, $c = h^{1/6}$; both ends flanged, $c = h^{1/3}$.
- The designer is cautioned that cast butt welding elbows may have considerably heavier walls than those of the pipe with which they are used. Large errors may be introduced unless the effect of these greater thicknesses is considered.
- In large diameter thin-wall elbows and bends, pressure can significantly affect magnitudes of k and i . Values from the Table may be corrected by dividing k by

$$\left[1 + 6 \left(\frac{P}{E_c} \right) \left(\frac{r}{t_n} \right)^{7/3} \left(\frac{R}{r} \right)^{1/3} \right]$$

and dividing i by

$$\left[1 + 3.25 \left(\frac{P}{E_c} \right) \left(\frac{r}{t_n} \right)^{5/2} \left(\frac{R}{r} \right)^{2/3} \right]$$

- Also includes single miter joints.
- If $r_x \geq D_{ob}/8$ and $T_c \geq 1.5t_n$, a flexibility characteristic, h , of $4.4t_n/r$ may be used.
- When $t_r > 1.5t_n$, $h = 4.05t_n/r$.
- The stress intensification factors in the Table were obtained from tests on full size outlet connections. For less than full size outlets, the full size values should be used until more applicable values are developed.

Table D-1 Flexibility and Stress Intensification Factors (Cont'd)

NOTES (Cont'd):

- (10) The equation applies only if the following conditions are met:
- (a) The reinforcement area requirements of para. 104.3 are met.
 - (b) The axis of the branch pipe is normal to the surface of run pipe wall.
 - (c) For branch connections in a pipe, the arc distance measured between the centers of adjacent branches along the surface of the run pipe is not less than three times the sum of their inside radii in the longitudinal direction or is not less than two times the sum of their radii along the circumference of the run pipe.
 - (d) The inside corner radius r_1 (see Fig. D-1) is between 10% and 50% of t_{nh} .
 - (e) The outer radius r_2 (see Fig. D-1) is not less than the larger of $T_b/2$, $(T_b + y)/2$ [shown in Fig. D-1 sketch (c)], or $t_{nh}/2$.
 - (f) The outer radius r_3 (see Fig. D-1) is not less than the larger of:
 - (1) $0.002\theta d_o$;
 - (2) $2(\sin \theta)^3$ times the offset for the configurations shown in Fig. D-1 sketches (a) and (b).
 - (g) $R_m/t_{nh} \leq 50$ and $r'_m/R_m \leq 0.5$.
- (11) The stress intensification factors apply to girth butt welds between two items for which the wall thicknesses are between $0.875t$ and $1.10t$ for an axial distance of $\sqrt{D_o t}$. D_o and t are nominal outside diameter and nominal wall thickness, respectively. δ_{avg} is the average mismatch or offset.
- (12) For welds to socket welded fittings, the stress intensification factor is based on the assumption that the pipe and fitting are matched in accordance with ASME B16.11 and a full weld is made between the pipe and fitting as shown in Fig. 127.4.4(C). For welds to socket welding flanges, the stress intensification factor is based on the weld geometry shown in Fig. 127.4.4(B) and has been shown to envelop the results of the pipe to socket welded fitting tests. Blending the toe of the fillet weld, with no undercut, smoothly into the pipe wall, as shown in the concave fillet welds in Fig. 127.4.4(A) sketches (b) and (d), has been shown to improve the fatigue performance of the weld.
- (13) The equation applies only if the following conditions are met:
- (a) Cone angle α does not exceed 60 deg, and the reducer is concentric.
 - (b) The larger of D_1/t_1 and D_2/t_2 does not exceed 100.
 - (c) The wall thickness is not less than t_1 throughout the body of the reducer, except in and immediately adjacent to the cylindrical portion on the small end, where the thickness shall not be less than t_2 .
- (14) Factors shown apply to bending; flexibility factor for torsion equals 0.9.

Fig. D-1 Branch Connection Dimensions

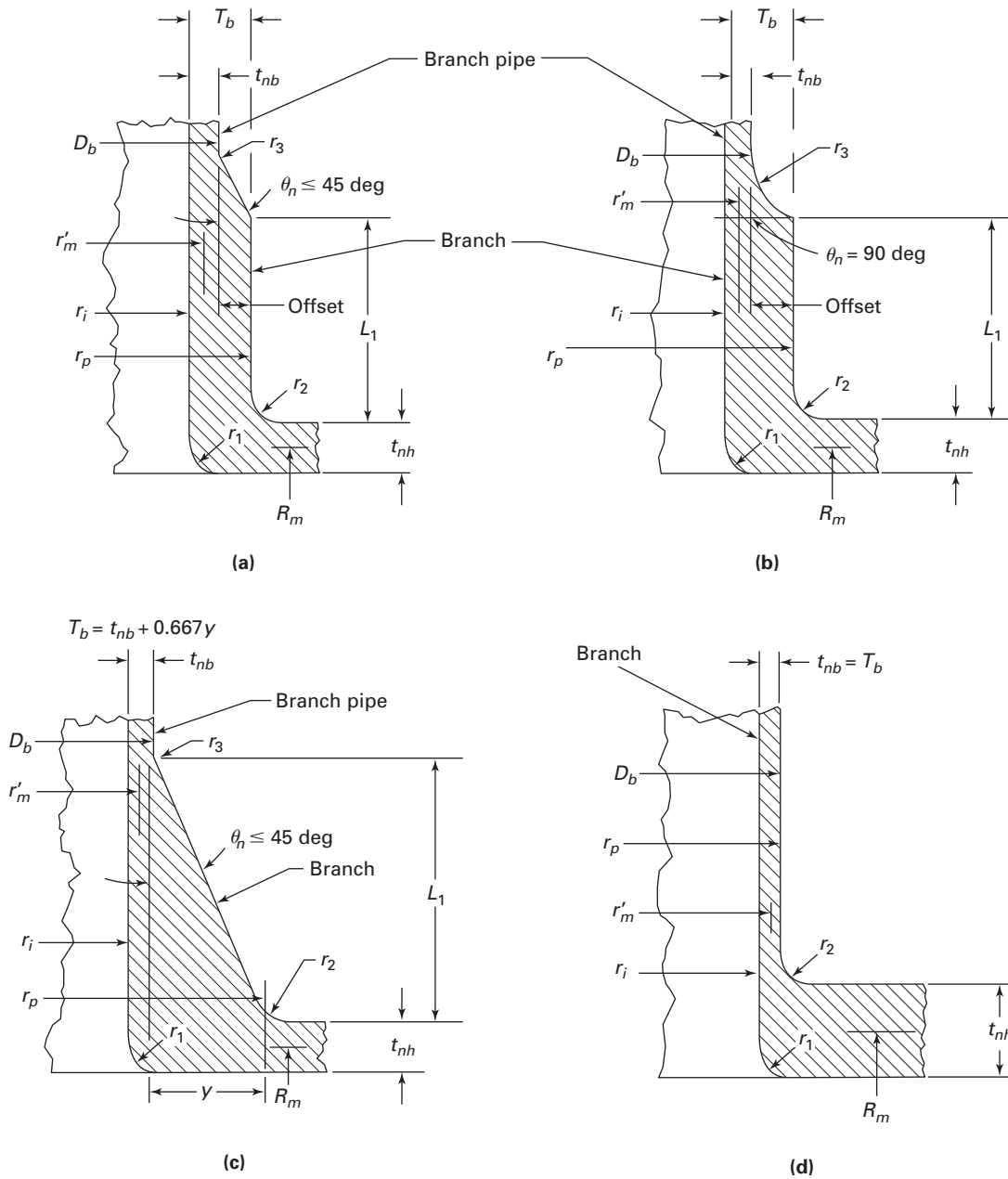

D_b = outside diameter of branch pipe, in. (mm)
 L_1 = height of nozzle, in. (mm)
 R_m = mean radius of run pipe, in. (mm)
 T_b = effective thickness of branch reinforcement, in. (mm)
 r_i = inside radius of branch, in. (mm)
 r'_m = mean radius of branch pipe, in. (mm)

r_1, r_2, r_3 = transition radii of branch reinforcement, in. (mm)
 r_p = outside radius of branch reinforcement, in. (mm)
 t_{nb} = nominal thickness of branch pipes, in. (mm)
 t_{nh} = nominal thickness of run pipe, in. (mm)
 θ_n = transition angle of branch reinforcement, deg

Chart D-1 Flexibility Factor, k , and Stress Intensification Factor, i

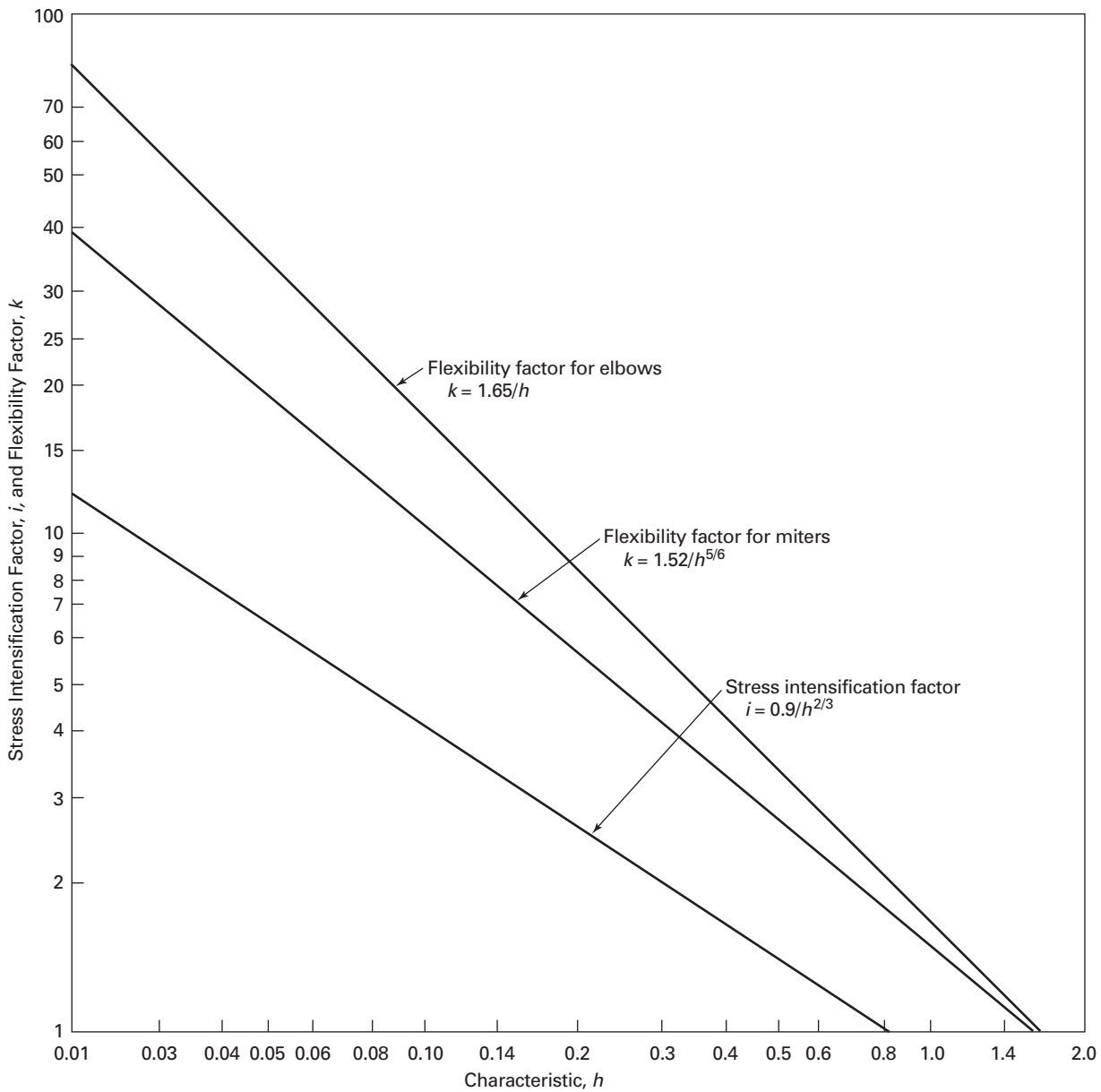
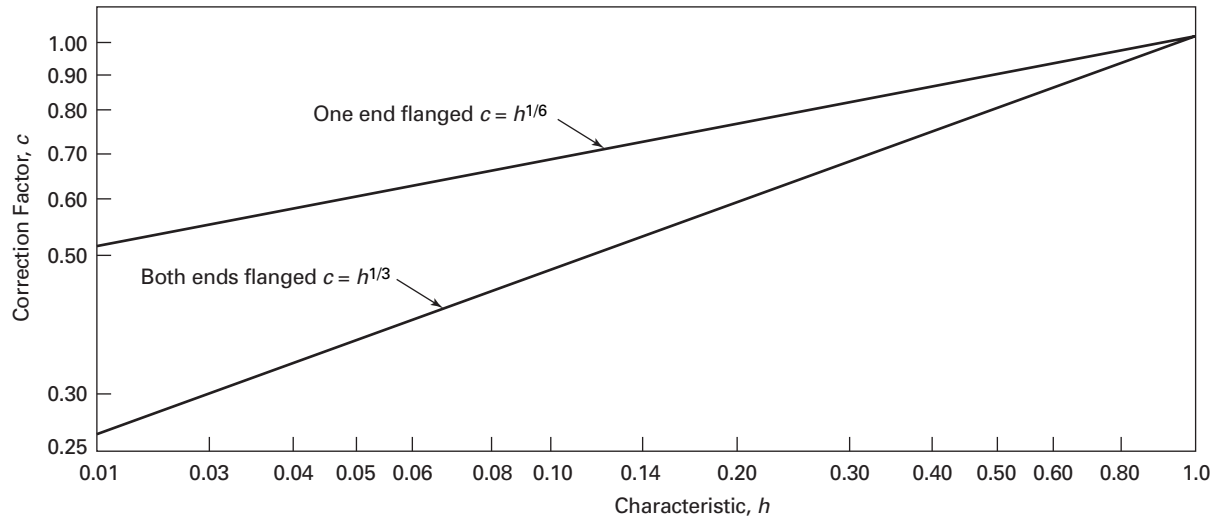

Chart D-2 Correction Factor, c



MANDATORY APPENDIX F REFERENCED STANDARDS

(16)

Specific editions of standards incorporated in this Code by reference are shown in this issue of Mandatory Appendix F. It is not practical to refer to a specific edition of each standard throughout the Code text, but instead, the specific edition reference dates are shown here. Mandatory Appendix F will be revised at intervals as needed and issued. The names and addresses of the sponsoring organizations are also shown in this issue.

American National Standard	ASTM Specifications [Note (1)] (Cont'd)	ASTM Specifications [Note (1)] (Cont'd)
Z223.1-2012		
ASCE/SEI Standard		
7-05, 7-10	A307-07b A312/A312M-13b A320/A320M-07a A322-07 A333/A333M-05 A335/A335M-06 A336/A336M-07 A350/A350M-04a A351/A351M-06 A354-07 A358/A358M-05 A369/A369M-06 A376/A376M-06 A377-03 A387/A387M-06a A389/A389M-03 A395/A395M-99 (R04)	A815/A815M-07a A928/A928M-11 A965/A965M-12 A992/A992M-06a B26/B26M-05 B32-04 B42-02 B43-98 (R04) B61-02 B62-02 B68-02 B68M-99 (R05) B75-02 B88-03 B88M-05
ASTM Specifications [Note (1)]		
A36/A36M-05 A47/A47M-99 (R04) A48/A48M-03 A53/A53M-07 A105/A105M-05 A106/A106M-10 A125-96 (R07) A126-04 A134-96 (R05) A135/A135M-06 A139/A139M-04 A178/A178M-02 A179/A179M-90a (R05) A181/A181M-06 A182/A182M-07a A192/A192M-02 A193/A193M-07 A194/A194M-07a A197/A197M-00 (R06) A210/A210M-02 A213/A213M-07a A214/A214M-96 (R05) A216/A216M-07 A217/A217M-07 A229/A229M-99 A234/A234M-07 A240/A240M-11b A242/A242M-04 ^{e1} A249/A249M-07 A254-97 (R02) A268/A268M-05a A276-06 A278/A278M-01 (R06) A283/A283M-00 A285/A285M-03 A299/A299M-04	A403/A403M-13a A409/A409M-01 (R05) A420/A420M-07 A426/A426M-07 A437/A437M-06 A449-07b A450/A450M-04a A451/A451M-06 A453/A453M-04 A479/A479M-11 A515/A515M-03 A516/A516M-06 A530/A530M-04a A564/A564M-04 A575-96 (R02) A576-90b (R06) A587-96 (R05) A671-06 A672-06 A691-98 (R02) A714-99 (R03) A789/A789M-11 A790/A790M-11	B108-06 B111/B111M-04 B148-97 B150/B150M-03 B151/B151M-05 B161-05 B163-04 B165-05 B166-08 B167-11 B168-08 B171-04 B209/B209M-06 B210-04 B210M-05 B221-06 B234-04 B234M-04 B241/B241M-02 B247-02a B247M-02a B251-02 ^{e1} B251M-97 (R03) B265-07 B280-03 B283-06

Referenced Standards (Cont'd)

ASTM Specifications [Note (1)]
(Cont'd)

B302-07
 B315-06
 B338-06a
 B348-06a
 B361-02
 B366-04b^{e1}
 B367-06
 B381-06a

 B407-04
 B408-06
 B409-06^{e1}
 B423-05
 B424-05
 B425-99 (R05)
 B435-06
 B443-00 (R05)
 B444-06
 B446-03 (R08)
 B462-06
 B463-04
 B464-05
 B466/B466M-07
 B467-88 (R03)
 B468-04
 B473-07

 B546-04
 B547/B547M-02
 B564-06a
 B572-06
 B574-06^{e1}
 B575-06
 B584-06a

 B608-07
 B619-06
 B622-06
 B625-05
 B626-06
 B649-06
 B673-05^{e1}
 B674-05
 B675-02
 B676-03
 B677-05
 B688-96 (R04)
 B690-02 (R07)
 B691-95

 B704-03
 B705-05
 B729-05

ASTM Specifications [Note (1)]
(Cont'd)

B804-02
 B828-02
 B861-06a
 B862-06b^{e1}

ASTM Standard Test Methods

D323-06
 E94-04
 E125-85 (R04)
 E186-04
 E280-04
 E446-04

MSS Standard Practices

SP-6-12
 SP-9-13
 SP-25-13
 SP-42-13
 SP-43-13
 SP-45-03 (R08)
 SP-51-12
 SP-53-99 (R07)
 SP-54-99 (R07)
 SP-55-06
 SP-58-09
 SP-61-13
 SP-67-11
 SP-68-11
 SP-75-14
 SP-79-11
 SP-80-13
 SP-83-14
 SP-88-10
 SP-93-99 (R04)
 SP-94-92
 SP-95-14
 SP-97-12
 SP-105-10
 SP-106-12

AWS Specifications

A3.0-01
 D10.10-99
 QC1-07

API Specifications

5L, 38th Edition, 1990
 570, 3rd Edition, 2009

ASME Codes & Standards

Boiler and Pressure Vessel Code,
 2001 Edition, including
 Addenda

B1.1-1989
 B1.13M-2001
 B1.20.1-1983 (R2001)
 (ANSI/ASME B1.20.1)
 B1.20.3-1976 (R1998)
 (ANSI B1.20.3)
 B16.1-2005
 B16.3-1998
 B16.4-2005
 B16.5-2003
 B16.9-2001
 B16.10-2000
 B16.11-2005
 B16.14-1991
 B16.15-1985 (R1994)
 (ANSI/ASME B16.15)
 B16.18-1984 (R1994)
 (ANSI B16.18)
 B16.20-1998
 B16.21-2005
 B16.22-2001 (R2005)
 B16.24-2001
 B16.25-2003
 B16.26-2011
 B16.34-2004
 B16.42-1998
 B16.47-1996 (1998a)
 B16.48-2005
 B16.50-2001

 B18.2.1-1996 (1999a)
 B18.2.2-1987 (R1999)
 (ASME/ANSI B18.2.2)
 B18.2.3.5M-1979 (R2001)
 B18.2.3.6M-1979 (R2001)
 B18.2.4.6M-1979 (R1998)
 B18.21.1-1999
 B18.22M-1981
 B18.22.1-1965 (R1998)

B31.3-2002
 B31.4-2002
 B31.8-1999
 B31Ea-2010
 B31J-2008 (R2013)
 B31T-2010
 B36.10M-2004
 B36.19M-2004

 TDP-1-1998

Referenced Standards (Cont'd)

AWWA and ANSI/AWWA Standards	AWWA and ANSI/AWWA Standards (Cont'd)	National Fire Codes
C110/A21.10-98	C300-97	NFPA 85-11
C111/A21.11-95	C301-99	NFPA 1963-09
C115/A21.15-99	C302-95	PFI Standards
C150/A21.50-96	C304-99	ES-16-08
C151/A21.51-96	C500-93(95a)	ES-24-08
C153/A21.53-94	C504-94	FCI Standard
C200-97	C509-94	79-1-03
C207-94	C600-99	
C208-96	C606-97	

GENERAL NOTE: The issue date shown immediately following the hyphen after the number of the standard (e.g., B1.1-1989, A36/A36M-05, SP-6-12) is the effective date of issue (edition) of the standard. B18.2.2-1987 (R1999) designates specification reaffirmed without change in 1999.

NOTE:

(1) For boiler external piping material application, see para. 123.2.2.

Specifications and standards of the following organizations appear in this Appendix:

AISC	American Institute of Steel Construction 1 East Wacker Drive, Suite 700 Chicago, IL 60601-1802 Phone: 312 670-2400 Fax: 312 670-5403 www.aisc.org	ASTM	American Society for Testing and Materials (ASTM International) 100 Barr Harbor Drive P.O. Box C700 West Conshohocken, PA 19428-2959 Phone: 610 832-9585 Fax: 610 832-9555 www.astm.org
ANSI	American National Standards Institute 25 West 43rd Street New York, NY 10036 Phone: 212 642-4900 Fax: 212 398-0023 www.ansi.org	AWS	American Welding Society 8669 NW 36 Street, No. 130 Miami, FL 33166 Phone: 305 443-9353 or 800 443-9353 www.aws.org
API	American Petroleum Institute 1220 L Street, NW Washington, DC 20005-4070 Phone: 202 682-8000 www.api.org	AWWA	American Water Works Association 6666 West Quincy Avenue Denver, CO 80235 Phone: 303 794-7711 or 800 926-7337 www.awwa.org
ASCE	American Society of Civil Engineers 1801 Alexander Bell Drive Reston, VA 20191-4400 Phone: 800 548-2723 703 295-6300 (International) Fax: 703 295-6222 www.asce.org	FCI	Fluid Controls Institute, Inc. 1300 Sumner Avenue Cleveland, OH 44115-2851 Phone: 216 241-7333 Fax: 216 241-0105 www.fluidcontrolsinstitute.org
ASME	The American Society of Mechanical Engineers Two Park Avenue New York, NY 10016-5990 Phone: 800-843-2763 Fax: 973 882-1717, 5155 www.asme.org	MSS	Manufacturers Standardization Society of the Valve and Fittings Industry, Inc. 127 Park Street, NE Vienna, VA 22180-4602 Phone: 703 281-6613 www.msshq.org

Referenced Standards (Cont'd)

NFPA	National Fire Protection Association 1 Batterymarch Park Quincy, MA 02169-7471 Phone: 617 770-3000 or 800-344-3555 Fax: 617 770-0700 www.nfpa.org	PPI	Plastics Pipe Institute 105 Decker Court, Suite 825 Irving, TX 75062 Phone: 469 499-1044 Fax: 469 499-1063 www.plasticpipe.org
PFI	Pipe Fabrication Institute USA Office: 511 Avenue of the Americas, #601 New York, NY 10011 Canada Office: 655-32nd Ave., #201 Lachine, QC H8T 3G6 Phone: 514 634-3434 or 866 913-3434 Fax: 514 634-9736 www.pfi-institute.org	SEI	Structural Engineering Institute of ASCE 1801 Alexander Bell Drive Reston, VA 20191-4400 Phone: 800 548-2723 Fax: 703 295-6361 www.seinstitute.org

MANDATORY APPENDIX G NOMENCLATURE

(16)

This Appendix is a compilation of the nomenclature used within this Code. Included are the term definitions and units that can be uniformly applied. These terms are also defined at a convenient location within the Code. When used elsewhere within the Code, definitions given here shall be understood to apply.

Symbol	Definition	Units		References	
		SI	U.S.	Paragraph	Table/Fig./App.
<i>A</i>	Corrosion, erosion, and mechanical allowances (including threading, grooving)	mm	in.	104.1.2(A)[eqs. (3), (4), (7), (8), (9), (10)] 104.3.1(D.2) 104.3.1(G) 104.4.1(B) 104.5.2(B)[eq. (13)] 104.5.3(A)	104.3.1(G)
Area available for reinforcement:					
<i>A</i> ₁	in run pipe	mm ²	in. ²	104.3.1(D.2.3) 104.3.1(G.6)	104.3.1(D) 104.3.1(G)
<i>A</i> ₂	in branch pipe	mm ²	in. ²	104.3.1(D.2.3) 104.3.1(G.6)	104.3.1(D) 104.3.1(G)
<i>A</i> ₃	by deposited metal beyond outside diameter of run and branch and for fillet weld attachments of rings, pads, and saddles	mm ²	in. ²	104.3.1(D.2.3)	104.3.1(D)
<i>A</i> ₄	by reinforcing ring, pad, or integral reinforcement	mm ²	in. ²	104.3.1(D.2.3) 104.3.1(G.6)	104.3.1(D) 104.3.1(G)
<i>A</i> ₅	in saddle on right angle connection	mm ²	in. ²	104.3.1(D.2.3)	104.3.1(D)
<i>A</i> ₆	Pressure design area expected at the end of service life	mm ²	in. ²	104.3.1(D.2)	104.3.1(D)
<i>A</i> ₇	Required reinforcement area	mm ²	in. ²	104.3.1(D.2.2) 104.3.1(G.5)	104.3.1(D) 104.3.1(G)
<i>B</i>	Length of miter segment at crotch	mm	in.	104.3.3(A&B)	App. D, Table D-1
<i>b</i>	Subscript referring to branch	104.3.1(D.2)	104.3.1(D)
<i>C</i>	Cold-spring factor	119.10.1[eqs. (18), (19)]	...
<i>C</i> _x	Size of fillet weld for socket welding components other than flanges	mm	in.	...	127.4.4(C)
<i>c</i>	Flanged elbow correction factor	Table D-1 Chart D-2
<i>D</i>	Nominal pipe size	mm	in.	119.7.1(A.3)	...
<i>D</i> _{1,2}	Outside diameter of reducer	mm	in.	...	App. D, Table D-1

Symbol	Definition	Units		References	
		SI	U.S.	Paragraph	Table/Fig./App.
D_o	Outside diameter of pipe	mm	in.	102.3.2(A) 104.1.2(A)[eqs. (7), (9)] 104.8.1[eq. (15)] 104.8.2[eq. (16)]	App. D, Table D-1 104.1.2(A)
D_{ob}	Outside diameter of branch	mm	in.	104.3.1(D.2) 104.3.1(D.2.3) 104.3.1(E) 104.3.1(G.4) 104.3.1(G.5)	App. D, Fig. D-1 104.3.1(G)
D_{oh}	Outside diameter of header or run pipe	mm	in.	104.3.1(D.2) 104.3.1(E) 104.3.1(G.4) 104.3.1(G.5)	104.3.1(G)
d	Inside diameter of pipe	mm	in.	104.1.2(A)[eqs. (8), (10)]	104.1.2(A)
d_1	Inside centerline longitudinal direction of the finished branch opening in the run of the pipe	mm	in.	104.3.1(D) 104.3.1(E)	104.3.1(D)
d_2	Half-width of reinforcement zone	mm	in.	104.3.1(D.2)	104.3.1(D)
d_5	Diameter of finished opening	mm	in.	104.4.2	...
d_6	Inside or pitch diameter of gasket	mm	in.	104.5.3(A)[eq. (14)]	104.5.3
d_b	Corroded internal diameter of branch pipe	mm	in.	104.3.1(G.4)	104.3.1(G)
d_c	Corroded internal diameter of extruded outlet	mm	in.	104.3.1(G.4) 104.3.1(G.5) 104.3.1(G.6)	104.3.1(G)
d_i	Inside diameter of Y-globe valve	mm	in.	...	122.1.7(C)
d_n	Nominal inside diameter of pipe	mm	in.	102.3.2(A)	...
d_r	Corroded internal diameter of run	mm	in.	104.3.1(G.4)	104.3.1(G)
E	Weld joint efficiency factor	104.1.2(A.5)	102.4.3 App. A Notes and Tables
E	Young's modulus of elasticity (used with subscripts)	MPa	psi	119.6.2 119.6.4 119.10.1[eqs. (18), (19)]	App. C, Tables C-1 and C-2 App. D, Table D-1
F	Casting quality factor	104.1.2(A.5)	App. A Notes and Tables
f	Stress range reduction factor	102.3.2(B)[eq. (1)]	...
h	Subscript referring to run or header	104.3.1(D.2)	104.3.1(D) 104.3.1(G)
h	Thread depth (ref. ASME B1.20.1)	mm	in.	102.4.2	...
h	Flexibility characteristic, to compute i , k	App. D, Table D-1

Symbol	Definition	Units		References	
		SI	U.S.	Paragraph	Table/Fig./App.
h_o	Height of extruded lip	mm	in.	104.3.1(G.2) 104.3.1(G.4)	104.3.1(G)
l	Lorenz equation compensation factor	102.4.5[eqs. (3), (4), (5), (6)]	...
i	Stress intensification factor	104.8.1[eq. (15)] 104.8.2[eq. (16)] 104.8.3[eq. (17)] 104.8.4(C)	App. D, Table D-1
j	Subscript for resultant moment	104.8.4(A)	...
K	Factor for reinforcing area	104.3.1(G.5)	104.3.1(G)
k	Factor for occasional loads	104.8.2[eq. (16)]	...
k	Flexibility factor	App. D, Table D-1
L	Developed length of line axis	m	ft	119.7.1(A.3)	...
L_1	Height of nozzle	mm	in.	104.8.4(C)	App. D, Fig. D-1
L_4	Altitude of reinforcing zone outside run pipe	mm	in.	104.3.1(D.2)	104.3.1(D)
L_8	Altitude of reinforcing zone for extruded outlet	mm	in.	104.3.1(G.4) 104.3.1(G.6)	104.3.1(G)
M	Moment of bending or torsional force (used with subscripts to define applications as shown in referenced paragraphs)	mm·N	in.-lb	104.8.1[eq. (15)] 104.8.2[eq. (16)] 104.8.3[eq. (17)] 104.8.4(A) 104.8.4(C)	104.8.4
MAWP	Maximum allowable working pressure	kPa	psi	100.2	...
MSOP	Maximum sustained operating pressure	kPa	psi	101.2.2	...
N	Total number of equivalent reference displacement stress range cycles	102.3.2(B)[eq. (2)]	...
N_E	Number of cycles of reference displacement stress range	102.3.2(B)[eq. (2)]	...
N_i	Number of cycles associated with displacement stress range	102.3.2(B)[eq. (2)]	...
NPS	Nominal pipe size	...	in.	General	...

Symbol	Definition	Units		References	
		SI	U.S.	Paragraph	Table/Fig./App.
P	Internal design gage pressure of pipe, component	kPa	psi	102.3.2(A) 104.1.2(A)[eqs. (7), (8), (9), (10)] 104.5.1(A) 104.5.2(B) 104.5.3(A)[eq. (14)] 104.5.3(B) 104.8.1[eq. (15)] 104.8.2[eq. (16)] 122.1.2(A) 122.1.3(A) 122.1.4(A) 122.1.4(B) 122.1.6(B) 122.1.7(C) 122.4(B)	App. D, Table D-1
q_i	Ratio of computed stress range other than reference range (S_i) to computed reference stress range (S_E)	102.3.2(B)[eq. (2)]	...
R	Reaction moment in flexibility analysis (used with subscripts)	mm-N	in.-lb	119.10.1[eqs. (18), (19)]	...
R	Centerline radius of elbow or bend, and effective "radius" of miter bends	mm	in.	102.4.5(B) 104.3.3(C.3.1) 129.3.4.1	App. D, Table D-1 102.4.5
R_f	Mean radius after forming	mm	in.	129.3.4.1	...
R_g	Original mean radius	mm	in.	129.3.4.1	...
R_m	Mean radius of run pipe	mm	in.	...	App. D, Fig. D-1 App. D, Table D-1
r	Mean radius of pipe using nominal wall t_n	mm	in.	104.3.3	App. D, Table D-1
r_1	Half width of reinforcement zone	mm	in.	104.3.1(G.4)	104.3.1(G)
r_1, r_2, r_3	Transition radii of branch reinforcement	mm	in.	...	App. D, Fig. D-1
r_b	Branch mean cross-sectional radius	mm	in.	104.8.4	...
r_i	Inside radius of branch	mm	in.	104.8.4(C)	App. D, Fig. D-1
r'_m	Mean radius of branch	mm	in.	104.8.4(C)	App. D, Fig. D-1 App. D, Table D-1
r_o	Radius of curvature of external curved portion	mm	in.	104.3.1(G.2) 104.3.1(G.4) 104.3.1(G.6)	104.3.1(G)
r_{od}	Normal outside radius of pipe or tube	mm	in.	129.3.4.1	...
r_p	Outside radius of branch reinforcement	mm	in.	...	App. D, Fig. D-1 App. D, Table D-1
r_x	External crotch radius of welded-in contour inserts	mm	in.	...	App. D

Symbol	Definition	Units		References	
		SI	U.S.	Paragraph	Table/Fig./App.
S	Basic material allowable stress	MPa	psi	122.1.2(A) 122.1.3(B) 122.4(B.3)	...
S	Basic material allowable stress	MPa	ksi	102.3.1(A)	App. A Tables and Notes
S_a	Bolt design stress at atmospheric temperature	kPa	psi	104.5.1(A)	...
S_b	Bolt design stress at design temperature	kPa	psi	104.5.1(A)	...
S_c	Basic material allowable stress at minimum (cold) temperature	MPa	psi	102.3.2(B)[eq. (1)]	...
S_f	Allowable stress for flange material or pipe	kPa	psi	104.5.1(A)	...
S_h	Basic material allowable stress at maximum (hot) temperature	MPa	psi	102.3.2(B)[eq. (1)] 104.8.1[eq. (15)] 104.8.2[eq. (16)] 104.8.3[eq. (17)] 119.10.1 [eq. (19)]	...
S_{lp}	Longitudinal pressure stress	kPa	psi	102.3.2(A) 104.8	...
S_A	Allowable stress range for expansion stress	MPa	psi	102.3.2(B)[eq. (1)] 104.8.3[eq. (17)]	...
S_E	Computed thermal expansion stress range	MPa	psi	104.8.3[eq. (17)] 119.6.4 119.10.1[eq. (19)]	...
S_L	Longitudinal stress due to pressure, weight, and other sustained loads	MPa	psi	102.3.2(D) 104.8.1[eq. (15)]	...
SE	Allowable stress (including weld joint efficiency factor)	MPa	psi	102.3.2(B) 104.1.2(A)[eqs. (7), (8), (9), (10)] 104.5.2(B) 104.5.3(A)[eq. (14)] 104.5.3(B)	...
SE	Allowable stress (including weld joint efficiency factor)	MPa	ksi	102.3.1(A)	App. A Tables and Notes
SF	Allowable stress (including casting quality factor)	MPa	psi	104.1.2(A)	...
SF	Allowable stress (including casting quality factor)	MPa	ksi	102.3.1(A)	App. A Tables and Notes
s	Miter spacing pipe centerline	mm	in.	...	App. D, Table D-1
T	Actual pipe wall thickness (by measurement) or the minimum wall thickness permissible under the purchase specification, used with or without subscripts, namely T_b = thickness of branch T_h = thickness of header, etc.	mm	in.	104.3.1(D.2) 104.3.1(G.4) 104.3.1(G.6) 104.8.4(C)	104.3.1(D) 104.3.1(G) App. D, Fig. D-1
T_c	Crotch thickness of welded-in contour inserts	mm	in.	...	App. D, Table D-1

Symbol	Definition	Units		References	
		SI	U.S.	Paragraph	Table/Fig./App.
t_o	Corroded finished thickness extruded outlet	mm	in.	104.3.1(G.4) 104.3.1(G.6)	104.3.1(G)
t	Pressure design thickness pipe, components (used with subscripts)	mm	in.	104.1.2(A)[eqs. (7), (8), (9), (10)] 104.3.1(D.2) 104.3.1(G.4) 104.3.3(C.3.1) 104.3.3(C.3.2) 104.4.1(B) 104.4.2 104.5.2(B)[eq. (13)] 104.5.3(A)[eq. (14)] 104.5.3(B) 104.8.1 104.8.4(C) 127.4.8(B) 132.4.2(E)	104.3.1(G) 104.5.3 127.4.8(D)
$t_{1,2}$	Nominal wall thickness of reducer	mm	in.	...	App. D, Table D-1
t_c	Throat thickness of cover fillet weld, branch connection	mm	in.	127.4.8(B) 132.4.2(E)	127.4.8(D) 127.4.8(E)
t_e	Effective branch wall thickness	mm	in.	104.8.4(C)	...
t_m	Minimum required thickness of component, including allowances (c) for mechanical joining, corrosion, etc. (used with subscripts), namely t_{mb} = minimum thickness of branch t_{mh} = minimum thickness of header	mm	in.	104.1.2(A)[eqs. (7), (8), (9), (10)] 104.3.1(D.2) 104.3.1(E) 104.3.1(G) 104.3.3(C.3.1) 104.3.3(C.3.2) 104.4.1(B) 104.5.2(B)[eq. (13)] 104.5.3(A)	102.4.5 104.1.2(A) 104.3.1(D) 104.3.1(G) 127.4.2
t_n	Nominal wall thickness of component (used with subscripts), namely t_{nb} = nominal wall thickness of branch t_{nh} = nominal wall thickness of header t_{nr} = nominal thickness of reinforcement	mm	in.	102.3.2(A.3) 104.3.3 104.8.1[eq. (15)] 104.8.2[eq. (16)] 104.8.4(C) 127.4.8(B) 129.3.4.1 132.4.2(E)	127.4.4(B) 127.4.4(C) 127.4.8(D) 127.4.8(E) App. D, Fig. D-1 App. D, Table D-1
t_r	Thickness of reinforcing pad or saddle	mm	in.	104.3.1(D.2) 104.3.1(E)	104.3.1(D) App. D, Table D-1
t_s	Wall thickness of segment or miter	mm	in.	104.3.3(C.3)	...
t_w	Weld thickness	mm	in.	104.3.1(C.2)	127.4.8(G)
U	Anchor distance (length of straight line joining anchors)	m	ft	119.7.1(A.3)	...
W	Weld strength reduction factor	102.4.7 104.1.4	102.4.7
x_{min}	Size of fillet weld for slip-on and socket welding flanges or socket wall for socket welds	mm	in.	...	127.4.4(B)
Y	Resultant of movement to be absorbed by pipelines	119.7.1(A.3)	...

Symbol	Definition	Units		References	
		SI	U.S.	Paragraph	Table/Fig./App.
γ	A coefficient having values given in Table 104.1.2(A)	104.1.2(A.7)[eqs. (7), (8), (9), (10)]	104.1.2(A) App. A, Notes to Tables A-4, A-5, A-6, A-7, and A-9
γ	Branch offset dimension	mm	in.	...	App. D, Fig. D-1
Z	Section modulus of pipe	mm ³	in. ³	104.8.1[eq. (15)] 104.8.2[eq. (16)] 104.8.3[eq. (17)] 104.8.4(A) 104.8.4(C)	...
α	Angle between axes of branch and run	deg	deg	104.3.1(D.2) 104.3.1(E)	104.3.1(D)
α	Reducer cone angle	deg	deg	...	App. D, Table D-1
δ	Mismatch or offset	mm	in.	...	App. D, Table D-1
θ	Angle of miter cut	deg	deg	104.3.3	App. D, Table D-1
θ_n	Transition angle of branch reinforcement	deg	deg	...	App. D, Fig. D-1
\geq	Equal to or greater than
\leq	Equal to or less than

MANDATORY APPENDIX H

PREPARATION OF TECHNICAL INQUIRIES

H-1 INTRODUCTION

The ASME B31 Committee, Code for Pressure Piping, will consider written requests for interpretations and revisions of the Code rules, and develop new rules if dictated by technical development. The Committee's activities in this regard are limited strictly to interpretations of the rules or to the consideration of revisions to the present rules on the basis of new data or technology. The Introduction to this Code states "It is the owner's responsibility to determine which Code Section is applicable to a piping installation." The Committee will not respond to inquiries requesting assignment of a Code Section to a piping installation. As a matter of published policy, ASME does not approve, certify, rate, or endorse any item, construction, proprietary device, or activity, and, accordingly, inquiries requiring such consideration will be returned. Moreover, ASME does not act as a consultant on specific engineering problems or on the general application or understanding of the Code rules. If, based on the inquiry information submitted, it is the opinion of the Committee that the inquirer should seek professional assistance, the inquiry will be returned with the recommendation that such assistance be obtained.

Inquiries that do not provide the information needed for the Committee's full understanding will be returned.

H-2 REQUIREMENTS

Inquiries shall be limited strictly to interpretations of the rules or to the consideration of revisions to the present rules on the basis of new data or technology. Inquiries shall meet the following requirements:

(a) *Scope.* Involve a single rule or closely related rules in the scope of the Code. An inquiry letter concerning unrelated subjects will be returned.

(b) *Background.* State the purpose of the inquiry, which may be either to obtain an interpretation of Code rules, or to propose consideration of a revision to the present rules. Provide concisely the information needed for the Committee's understanding of the inquiry, being sure to include reference to the applicable Code Section, Edition, Addenda, paragraphs, figures, and tables. If sketches are provided, they shall be limited to the scope of the inquiry.

(c) *Inquiry Structure*

(1) *Proposed Question(s).* The inquiry shall be stated in a condensed and precise question format, omitting superfluous background information, and, where appropriate, composed in such a way that "yes" or "no" (perhaps with provisos) would be an acceptable reply. The inquiry statement should be technically and editorially correct.

(2) *Proposed Reply(ies).* Provide a proposed reply stating what it is believed that the Code requires. If in the inquirer's opinion, a revision to the Code is needed, recommended wording shall be provided in addition to information justifying the change.

H-3 SUBMITTAL

Inquiries should be submitted in typewritten form; however, legible handwritten inquiries will be considered. They shall include the name and mailing address of the inquirer, and be mailed to the following address:

Secretary
ASME B31 Committee
Two Park Avenue
New York, NY 10016-5990

MANDATORY APPENDIX J

QUALITY CONTROL REQUIREMENTS FOR BOILER EXTERNAL PIPING (BEP)

FOREWORD

This Mandatory Appendix contains the quality control requirements for boiler external piping. The following is that portion of Nonmandatory Appendix A, A-301 and A-302, of the ASME Boiler and Pressure Vessel Code, Section I, which is applicable to BEP.

J-1 QUALITY CONTROL SYSTEM

J-1.1 General

J-1.1.1 Quality Control System. The Manufacturer or assembler shall have and maintain a quality control system which will establish that all Code requirements, including material, design, fabrication, examination (by the Manufacturer), and inspection of boilers and boiler parts (by the Authorized Inspector), will be met. Provided that Code requirements are suitably identified, the system may include provisions for satisfying any requirements by the Manufacturer or user that exceed minimum Code requirements and may include provisions for quality control of non-Code work. In such systems, the Manufacturer may make changes in parts of the system that do not affect the Code requirements without securing acceptance by the Authorized Inspector. Before implementation, revisions to quality control systems of Manufacturers and assemblers of safety and safety relief valves shall have been found acceptable to an ASME designee if such revisions affect Code requirements.

The system that the Manufacturer or assembler uses to meet the requirements of this Section must be one suitable for his/her own circumstances. The necessary scope and detail of the system shall depend on the complexity of the work performed and on the size and complexity of the Manufacturer's (or assembler's) organization. A written description of the system the Manufacturer or assembler will use to produce a Code item shall be available for review. Depending upon the circumstances, the description may be brief or voluminous.

The written description may contain information of proprietary nature relating to the Manufacturer's (or assembler's) processes. Therefore, the Code does not require any distribution of this information, except for the Authorized Inspector or ASME designee.

It is intended that information learned about the system in connection with evaluation will be treated as confidential and that all loaned descriptions will be returned to the Manufacturer upon completion of the evaluation.

J-1.2 Outline of Features to Be Included in the Written Description of the Quality Control System

The following is a guide to some of the features that should be covered in the written description of the quality control system and that is equally applicable to both shop and field work.

J-1.2.1 Authority and Responsibility. The authority and responsibility of those in charge of the quality control system shall be clearly established. Persons performing quality control functions shall have sufficient and well-defined responsibility, the authority, and the organizational freedom to identify quality control problems and to initiate, recommend, and provide solutions.

J-1.2.2 Organization. An organization chart showing the relationship between management and engineering, purchasing, manufacturing, field assembling, inspection, and quality control is required to reflect the actual organization. The purpose of this chart is to identify and associate the various organizational groups with the particular function for which they are responsible. The Code does not intend to encroach on the Manufacturer's right to establish, and from time to time to alter, whatever form of organization the Manufacturer considers appropriate for its Code work.

J-1.2.3 Drawings, Design Calculations, and Specification Control. The Manufacturer's or assembler's quality control system shall provide procedures that will ensure that the latest applicable drawings, design calculations, specifications, and instructions, required by the Code, as well as authorized changes, are used for manufacture, assembly, examination, inspection, and testing.

J-1.2.4 Material Control. The Manufacturer or assembler shall include a system of receiving control that will ensure that the material received is properly identified and has documentation, including required material certifications or material test reports, to satisfy

Code requirements as ordered. The material control system shall insure that only the intended material is used in Code construction.

J-1.2.5 Examination and Inspection Program. The Manufacturer's quality control system shall describe the fabrication operations, including examinations, sufficiently to permit the Authorized Inspector to determine at what stages specific inspections are to be performed.

J-1.2.6 Correction of Nonconformities. There shall be a system agreed upon with the Authorized Inspector for correction of nonconformities. A nonconformity is any condition that does not comply with the applicable rules of this Section. Nonconformities must be corrected or eliminated in some way before the completed component can be considered to comply with this Section.

J-1.2.7 Welding. The quality control system shall include provisions for indicating that welding conforms to requirements of Section IX as supplemented by this Section.

J-1.2.8 Nondestructive Examination. The quality control system shall include provisions for identifying nondestructive examination procedures the Manufacturer will apply to conform with requirements of this Section.

J-1.2.9 Heat Treatment. The quality control system shall provide controls to ensure that heat treatments as required by the rules of this Section are applied. Means shall be indicated by which the Authorized Inspector can satisfy him/herself that these Code heat treatment requirements are met. This may be by review of furnace time – temperature records or by other methods as appropriate.

J-1.2.10 Calibration of Measurement and Test Equipment. The Manufacturer or assembler shall have a system for the calibration of examination, measuring, and test equipment used in fulfillment of requirements of this Section.

J-1.2.11 Records Retention. The Manufacturer or assembler shall have a system for the maintenance of radiographs and Manufacturers' Data Reports as required by this Section.

J-1.2.12 Sample Forms. The forms used in the quality control system and any detailed procedures for their use shall be available for review. The written description shall make necessary references to these forms.

J-1.2.13 Inspection of Boilers and Boiler Parts

J-1.2.13.1 Inspection of boilers and boiler parts shall be by the Authorized Inspector described in PG-91.

J-1.2.13.2 The written description of the quality control system shall include reference to the Authorized Inspector.

J-1.2.13.2.1 The Manufacturer (or assembler) shall make available to the Authorized Inspector at the Manufacturer's plant (or construction site) a current copy of the written description or the applicable quality control system.

J-1.2.13.2.2 The Manufacturer's quality control system shall provide for the Authorized Inspector at the Manufacturer's plant to have access to all drawings, calculations, specifications, procedures, process sheets, repair procedures, records, test results, and any other documents as necessary for the Inspector to perform his/her duties in accordance with this Section. The Manufacturer may provide such access either to his/her own files of such documents or by providing copies to the Inspector.

J-1.2.14 Inspection of Pressure-Relieving Valves

J-1.2.14.1 Inspection of safety, safety-relief, and power-actuated pressure-relieving valves shall be by designated representative of the ASME, as described in PG-73.3.

J-1.2.14.2 The written description of the quality control system shall include reference to the ASME designee.

J-1.2.14.2.1 The valve Manufacturer (or assembler) shall make available to the ASME designee at the Manufacturer's plant a current copy of the written description of the applicable quality control system.

J-1.2.14.2.2 The valve Manufacturer's (or assembler's) quality control system shall provide for the ASME designee to have access to all drawings, calculations, specifications, procedures, process sheets, repair procedures, records, test results, and any other documents as necessary for the designee to perform his/her duties in accordance with this Section. The Manufacturer may provide such access either to his/her own files of such documents or by providing copies to the designee.

MANDATORY APPENDIX N RULES FOR NONMETALLIC PIPING AND PIPING LINED WITH NONMETALS

FOREWORD

ASME B31.1 contains rules governing the design, fabrication, materials, erection, test, examination, inspection, operation, and maintenance of power piping systems. Experience in the application of nonmetallic materials for piping systems has shown that a number

of considerations exist for the use of these materials that are not addressed in the body of the Code. In order to address these, the requirements and recommendations for the use of nonmetallic piping (except in paras. 105.3, 108.4, 116, and 118) have been separately assembled in this Mandatory Appendix.

Chapter N-I

Scope and Definitions

N-100 GENERAL

This Mandatory Appendix provides requirements for the design, materials, fabrication, erection, testing, examination, and inspection of nonmetallic piping and metallic piping lined with nonmetals within the jurisdiction of the ASME B31.1 Power Piping Code. All references to the Code or to Code paragraphs in this Appendix are to the Section B31.1 Power Piping Code. In this Appendix, nonmetallic piping shall be limited to plastic and elastomer-based piping materials, with or without fabric or fibrous material added for pressure reinforcement. Metallic piping lined with nonmetals shall be limited to factory-made plastic-lined ferrous metal pipe, fittings, and flanges produced to one of the product standards for plastic-lined piping materials listed in Table N-126.1.

Standards and specifications incorporated in this Appendix are listed in Table N-126.1.

The provisions in Chapters I through VI and in Mandatory Appendices A through F are requirements of this Appendix only when specifically referenced herein.

N-100.1 Scope

N-100.1.1 All applicable requirements of para. 100.1 and the limitations of para. 105.3 shall be met in addition to those in this Appendix.

N-100.1.2 Use of this Appendix is limited to

- (A) water service.
- (B) nonflammable and nontoxic liquid, dry material, and slurry systems.
- (C) other services as specifically listed in section N-122.
- (D) metallic piping lined with nonmetals. If used in accordance with para. 122.9 for conveying corrosive liquids and gases, the design of the lined piping system shall meet the requirements of para. 104.7.

N-100.1.3 Nonmetallic piping systems shall not be installed in a confined space where toxic gases could be produced and accumulate, either from combustion of the piping materials or from exposure to flame or elevated temperatures from fire.

N-100.2 Definitions and Abbreviations

N-100.2.1 Terms and definitions relating to plastic and other nonmetallic piping materials shall be in accordance with ASTM D883. The following terms and definitions are in addition to those provided in ASTM D883:

adhesive: a material designed to join two other component materials together by surface attachment (bonding).

adhesive joint: a bonded joint made using an adhesive on the surfaces to be joined.

bonder: one who performs a manual or semiautomatic bonding operation.

bonding operator: one who operates a machine or automatic bonding equipment.

bonding procedure: the detailed methods and practices involved in the production of a bonded joint.

Bonding Procedure Specification (BPS): the document that lists the parameters to be used in the construction of bonded joints in accordance with the requirements of this Code.

butt-and-wrapped joint: a joint made by applying plies of reinforcement saturated with resin to the surfaces to be joined.

chopped roving: a collection of noncontinuous glass strands gathered without mechanical twist. Each strand is made up of glass filaments bonded together with a finish or size for application by chopper gun.

chopped strand mat: a collection of randomly oriented glass fiber strands, chopped or swirled together with a binder in the form of a blanket.

continuous roving: a collection of continuous glass strands wound into a cylindrical package without mechanical twist.

curing agent: a reactive material that, when combined with a resin material, reacts or polymerizes (cross-links) with the resin; also referred to as a hardener.

diluent: a reactive modifying material, usually a liquid, that reduces the concentration of a resin material to facilitate handling characteristics and improve wetting.

electrofusion: a heat fusion joining process where the heat source is an integral part of the fitting, such that when electric current is applied, heat is produced that melts and joins the plastics.

fire retardant resin: a specially compounded material combined with a resin material designed to reduce or eliminate the tendency to burn.

flexibilizer: a modifying liquid material added to a resinous mixture designed to allow the finished component the ability to be flexed or less rigid and more prone to bending.

grout: a heavily filled paste material used to fill crevices and transitions between piping components.

heat fusion joint: a joint made by heating the surfaces to be joined and pressing them together so they fuse and become essentially one piece.

hot-gas welded joint: a joint made by simultaneously heating a filler material and the surfaces to be joined with a stream of hot air or hot inert gas until the materials soften, after which the surfaces to be joined are pressed together and welded with the molten filler material.

hydraulic design basis (HDB)

for reinforced thermosetting resins (filament wound or centrifugally cast): one of a series of established stress values specified in ASTM Test Method D2992 for an RTR component, obtained by categorizing the long-term hydrostatic strength determined in accordance with Test Method D2992.

for thermoplastics: one of a series of established stress values specified in ASTM Test Method D2837 for a plastic compound, obtained by categorizing the long-term hydrostatic strength determined in accordance with Test Method D2837. This method subjects the material to tensile stress for an extended period of time, and extrapolates the creep results to estimate the tensile strength for a 50-yr life.

hydrostatic design stress (HDS): the estimated maximum tensile stress in the wall of the pipe in the circumferential orientation due to internal hydrostatic pressure that can be applied continuously with a high degree of certainty that failure of the pipe will not occur. Estimated by applying a design factor, typically 0.5 for thermoplastics in water service, to the HDB.

liner: a coating or layer of material, constructed as, applied to, or inserted within the inside surface of a piping component, intended to protect the structure from chemical attack, to inhibit erosion, or to prevent leakage under strain.

seal weld: the addition of material external to a joint, by welding or bonding, for the purpose of enhancing leak tightness.

solvent cement joint: a joint using a solvent cement to soften the surfaces to be joined, after which the joining surfaces are pressed together and become essentially one piece as the solvent evaporates.

stiffness factor: the measurement of a pipe's ability to resist deflection, as determined in accordance with ASTM D2412.

thixotropic agent: a material added to resin to impart high static shear strength (viscosity) and low dynamic shear strength.

ultraviolet absorber: a material that, when combined in a resin mixture, will selectively absorb ultraviolet radiation.

woven roving: a heavy glass fiber fabric reinforcing material made by the weaving of glass fiber roving.

N-100.2.2 Abbreviations. Abbreviations used in this Appendix denote materials and terms as follows:

Abbreviation	Term
ABS ¹	Acrylonitrile-butadiene-styrene
AP	Polyacetal
CP	Chlorinated polyether
CPVC ¹	Chlorinated poly (vinyl chloride)
DS	Design stress
FEP ¹	Perfluoro (ethylene propylene)
HDB	Hydrostatic design basis
HDPE	High density polyethylene
HDS	Hydrostatic design stress
PA ¹	Polyamide (nylon)
PB	Polybutylene
PE ¹	Polyethylene
PFA	Poly (perfluoroalkoxy)
POP	Poly (phenylene oxide)
PP ¹	Polypropylene
PPS	Polyphenylene
PR	Pressure rated
PTFE ¹	Polytetrafluoroethylene
PVC ¹	Poly (vinyl chloride)
PVDC	Poly (vinylidene chloride)
PVDF	Poly (vinylidene fluoride)
RTR	Reinforced thermosetting resin
SDR	Standard dimension ratio
SIDR	Standard inside diameter dimension ratio

NOTE:

(1) Abbreviation in accordance with ASTM D1600.

Chapter N-II

Design

PART 1 CONDITIONS AND CRITERIA

N-101 DESIGN CONDITIONS

N-101.1 General

N-101.1.1 The design conditions of para. 101 shall apply for the design of nonmetallic piping systems, except as noted below.

N-101.1.2 The design of nonmetallic piping systems must ensure the adequacy and suitability of material and its manufacture, considering at least the following:

- (A) tensile, compressive, flexural, shear strength, and modulus of elasticity at design temperature (long-term and short-term)
- (B) creep characteristics for the service conditions
- (C) design stress and its basis
- (D) coefficient of thermal expansion
- (E) ductility and plasticity
- (F) impact and thermal shock properties
- (G) temperature limits for the service
- (H) transition temperatures: melting and vaporization
- (I) toxicity of the material or of the gases produced by its combustion or exposure to elevated temperatures
- (J) porosity and permeability
- (K) test methods
- (L) methods of making joints and their efficiency
- (M) deterioration in the service environment
- (N) the effects on unprotected piping from external heat sources, including solar radiation

N-101.2 Pressure

N-101.2.1 Basis for Design Pressure. For metallic piping, design pressure is based on the maximum sustained operating pressure, in accordance with para. 101.2.2, with an allowance for occasional operation above design pressure, in accordance with para. 102.2.4. For nonmetallic piping, allowances for variations of pressure, temperature, or both above design conditions are not permitted. It is the designer's responsibility to identify probable occasional loads and to consider them in determining design pressure. See para. N-102.2.4(A).

N-101.3 Temperature

N-101.3.1 Basis for Design Temperature. For metallic piping, design temperature is based on the maximum

sustained operating temperature, in accordance with para. 101.3.2, with an allowance for occasional operation above design temperature, in accordance with para. 102.2.4. For nonmetallic piping, allowances for variations of pressure, temperature, or both above design conditions are not permitted. It is the designer's responsibility to identify probable occasional temperature variations and to allow for them in determining design temperature. See para. N-102.2.4(A).

N-101.3.2 Temperature Gradient Through Wall.

Because some nonmetallic piping materials have low thermal conductivity, there can be a significant temperature gradient through the component walls. Note (2) of Table N-102.2.1(A)-1 describes how this is considered in determining allowable stresses for nonmetallic materials.

N-102 DESIGN CRITERIA

N-102.1 General

These criteria cover pressure-temperature ratings for standard and specially designed components, allowable stresses, stress limits, and various allowances to be used in the design of piping and piping components.

N-102.2 Pressure-Temperature Ratings for Components

N-102.2.1 Components Having Specific Ratings

(A) Standard components have specific pressure-temperature ratings established in accordance with the standards listed in Table N-126.1. Other components may be used in accordance with para. N-102.3. The ratings of Tables N-102.2.1(A)-1, N-102.2.1(A)-2, and N-102.2.1(A)-3 are the limiting values for allowable stresses at temperature in this Appendix.

(B) The application of pressures exceeding the pressure-temperature ratings of valves and other standard components is not permitted. Valves shall be selected for operation within the limits defined in para. N-102.2.4.

N-102.2.2 Components Not Having Specific Ratings

(A) Pipe and other piping components for which allowable stresses have been developed in accordance with para. N-102.3, but which do not have specific pressure-temperature ratings, shall be rated in accordance with the rules for pressure design in para. N-104, within the range of temperatures for which stresses are

Table N-102.2.1(A)-1 Hydrostatic Design Stresses (HDS) and Recommended Temperature Limits for Thermoplastic Piping Components

ASTM Spec. No.	Material	Recommended Temperature Limits [Notes (1), (2), (3)]		Hydrostatic Design Basis, ksi, at 73°F	Hydrostatic Design Stress, S_a , ksi [Note (6)], at			
		Minimum, °F [Note (4)]	Maximum, °F [Note (5)]		73°F [Note (7)]	100°F	140°F	180°F
D2846, F441, F442	CPVC 4120	0	200	4.0	2.0	1.6	1.05	0.5
D2513, F2145	PA32312	-20	180	2.5	1.25	1.1	0.8	0.63
D2104,	PE2708	-30	140	1.60	0.80	0.64	0.4	...
D2239,	PE3608	-30	140	1.60	0.80	0.64	0.4	...
D2447,	PE3708	-30	140	1.60	0.80	0.64	0.4	...
D2513,	PE3710	-30	140	1.60	1.00	0.80	0.5	...
D2737,	PE4708	-30	140	1.60	0.80	0.64	0.4	...
D3035	PE4710	-30	140	1.60	1.00	0.80	0.5	...
...	POP2125 [Note (8)]	30	210
...	PP [Note (8)]	30	210
D1785,	PVC1120	0	100	4.0	2.0	1.2
D2241,	PVC1220	0	100	4.0	2.0	1.2
D2513,	PVC2110	0	100	2.0	1.0	0.6
D2672	PVC2112	0	100	2.5	1.25	0.8
	PVC2116	0	100	3.2	1.6	1.0
	PVC2120	0	100	4.0	2.0	1.2
F599	PVDC [Note (8)]	40	160
F491	PVDF [Note (8)]	0	275

NOTES:

- (1) These recommended limits are for low-pressure applications with water and other fluids that do not significantly affect the properties of the thermoplastic material. In conservative practice, the upper temperature limits may be reduced at higher pressures depending on the required service and expected life. Lower temperature limits are affected more by the environment, safeguarding, and installation conditions than by strength.
- (2) Because of low thermal conductivity, temperature gradients through the piping component wall may be substantial. Tabulated limits apply where more than half the wall thickness is at or below the stated temperature.
- (3) These recommended limits apply only to listed materials. Manufacturers should be consulted for temperature limits on specific types and kinds of materials not listed.
- (4) Minimum for installation.
- (5) Maximum for operation.
- (6) The HDS listed is for water service only, reflecting a design factor of 0.5 applied to the HDB. For other services, refer to PPI TR-9 or the manufacturer for recommended design factors.
- (7) Use these hydrostatic design stress values at all lower temperatures.
- (8) Nonpressure-boundary materials used primarily as liners. No established HDS.

Table N-102.2.1(A)-2 Design Stresses (DS) and Recommended Temperature Limits for Laminated Reinforced Thermosetting Resin Piping Components

ASTM Spec. No.	Type	Resin	Reinforcing	Recommended Temperature Limits [Note (1)]		Thickness, in.	Design Stress, S_b , ksi [Note (2)]
				Minimum, °F	Maximum, °F		
C582	I	Polyester	Glass fiber	-20	180	All	0.9
...	...	Furan	Carbon	-20	180
...	...	Furan	Glass fiber	-20	180
C582	II	Epoxy	Glass fiber	-20	180	$\frac{1}{8}$ – $\frac{3}{16}$	0.9
						$\frac{1}{4}$	1.2
						$\frac{5}{16}$	1.35
						$\frac{3}{8}$ and over	1.5

NOTES:

- (1) These recommended limits are for low-pressure applications with water and other fluids that do not significantly affect the properties of the thermoplastic material. In conservative practice, the upper temperature limits may be reduced at higher pressures, depending on the required service and expected life. Lower temperature limits are affected more by the environment, safeguarding, and installation conditions than by strength.
- (2) The design stress (DS) values are based on a design factor of 0.1 applied to the tested tensile strength of the pipe wall material, and are applicable only in the temperature range of -20°F through 180°F.

Table N-102.2.1(A)-3 Hydrostatic Design Basis (HDB) for Machine-Made Reinforced Thermosetting Resin Pipe

ASTM Spec. No. and Type	Grade	Class	Material Designation ASTM D2310	HDB Stress, S_c [Note (1)], at 73°F [Note (2)]	
				Cyclic, ksi [Note (3)]	Static, ksi [Note (4)]
D2517 filament wound	Glass fiber reinforced epoxy resin	No liner	RTRP-11AD	5.0	...
			RTRP-11AW	...	16.0
D2996 filament wound	Glass fiber reinforced epoxy resin	No liner	RTRP-11AD	5.0	...
			RTRP-11AW	...	16.0
		Epoxy resin liner, reinforced	RTRP-11FE	6.3	...
			RTRP-11FD	5.0	...
	Glass fiber reinforced polyester resin	Polyester resin liner, reinforced	RTRP-12EC	4.0	...
			RTRP-12ED	5.0	...
		RTRP-12EU	...	12.5	
		No liner	RTRP-12AD	5.0	...
			RTRP-12AU	...	12.5
D2997 centrifugally cast	Glass fiber reinforced polyester resin	Polyester resin liner, nonreinforced	RTRP-22BT	...	10.0
			RTRP-22BU	...	12.5
		Epoxy resin liner, nonreinforced	RTRP-21CT	...	10.0
			RTRP-21CU	...	12.5

NOTES:

- (1) A service (design) factor must be applied to the HDB values to obtain the HDS.
- (2) These HDB values apply only at 73°F. The standards covered in this Table only require testing at 23°C (73°F), using ASTM D2992 test procedures. ASTM D2992 makes provision for testing at higher temperatures, and manufacturers also usually test to higher temperatures. It is the designer's responsibility to verify that the manufacturer has test data covering the design temperature for the application, and that pressure-temperature ratings provided by the manufacturer reflect the service factor selected by the designer for the application.
- (3) When using the cyclic design basis, the service factor shall not exceed 1.0.
- (4) When using the static design basis, the service factor shall not exceed 0.5.

listed in Tables N-102.2.1(A)-1, N-102.2.1(A)-2, and N-102.2.1(A)-3.

(B) Pipe and other piping components that do not have allowable stresses or pressure-temperature ratings shall be qualified for pressure design as required in para. N-104.7.

N-102.2.3 Ratings: Normal Operating Condition. A nonmetallic piping system shall be considered safe for operation if the maximum anticipated coincident temperature and pressure that may act on any part or component of the system does not exceed the maximum pressure and temperature allowed by this Code for that particular part or component. The design pressure and temperature shall not exceed the pressure-temperature rating for the particular component and material as defined in the applicable specification or standard listed in Table N-126.1. For metallic piping with nonmetallic lining, the rules of para. 102.2.3 apply, provided that the suitability of the lining material for the maximum anticipated coincident temperature and pressure conditions has been established through prior successful extensive experience or tests.

N-102.2.4 Allowances for Pressure and Temperature Variations

(A) *Nonmetallic Piping.* Allowances for variations of pressure, temperature, or both above design conditions are not permitted. The most severe conditions of coincident pressure and temperature shall be used to determine the design conditions.

(B) *Metallic Piping Lined With Nonmetals.* Allowances for pressure and temperature variations provided in para. 102.2.4 are permitted only if the suitability of the lining material for the increased conditions is established through prior successful extensive experience or tests under comparable conditions.

N-102.2.5 Ratings at Transitions. Where two services that operate at different pressure-temperature conditions are connected, the valve segregating the two services shall be rated for the most severe service conditions. Other requirements of para. 102.2.5 must be considered where applicable.

N-102.3 Allowable Stresses and Other Limits

N-102.3.1 Allowable Stress Values

(A) *General.* Tables N-102.2.1(A)-1, N-102.2.1(A)-2, and N-102.2.1(A)-3 list recommended maximum allowable stresses in the form of hydrostatic design stresses (HDS), allowable design stresses (DS), and the hydrostatic design basis (HDB) that may be used in design calculations except where modified by other provisions of this Appendix. The use of hydrostatic design stresses for calculations other than pressure design has not been established. The basis for determining allowable stresses and pressures is outlined in (B) below. The allowable stresses are grouped by materials and listed for stated

temperatures. Where sufficient data have been provided, straight-line interpolation between temperatures is permissible. The materials listed are available from one or more manufacturers, and some manufacturers may publish somewhat different HDS values for the materials than the values listed in Tables N-102.2.1(A)-1, N-102.2.1(A)-2, and N-102.2.1(A)-3. The manufacturer's published values for these materials are acceptable for use where they have been established in accordance with (B) below and verified in accordance with para. N-104.7.

(B) *Basis for Allowable Stresses for Internal Pressure*

(B.1) *Thermoplastics.* A method of determining hydrostatic design basis (HDB) and pressure rating (PR) is described in ASTM D2837, which also describes application of a design factor to the HDB to determine hydrostatic design stress (HDS) and pressure rating (PR). Hydrostatic design stresses are provided in Table N-102.2.1(A)-1, based on HDB values listed in PPI TR-4 and design factors for water from PPI TR-9. Design factors for other services are also given in PPI TR-9.

(B.2) *Reinforced Thermosetting Resin (Laminated).* For laminated piping components, the design stresses (DS) are listed in Table N-102.2.1(A)-2. These typically are based on one-tenth of the minimum tensile strengths specified in Table 1 of ASTM C582.

(B.3) *Reinforced Thermosetting Resin (Filament Wound and Centrifugally Cast).* For filament wound and centrifugally cast piping components, hydrostatic design basis (HDB) values are listed in Table N-102.2.1(A)-3. These values may be obtained by procedures in ASTM D2992. HDS may be obtained by multiplying the HDB by a service (design) factor¹ selected for the application, in accordance with procedures described in ASTM D2992, within the following limits:

(B.3.1) When using the cyclic HDB from Table N-102.2.1(A)-3, the service (design) factor shall not exceed 1.0.

(B.3.2) When using the static HDB from Table N-102.2.1(A)-3, the service (design) factor shall not exceed 0.5.

N-102.3.2 Limits of Calculated Stresses Due to Sustained Loads

(A) *Internal Pressure Stresses.* The limits for stress due to internal pressure are provided in para. N-104.1.2.

(B) *External Pressure Stresses.* Thermoplastic piping, reinforced thermosetting resin piping, and metallic piping lined with nonmetals, subject to external pressure, shall be considered safe when the wall thickness and/or means of stiffening meet the requirements of para. N-104.7.2.

¹ The service (design) factor, *F*, should be selected by the designer after evaluating fully the service conditions and the engineering properties of the specific material under consideration. Aside from the limits in paras. N-102.3.1(B.3.1) and (B.3.2), it is not the intent of this Code to specify service (design) factors.

(C) *External Loading Stresses.* Design of piping under external loading shall be based on the following:

(C.1) For thermoplastic piping, see ASTM D2774 and AWWA M23.

(C.2) For reinforced thermosetting resin (RTR) piping, see ASTM D3839 and AWWA M45.

(C.3) The allowable deflection for RTR and thermoplastic pipe shall be not more than 5% of the pipe inside diameter.

(C.4) Where other nonmetallic piping is intended for use under conditions of external loading due to underground installation, it shall be subject to a crushing or three-edge bearing test, in accordance with ASTM C14 or ASTM C301, and the allowable load shall be 25% of the minimum value obtained. The limits of calculated stresses due to external loading in aboveground installations shall be qualified in accordance with para. N-104.7.2.

N-102.3.3 Limits of Calculated Stresses Due to Occasional Loads

(A) *Operation.* The sum of the stresses in any component in a piping system due to sustained loads, such as pressure and weight, and of the stresses produced by occasional loads, such as wind or earthquake, shall not exceed the limits in the applicable part of para. N-102.3.2. Wind and earthquake forces need not be considered as acting concurrently. (For nonmetallic piping, anticipated transient pressure and temperature variations are not considered occasional loads.)

(B) *Test.* Stresses due to test conditions are not subject to the limitations in (A) above. It is not necessary to consider other occasional loads, e.g., wind and earthquake, as occurring concurrently with test loads.

N-102.4 Allowances

(A) *Erosion, Corrosion, Threading, and Grooving.* In determining the minimum required thickness of a piping component, allowances shall be included for erosion and for thread depth or groove depth.

(B) *Mechanical Strength.* When necessary, pipe wall thicknesses shall be increased to prevent overstress, damage, collapse, or buckling due to superimposed loads from supports, ice formation, backfill, or other causes. Where increasing thickness will cause excessive local stress or is otherwise impractical, the required strength may be obtained through the use of additional supports, braces, or other means without an increased wall thickness. Particular consideration should be given to the mechanical strength of a small branch connected to large piping or to equipment.

PART 2

PRESSURE DESIGN OF PIPING COMPONENTS

N-103 CRITERIA FOR PRESSURE DESIGN

The design of piping components shall consider the effects of pressure, temperature, and other factors in

accordance with paras. N-102.2 and N-104.1 through N-104.7, and provide for allowances in accordance with para. N-102.4. In addition, the design shall be checked for adequacy of mechanical strength under other applicable loadings as required in paras. N-102.3.2 and N-102.3.3.

N-104 PRESSURE DESIGN OF COMPONENTS

N-104.1 Straight Pipe

N-104.1.1 The required minimum wall thickness of straight sections of pipe, t_m , shall be determined as

$$t_m = t + c \quad (1)$$

where

c = the sum of the mechanical allowances (thread or groove depth), plus erosion and/or corrosion allowance, and the manufacturer's minus tolerance for product wall thickness, in. For threaded components, the nominal thread depth shall apply. For mechanical surfaces or grooves where a tolerance is not specified, the tolerance shall be assumed to be 0.02 in. in addition to the specified depth of the thread or groove.

t = pressure design thickness, in., as calculated in para. N-104.1.2 for internal pressure, or in accordance with para. N-104.1.3 for external pressure

t_m = minimum required thickness, in.

N-104.1.2 Straight Pipe Under Internal Pressure

(A) The internal pressure design thickness, t , shall be not less than that calculated with the following equations:

(A.1) For thermoplastic pipe

$$t = \frac{D}{2S_a/P + 1} \quad (2)$$

(A.2) For reinforced thermosetting resin (laminated)

$$t = \frac{D}{2S_b/P + 1} \quad (3)$$

(A.3) For reinforced thermosetting resin (filament wound and centrifugally cast)

$$t = \frac{D}{2S_cF/P + 1} \quad (4)$$

where

D = outside diameter of pipe, in.

F = service design factor in accordance with para. N-102.3.1(B.3)

P = internal design gage pressure, psi

S_a = hydrostatic design stress from Table N-102.2.1(A)-1

S_b = design stress from Table N-102.2.1(A)-2

S_c = hydrostatic design basis from Table N-102.2.1(A)-3

(A.4) *Metallic Pipe Lined With Nonmetals.* Pressure limitations shall be those established by the manufacturer, considering both pressure and temperature limitations of the metal housings and sealing ability of the liner at flanged joints. In addition, the metallic pipe shall meet the requirements of the mandatory sections of ASME B31.1, including the pressure design requirements of Chapter II.

(B) The internal pressure design thickness, t , in (A.1) and (A.2) above shall not include any thickness of pipe wall reinforced with less than 30% (by weight) of reinforcing fibers, or added liner thickness.

N-104.1.3 Straight Pipe Under External Pressure

(A) *Thermoplastic Pipe.* The external pressure design thickness shall be qualified as required by para. N-104.7.

(B) *Reinforced Thermosetting Resin Pipe.* For determining design pressure thickness for straight pipe under external pressure, the procedures outlined in ASTM D2924 shall be followed. A safety factor of at least 4 shall be used.

(C) *Metallic Pipe Lined With Nonmetals*

(C.1) The external pressure design thickness for the base (outer) material shall be determined in accordance with para. 104.1.3.

(C.2) The external pressure design thickness, t , for the lining material shall be qualified as required by para. N-104.7.

N-104.2 Curved and Mitered Segments of Pipe

(A) *Pipe Bends.* The minimum required thickness, t_m , of a pipe bend after bending shall be determined as for straight pipe in accordance with para. N-104.1.

(B) *Elbows.* Manufactured elbows not in accordance with para. N-102.2.1 shall meet the requirements of para. N-104.7.

(C) *Mitered Bends.* Mitered bend sections shall meet the requirements of para. N-104.7.

N-104.3 Intersections

N-104.3.1 Branch Connections

(A) *General.* A pipe having a branch connection is weakened by the opening that must be made in it. Unless the wall thickness of the pipe is sufficiently in excess of that required to sustain the pressure, it is necessary to provide added reinforcement. The amount of reinforcement required shall be in accordance with the requirements of para. N-104.7 except as provided in (B) and (C) below.

(B) *Branch Connections Using Fittings.* A branch connection shall be considered to have adequate strength to sustain the internal and external pressure that will be applied to it if a fitting (at tee, lateral, or cross) is utilized in accordance with para. N-102.2.1.

(C) *Additional Considerations.* The requirements of (A) and (B) above are designed to ensure satisfactory performance of a branch connection subjected only to internal or external pressure. The designer shall also consider the following:

(C.1) External forces and moments may be applied to a branch connection by a thermal expansion and contraction, by dead and live loads, by vibration or pulsating pressure, or by movement of piping terminals, supports, and anchors.

(C.2) Adequate flexibility shall be provided in branch piping to accommodate movements of the run piping.

(C.3) Ribs, gussets, or clamps may be used for pressure-strengthening a branch connection in lieu of the reinforcement required by (A) above if the adequacy of the design is established in accordance with para. N-104.7.

N-104.4 Closures

Closures in piping systems, e.g., those provided for temporary or future lateral or end-point branches, shall be made using fittings, flanges, or parts listed in Table N-126.1 or designed in accordance with paras. N-104.3, N-104.5, and N-104.7.

N-104.5 Pressure Design of Flanges

(A) *General*

(A.1) Nonmetallic flanges that are rated in accordance with published ASTM standards listed in Table N-126.1 shall be considered suitable for use within the limitations specified in this Appendix. Alternatively, flanges shall be in accordance with para. 103 or may be designed in conformance with the requirements of this paragraph or para. N-104.7.

(A.2) Flanges for use with ring-type gaskets may be designed in accordance with Section VIII, Division 1, Mandatory Appendix 2 of the ASME Boiler and Pressure Vessel Code, except that the allowable stresses for non-metallic components shall govern. All nomenclature shall be as defined in the ASME Code, except the following:

P = design gage pressure

S_a = bolt design stress at atmospheric temperature (bolt design stresses shall not exceed those in Mandatory Appendix A)

S_b = bolt design stress at design temperature (bolt design stresses shall not exceed those in Mandatory Appendix A)

S_f = allowable stress for flange material from Tables NA-102.2.1(A)-1, NA-102.2.1(A)-2, and NA-102.2.1(A)-3

(A.3) The flange design rules in (A.2) above are not applicable for designs employing full-face gaskets that extend beyond the bolts. The forces and reactions in

such a joint differ from those joints employing ring-type gaskets, and the flanges should be designed in accordance with Section VIII, Division 1, Nonmandatory Appendix Y of the ASME Boiler and Pressure Vessel Code. (Note that the plastic flange sealing surface may be more irregular than the sealing surface of a steel flange. For this reason, thicker and softer gaskets may be required for plastic flanges.)

(B) *Blind Flanges.* Blind flanges shall be in accordance with para. 103 or, alternatively, may be designed in accordance with para. 104.5.2, except that the allowable stresses for nonmetallic components shall be taken from the data in Tables N-102.2.1(A)-1, N-102.2.1(A)-2, and N-102.2.1(A)-3. Otherwise, the design of blind flanges shall meet the requirements of para. N-104.7.

N-104.6 Reducers

Reducers not in compliance with para. N-102.2.1 shall meet the requirements of para. N-104.7.

N-104.7 Design of Other Components

N-104.7.1 Listed Components. Pressure-retaining components manufactured in accordance with standards listed in Table N-126.1 may be utilized in accordance with para. N-102.2.1.

N-104.7.2 Unlisted Components and Products. For nonmetallic pressure-retaining components and piping products not complying with the standards and specifications listed in Table N-126.1, and for proprietary components and joints for which the rules in paras. N-103 through N-104.6 do not apply, pressure design shall be based on calculations consistent with the design criteria of this Appendix and the Code. This must be substantiated by one or more of the following, with consideration given to applicable dynamic effects, e.g., vibration and cyclic operation, the effects of thermal expansion or contraction, and the load effects of impact and thermal shock:

(A) extensive successful service experience under comparable design conditions with similarly proportioned components or piping elements made of the same or like material

(B) performance tests under design conditions, including applicable dynamic and creep effects, continued for a time period sufficient to determine the acceptability of the component or piping element for its design life

For either (A) or (B) above, reasonable interpolations between sizes and pressure classes, and reasonable analogies among related materials, are permitted.

PART 3 SELECTION OF PIPING COMPONENTS

N-105 PIPE

Pipe and tube conforming to the standards and specifications listed in Table N-126.1 shall be used within the

limitations of para. N-124 and within any limitations imposed by the applicable standards themselves.

N-106 FITTINGS

N-106.1 Listed Fittings

Fittings made in accordance with the standards and specifications listed in Table N-126.1 shall be used within the limitations of para. N-124, within limitations imposed by this Appendix or the body of this Code for specific service or application, and within any limitations imposed by the applicable standards themselves.

N-106.2 Unlisted Fittings

Fittings not covered by the standards listed in Table N-126.1 may be used if they conform to para. N-104.7.

N-107 VALVES

N-107.1 Listed Valves

Valves conforming to the standards and specifications listed in Table N-126.1 shall be used within the specified pressure–temperature ratings. Metallic valves conforming to the standards and specifications listed in Table 126.1, and used in nonmetallic piping, shall be used within the specified pressure–temperature ratings.

N-107.2 Unlisted Valves

Valves not complying with para. N-107.1 shall be of a design, or equal to the design, that the manufacturer recommends for the service and that conforms with para. N-104.7.2.

PART 4

SELECTION AND LIMITATIONS OF PIPING JOINTS

N-110 GENERAL

Joints shall be suitable for the pressure–temperature design conditions and shall be selected giving consideration to joint tightness and mechanical strength under those conditions (including external loadings), the materials of construction, the nature of the fluid service, and the limitations of paras. N-111 through N-118.

N-111 BONDED JOINTS

N-111.1 General Limitations

Unless limited elsewhere in para. N-111, joints made by bonding in accordance with para. N-127 and examined in accordance with para. N-136.4 may be used within other limitations on materials and piping components in this Appendix.

N-111.2 Specific Limitations

N-111.2.1 Hot Gas Welded Joints. Hot gas welded joints shall not be used for B31.1 nonmetallic pressure piping.

N-111.2.2 Butt-and-Wrapped Joints. Butt-and-wrapped joints in RTR piping shall be made with sufficient strength to withstand the design pressure and external loadings.

N-112 FLANGED JOINTS

(A) *General Limitations.* Unless limited elsewhere in para. N-112, flanged joints may be used, considering the requirements for materials in Chapter N-III, and for piping components in Part 3 of Chapter N-II, within the following limitations:

(A.1) *Joints With Flanges of Different Ratings.* Where flanges of different ratings are bolted together, the rating of the joint shall be that of the lower-rated flange. Bolting torque shall be limited so that excessive loads will not be imposed on the lower-rated flange in obtaining a tight joint.

(A.2) *Metallic to Nonmetallic Flanged Joints.* Where metallic and nonmetallic flanges are to be joined, both should be flat-faced. Full-faced gaskets are preferred. If full-faced gaskets are not used, bolting torque shall be limited so that the nonmetallic flange is not overloaded.

N-113 EXPANDED OR ROLLED JOINTS

Expanded or rolled joints are not permitted in nonmetallic piping systems.

N-114 THREADED JOINTS

N-114.1 General Limitations

N-114.1.1 Threaded joints may be used within the requirements for materials in Chapter N-III, and on piping components in Part 3 of Chapter N-II within the limitations below.

N-114.1.2 Threaded joints shall be avoided in any service where severe erosion or cyclic loading may occur, unless the joint has been specifically designed for these conditions.

N-114.1.3 Where threaded joints are designed to be seal welded, thread-sealing compound shall not be used.

N-114.1.4 Layout of piping should minimize reaction loads on threaded joints, giving special consideration to stresses due to thermal expansion or contraction and the operation of valves.

N-114.1.5 Metallic-to-nonmetallic and dissimilar nonmetallic threaded joints are not permitted in piping NPS 2½ and larger.

N-114.2 Specific Limitations

N-114.2.1 Thermoplastic Piping. Threaded joints in thermoplastic piping shall conform to the following requirements:

(A) The pipe wall shall be at least Schedule 80 thickness.

(B) Pipe threads shall conform to ASME B1.20.1 NPT. Threaded fittings shall be compatible with that standard.

(C) A suitable thread lubricant and sealant shall be specified.

(D) Threaded piping joints are not permitted in polyolefin materials,² because of creep characteristics that must be considered.

(E) For PVC piping, the allowable pressure for threaded piping shall be no more than 50% of that for unthreaded piping of the same wall thickness and material grade.

N-114.2.2 Thermosetting Resin Piping. Threaded joints in thermosetting resin piping shall conform to the following requirements:

(A) Threads shall be factory cut or molded on pipe ends and in matching fittings, with allowance for thread depth in accordance with para. N-104.1.1.

(B) Threading of plain ends of piping is not permitted, except where such male threads are limited to the function of forming a mechanical lock with matching female threads during bonding.

(C) Factory cut or molded threaded nipples, couplings, or adapters bonded to plain end components may be used where necessary to provide connections to threaded metallic piping.

N-115 FLARED LINING JOINTS FOR METALLIC PIPING LINED WITH NONMETALS

The following apply:

(A) *Welding.* Welding is not permitted on lined components in the field. Welding performed by the manufacturer to produce pipe, fittings, and flanges to be used for joints in elastomeric-lined piping systems shall be performed so as to maintain the continuity of the lining and its serviceability.

(B) *Flared Linings*

(B.1) *General.* Flared ends of linings made in accordance with the rules in this paragraph may be used, subject to material limitations.

(B.2) *Specific Requirements.* Flaring shall be limited to applications that do not affect the serviceability of the lining.

N-116 BELL END JOINTS

Paragraph 116 applies.

² The polyolefin group of materials includes polyethylene, polypropylene, and polybutylene.

N-118 PROPRIETARY JOINTS

Metal coupling, mechanical, gland, and other proprietary joints may be used within the limitations on materials in Part 3 of this Chapter.

**PART 5
EXPANSION, FLEXIBILITY, AND PIPE-SUPPORTING
ELEMENTS**

N-119 EXPANSION AND FLEXIBILITY**N-119.1 General Concepts**

N-119.1.1 Elastic Behavior. The concept of piping strain imposed by the restraint of thermal expansion or contraction, and by external movements, applies in principle to nonmetals. Nevertheless, the assumption that stresses can be predicted from these strains in a nonmetallic piping system, based on the linear elastic characteristics of the material, is generally not valid. The variation in elastic characteristics between otherwise similar material types, between source manufacturers, and between batch lots of the same source material can at times be significant. If a method of flexibility analysis that assumes elastic behavior is used, the designer must be able to demonstrate its validity for the system and must establish conservative limits for the computed stresses.

N-119.1.2 Overstrained Behavior. Stresses cannot be considered proportional to displacement strains in nonmetallic piping systems where an excessive level of strain may be produced in a localized area of the system, and in which elastic behavior of the piping material is uncertain (see unbalanced systems in para. 119.3). Overstrain must be minimized by effective system routing in order to avoid the necessity of a requirement for special joints or expansion devices for accommodating excessive displacements.

N-119.1.3 Progressive Failure. In thermoplastics and some thermosetting resins, displacement strains are not likely to produce immediate failure of piping, but may produce unacceptable distortion. Thermoplastics, particularly, are prone to progressive deformation that may occur upon repeated thermal cycling or under prolonged exposure to elevated temperature.

N-119.1.4 Brittle Failure. In brittle thermosetting resins, the materials are essentially rigid in behavior and may readily develop high-displacement stresses, to the point of sudden breakage or fracture, under moderate levels of strain.

N-119.5 Flexibility

N-119.5.1 Piping systems shall have sufficient flexibility to prevent the effects of thermal expansion or

contraction, the movement of pipe supports or terminal points, or pressure elongation from causing

(A) failure of piping or supports from overstrain or fatigue

(B) leakage at joints

(C) unacceptable stresses or distortion in the piping or in connected equipment

N-119.5.2 Where nonmetallic piping and components are used, piping systems must be designed and routed so that flexural stresses resulting from displacements due to expansion, contraction, and other causes are minimized. This concept requires special attention for supports and restraints, the terminal connections, and for the techniques outlined in para. 119.5.1. Further information on the design of thermoplastic piping can be found in PPI TR-21.

N-119.5.3 For metallic piping lined with nonmetals, the designer must consider the integrity of the lining in designing for piping flexibility. This is a special consideration for linings less flexible than the metallic piping, e.g., glass or ceramics.

N-119.6 Properties for Flexibility Analysis

N-119.6.1 Thermal Expansion Data. Table N-119.6.1 of this Appendix lists coefficients of thermal expansion for several nonmetallic materials. More-precise values in some instances may be obtained from the manufacturers of these materials. If the values are to be used in stress analysis, the thermal displacements shall be determined as indicated in para. 119.

N-119.6.2 Modulus of Elasticity. Table N-119.6.2 lists representative data on the tensile modulus of elasticity, E , for several nonmetals. More-precise values in some instances may be obtained from the materials manufacturer. (Note that the modulus may vary with the geometrical orientation of a test sample for filler-reinforced, filament-wound, or impregnated nonmetallic materials.) For materials and temperatures not listed, refer to an authoritative source, e.g., publications of the National Institute of Standards and Technology.

N-119.6.3 Poisson's Ratio. For nonmetals, Poisson's ratio will vary widely, depending upon materials and temperature. For that reason, formulas used in linear elastic stress analysis can be used only if the manufacturer has test data to substantiate the use of a specific Poisson's ratio for that application.

N-119.6.4 Dimensions. The nominal thickness and outside diameters of pipe and fittings shall be used in flexibility calculations.

N-119.6.5 Metallic Pipe Lined With Nonmetals. Flexibility and stress analysis for metallic pipe lined with nonmetals shall be in accordance with para. 119, except that any limitations on allowable stresses or moments

Table N-119.6.1 Thermal Expansion Coefficients, Nonmetals

Material Description	Mean Coefficients, U.S. Customary Units		Mean Coefficients, Metric Units	
	10^{-6} in./in./°F	Range, °F	10^{-6} mm/mm/°C	Range, °C
Thermoplastics				
PVC Type 1120	30	23–37	54	–5 to +3
PVC Type 2116	40	37–45	72	3–7
CPVC 4120	34	...	61	...
PE2708	100	32–120	180	0–49
PE3608	90	32–120	162	0–49
PE3708	90	32–120	162	0–49
PE3710	90	32–120	162	0–49
PE4708	80	32–120	144	0–49
PE4710	80	32–120	144	0–49
Polypropylene	43	...	77	...
Poly(vinylidene chloride)	85	...	153	...
Poly(vinylidene fluoride)	100	...	180	...
Reinforced Thermosetting Resins				
Epoxy-glass, centrifugally cast	9–13	...	16–23.5	...
Epoxy-glass, filament-wound	9–13	...	16–23.5	...
Polyester-glass, centrifugally cast	9–15	...	16–27	...
Polyester-glass, filament-wound	9–11	...	16–20	...
Polyester-glass, hand lay-up	12–15	...	21.5–27	...
Other				
Hard rubber (Buna N)	40	...	72	...

GENERAL NOTE: Values in this Table are representative. Values at actual design temperature shall be obtained from the manufacturers.

Table N-119.6.2 Modulus of Elasticity, Nonmetals

Material Description	<i>E</i> , ksi (73.4°F) [Note (1)]	<i>E</i> , MPa (23°C) [Note (1)]
Thermoplastics		
PVC Type 1120	420	2 895
PVC Type 2116	360	2 485
CPVC 4120	420	2 895
PE2708	100	690
PE3608	125	860
PE3708	125	860
PE3710	125	860
PE4708	130	897
PE4710	130	897
Polypropylene	120	825
Poly(vinylidene chloride)	100	690
Poly(vinylidene fluoride)	194	1 340
Thermosetting Resins, Axially Reinforced		
Epoxy-glass, centrifugally cast	1,200–1,900	8 275–13 100
Epoxy-glass, filament-wound	1,100–2,000	7 585–13 790
Polyester-glass, centrifugally cast	1,200–1,900	8 275–13 100
Polyester-glass, filament-wound	1,100–2,000	7 585–13 790
Polyester-glass, hand lay-up	800–1,000	5 515–6 895
Other		
Hard rubber (Buna N)	300	2 070

NOTE:

- (1) The modulus of elasticity values for thermosetting resin pipe are given in the longitudinal direction; different values may apply in the circumferential or hoop direction. The modulus of elasticity values for thermoplastic resin pipe are temperature-dependent and stress-time related. In all cases for materials listed in this Table, manufacturers shall be consulted for specific product information.

recommended by the manufacturers of the lined pipe shall be observed.

N-119.7 Analysis

N-119.7.1 Formal stress analysis is not required for systems that

(A) are duplicates, or replacements without significant change, of successfully operating installations

(B) can readily be judged adequate by comparison with previously analyzed systems or

(C) are routed with a conservative margin of inherent flexibility, or employ joining methods or expansion joint devices, or a combination of these methods, in accordance with the applicable manufacturer's instruction

N-119.7.2 A substantiating stress analysis is required for a system not meeting the above criteria. The designer may demonstrate that adequate flexibility exists by employing a simplified, approximate, or comprehensive stress analysis, using a method that can be

shown to be valid for the specific case. If essentially elastic behavior can be demonstrated for a piping system (see para. N-119.1.1), the methods outlined in para. 119 may be applicable.

N-119.7.3 Special attention shall be given to movement (displacement or rotation) of the piping with respect to supports and points of close clearance. Movements of a run at the junction of a small branch shall be considered in determining the need for flexibility in the branch.

N-120 LOADS ON PIPE-SUPPORTING ELEMENTS

Paragraph 120 applies.

N-121 DESIGN OF PIPE-SUPPORTING ELEMENTS**N-121.1 General**

In addition to the other applicable requirements of paras. 120 and 121, supports, guides, and anchors shall be selected and applied to comply with the requirements of para. N-119 and the following:

N-121.1.1 Support or restraint loads shall be transmitted to piping attachment or bearing points in a manner that will preclude pipe-wall deformation or damage. Padding or other isolation material should be installed in support or restraint clearance spaces for added protection.

N-121.1.2 Valves and in-line components should be independently supported to prevent the imposition of high load effects on the piping or adjacent supports.

N-121.1.3 Nonmetallic piping should be guarded where such systems are exposed to casual damage from traffic or other work activities.

N-121.1.4 A manufacturer's recommendations for support shall be considered.

N-121.11 Thermoplastic and RTR Piping

Supports shall be spaced to avoid excessive displacement at design temperature and within the design life of the piping system. Decreases in the modulus of elasticity with increasing temperature, and creep of the material, with time, shall be considered where applicable. The coefficient of thermal expansion of most plastic materials is high and must be considered in the design and location of supports and restraints.

N-121.12 Burial of Thermoplastic and RTR Pipe

N-121.12.1 Design. Buried pipe design requires consideration of burial depth, soil type, and compaction to determine the external loads on the pipe. For AWWA C900 PVC pipe, AWWA Manual M23 outlines applicable design procedures for water utility service.

For AWWA C950 RTR pipe, AWWA Manual M45 outlines similar procedures. It is the designer's responsibility to verify that the procedures are applicable for other services and piping materials. Minimum pipe stiffness for RTR pipe shall meet the requirements of AWWA C950 for 5% deflection. The minimum stiffness shall be determined at 5% deflection using the apparatus and procedures of ASTM D2412.

N-121.12.2 Installation. The pipe manufacturer's recommendations shall be equal to or more stringent than those described in ASTM D3839 for RTR pipe or ASTM D2774 for thermoplastic pipe. The manufacturer's recommendations shall be followed.

PART 6 SYSTEMS

N-122 DESIGN REQUIREMENTS PERTAINING TO SPECIFIC PIPING SYSTEMS

The use of nonmetallic piping materials and components, under the scope of this Appendix, shall be limited to those services and conditions stated in para. 100.1.2 or specifically permitted in this section. In addition,

(A) nonmetallic materials shall not be used under severe cyclic conditions unless it can be demonstrated that the materials are suitable for the intended service in accordance with para. N-104.7.

(B) these materials shall be appropriately protected against transient or operating temperatures and pressures beyond design limits, and shall be adequately protected against mechanical damage.

(C) limitations on the use or application of materials in this Appendix apply to pressure-containing parts. They do not apply to the use of materials for supports, linings, gaskets, or packing.

N-122.7 Piping for Flammable or Combustible Liquids

N-122.7.1 Polyethylene (PE) and reinforced thermosetting resin (RTR) pipe may be used for flammable or combustible liquids in buried installations only. The fluid temperatures shall not exceed 140°F (60°C) and pressures shall be limited to 150 psi (1 000 kPa). Particular care must be exercised to prevent damage to RTR

piping at the connection to the main or other facility. Precautions shall be taken to prevent crushing or shearing of RTR piping due to external loading or settling of backfill and to prevent damage or pullout from the terminal connection resulting from thermal expansion or contraction.

RTR piping may terminate above ground and outside a building, provided that

(A) the aboveground portion of the RTR pipe is completely enclosed in a conduit or casing of sufficient strength to provide protection from external damage and deterioration. Where a flexible conduit is used, the top of the riser must be attached to a solid support. The conduit or casing shall extend a minimum of 6 in. below grade.

(B) the RTR pipe is not subjected to excessive stresses due to external loading.

N-122.8 Piping for Flammable Gases, Toxic Gases or Liquids, or Nonflammable Nontoxic Gases

N-122.8.1 Polyethylene (PE) pipe may be used for natural gas service in buried installations only. The fluid temperatures shall not exceed 140°F (60°C) nor be below -20°F (-30°C), and pressures shall be limited to 100 psi (690 kPa). Pipe joints shall be heat fused in accordance with a Bonding Procedure Specification meeting the requirements of N-127.

N-122.9 Piping for Corrosive Liquids and Gases

N-122.9.1 For nonmetallic piping used to convey corrosive or hazardous liquids or gases in accordance with para. 122.9, the design shall meet the requirements of para. N-104.7.2, in addition to the materials limitation requirements of para. N-124.9.

N-122.9.2 Aboveground nonmetallic piping conveying corrosive or hazardous fluids shall be installed in a guarded manner that will prevent damage during construction, operation, or service.

N-122.9.3 For metallic piping lined with nonmetals used to convey corrosive or hazardous liquids or gases in accordance with para. 122.9, the design shall meet the requirements of para. N-104.7.2.

Chapter N-III Materials

N-123 GENERAL REQUIREMENTS

Paragraph N-123 provides limitations and qualifications for materials based on their inherent properties. The use of these materials in piping may also be subject to requirements and limitations in other parts of the Code.

N-123.1 Materials and Specifications

N-123.1.1 Listed Materials. Listed materials used in pressure-containing piping shall have basic allowable stresses and other design limits as covered in para. N-102.3.

N-123.1.2 Unlisted Materials. Unlisted materials used in pressure-containing piping shall have basic allowable stresses and other design limits as covered in para. N-102.3 or on a more conservative basis. Unlisted materials shall be qualified in accordance with the requirements of N-104.7.2.

N-123.1.3 Unknown Materials. Materials of unknown specification or standard shall not be used.

N-124 LIMITATIONS ON MATERIALS

N-124.1 Temperature Limitations

The designer shall determine that materials that meet other requirements of this Appendix are suitable for the fluid service throughout the operating temperature range of the systems in which the materials will be used.

N-124.1.1 Thermoplastic Piping Components. Table N-102.2.1(A)-1 provides hydrostatic design stresses (HDS) and recommended temperature limits for thermoplastic piping components.

N-124.1.2 Laminated Reinforced Thermosetting Resin Piping Components. Table N-102.2.1(A)-2 provides design stresses (DS) and recommended temperature limits for laminated reinforced thermosetting resin piping components.

N-124.1.3 Machine-Made Reinforced Thermosetting Resin Pipe. Table N-102.2.1(A)-3 provides hydrostatic design basis (HDB) at a temperature level of 73°F for machine-made reinforced thermosetting resin pipe.

N-124.1.4 Notes for Tables N-102.2.1(A)-1, N-102.2.1(A)-2, and N-102.2.1(A)-3. The basis for setting minimum and maximum temperatures varies with the different tables, as noted in the Notes for each table.

N-124.1.5 Upper Temperature Limitations

(A) The maximum design temperature for a listed material shall not exceed maximum temperatures listed in Tables N-102.2.1(A)-1, N-102.2.1(A)-2, and N-102.2.1(A)-3 as applicable, except as provided in para. N-102.3.1.

(B) An unlisted material acceptable under para. N-123.1.2 shall have upper temperature limits established in accordance with para. N-102.2.

N-124.1.6 Lower Temperature Limitations

(A) The minimum design temperature for a listed material shall not be lower than the minimum temperatures listed in Tables N-102.2.1(A)-1 and N-102.2.1(A)-2, as applicable, except as provided in para. N-102.3.1(A).

(B) An unlisted material acceptable under para. N-123.1.2 shall have lower temperature limits established in accordance with the manufacturer's recommendation but in no case less than -20°F .

N-124.9 Installation Limitations for Nonmetallic Piping

N-124.9.1 General

(A) Nonmetallic materials shall be guarded against excessive temperature, shock, vibration, pulsation, and mechanical abuse in all fluid services.

(B) Requirements in this paragraph apply to pressure-containing parts. They do not apply to materials used for supports, gaskets, or packing.

N-124.9.2 Thermoplastics

(A) Thermoplastics shall not be used in flammable fluid service aboveground, unless all of the following are met:

(A.1) The size of the piping does not exceed DN 25 (NPS 1).

(A.2) Owner's approval is obtained.

(B) When used in other than nontoxic, nonflammable, liquid service, thermoplastics shall be installed in a guarded manner that will prevent damage during construction, operation, or service.

(C) PVC and CPVC shall not be used in compressed air or other compressed gas service.

N-124.9.3 Reinforced Thermosetting Resins (RTR) Piping. When used for corrosive, hazardous, or flammable fluid service, RTR piping shall be installed in a guarded manner that will prevent damage during construction, operation, or service.

N-124.9.4 Reinforced Plastic Mortar (RPM) Piping.

When used in other than nontoxic, nonflammable, liquid service, RPM piping shall be installed in a guarded manner that will prevent damage during construction, operation, or service.

N-125 MISCELLANEOUS MATERIALS: JOINING AND AUXILIARY MATERIALS

When selecting materials, e.g., cements, solvents, packing, and O-rings, for making or sealing joints, the designer shall consider their suitability for the fluid service.

Chapter N-IV

Specifications and Standard Data

N-126 MATERIAL SPECIFICATIONS AND STANDARDS

N-126.1 Standard Piping Components

Dimensions of standard piping components shall comply with the standards and specifications listed in Table N-126.1 in accordance with the requirements of para. N-102.2.1. Abbreviations used in this Appendix are listed in para. N-100.2.2.

N-126.2 Nonstandard Piping Components

Where nonstandard piping components are designed in accordance with para. N-104.7, adherence to dimensional standards of ANSI and ASME is strongly recommended where practical. Dimensions of piping connection threads not covered by a governing component specification or standard shall conform to para. N-114.

N-126.3 Reference Documents

(A) The documents listed in Table N-126.1 may contain references to codes, standards, or specifications not listed in the table. Such unlisted codes, standards, or specifications are to be used only in the context of the listed documents in which they appear.

(B) Where documents listed in Table N-126.1 contain design rules that are in conflict with this Appendix, the design rules of this Appendix shall govern.

(C) The fabrication, assembly, examination, inspection, and testing requirements of Chapters N-V and N-VI apply to the construction of piping systems. These requirements are not applicable to the manufacture of material or components listed in Table N-126.1 unless specifically stated.

Table N-126.1 Nonmetallic Material and Product Standards

Standard or Specification	Designation [Notes (1), (2)]
Nonmetallic Fittings	
Threaded Poly(Vinyl Chloride) (PVC) Plastic Pipe Fittings, Schedule 80	ASTM D2464-99 ^{€1}
Poly(Vinyl Chloride) (PVC) Plastic Pipe Fittings, Schedule 40	ASTM D2466-05
Poly(Vinyl Chloride) (PVC) Plastic Pipe Fittings, Schedule 80	ASTM D2467-05
Thermoplastic Gas Pressure Pipe, Tubing, and Fittings	ASTM D2513-04a
Reinforced Epoxy Resin Gas Pressure Pipe and Fittings	ASTM D2517-05
Plastic Insert Fittings for Polyethylene (PE) Plastic Pipe	ASTM D2609-02
Socket-Type Polyethylene Fittings for Outside Diameter-Controlled Polyethylene Pipe and Tubing	ASTM D2683-04
Chlorinated Poly(Vinyl Chloride) (CPVC) Plastic Hot- and Cold-Water Distribution Systems	ASTM D2846-99 ^{€1}
Butt Heat Fusion Polyethylene (PE) Plastic Fittings for Polyethylene (PE) Plastic Pipe and Tubing	ASTM D3261-03
Polybutylene (PB) Plastic Hot- and Cold-Water Distribution Systems	ASTM D3309-96a(2002)
Machine Made "Fiberglass" (Glass-Fiber-Reinforced Thermosetting Resin) Flanges	ASTM D4024-05
"Fiberglass" (Glass-Fiber-Reinforced Thermosetting-Resin) Pressure Pipe Fittings	ASTM D5685-05
Contact-Molded "Fiberglass" (Glass-Fiber-Reinforced Thermosetting Resin) Corrosion Resistant Pipe and Fittings	ASTM D6041-97(2002)
Threaded Chlorinated Poly(Vinyl Chloride) (CPVC) Plastic Pipe Fittings, Schedule 80	ASTM F437-99
Socket-Type Chlorinated Poly(Vinyl Chloride) (CPVC) Plastic Pipe Fittings, Schedule 40	ASTM F438-04
Chlorinated Poly(Vinyl Chloride) (CPVC) Plastic Pipe Fittings, Schedule 80	ASTM F439-05
Electrofusion Type Polyethylene Fittings for Outside Diameter Controlled Polyethylene Pipe and Tubing	ASTM F1055-98 ^{€1}
Special Engineered Fittings, Appurtenances or Valves for use in Poly(Vinyl Chloride) (PVC) or Chlorinated Poly(Vinyl Chloride) (CPVC) Systems	ASTM F1970-05
Nonmetallic Pipe and Tube Products	
Polyethylene Line Pipe	API 15LE-95
Thermoplastic Line Pipe (PVC and CPVC)	API 15LP-87
Low Pressure Fiberglass Line Pipe	API 15LR-01
Concrete Sewer, Storm Drain, and Culvert Pipe	ASTM C14-03
Acrylonitrile-Butadiene-Styrene (ABS) Plastic Pipe, Schedules 40 and 80	ASTM D1527-99(2005)
Poly(Vinyl Chloride) (PVC) Plastic Pipe, Schedules 40, 80, and 120	ASTM D1785-05
Polyethylene (PE) Plastic Pipe, Schedule 40	ASTM D2104-03
Polyethylene (PE) Plastic Pipe (SIDR-PR) Based on Controlled Inside Diameter	ASTM D2239-03
Poly(Vinyl Chloride) (PVC) Pressure-Rated Pipe (SDR Series)	ASTM D2241-04b
Acrylonitrile-Butadiene-Styrene (ABS) Plastic Pipe (SCR-PR)	ASTM D2282-99(2005)
Machine-Made "Fiberglass" (Glass-Fiber-Reinforced Thermosetting-Resin) Pipe	ASTM D2310-01
Polyethylene (PE) Plastic Pipe, Schedules 40 and 80, Based on Outside Diameter	ASTM D2447-03
Thermoplastic Gas Pressure Pipe, Tubing, and Fittings	ASTM D2513-04a
Reinforced Epoxy Resin Gas Pressure Pipe and Fittings	ASTM D2517-05
Joints for IPS PVC Pipe Using Solvent Cement	ASTM D2672-96a(2003)
Polyethylene (PE) Plastic Tubing	ASTM D2737-03
Underground Installation of Thermoplastic Pressure Piping	ASTM D2774-04
Chlorinated Poly(Vinyl Chloride) (CPVC) Plastic Hot- and Cold-Water Distribution Systems	ASTM D2846-99 ^{€1}
Filament-Wound "Fiberglass" (Glass-Fiber-Reinforced Thermosetting-Resin) Pipe	ASTM D2996-01
Centrifugally Cast "Fiberglass" (Glass-Fiber-Reinforced Thermosetting-Resin) Pipe	ASTM D2997-01
Polyethylene (PE) Plastic Pipe (DR-PR) Based on Controlled Outside Diameter	ASTM D3035-03a
Polybutylene (PB) Plastic Hot- and Cold-Water Distribution Systems	ASTM D3309-96a
Chlorinated Poly(Vinyl Chloride) (CPVC) Plastic Pipe, Schedules 40 and 80	ASTM F441-02
Chlorinated Poly(Vinyl Chloride) (CPVC) Plastic Pipe (SDR-PR)	ASTM F442-99
Polyethylene (PE) Plastic Pipe (SDR-PR) Based on Outside Diameter	ASTM F714-05
Plastic-Lined Ferrous Metal Pipe, Fittings, and Flanges	ASTM F1545-97
Pressure-rated Polypropylene (PP) Piping Systems	ASTM F2389-07 ^{€1}
Polyvinyl Chloride (PVC) Pressure Pipe, 4 in. Through 12 in., for Water Distribution	*AWWA C900-97
Polyethylene (PE) Pressure Pipe and Fittings, 4 in. (100 mm) Through 63 in. (1,575 mm), for Water Distribution and Transmission	AWWA C906-99
Fiberglass Pressure Pipe	*AWWA C950-01

Table N-126.1 Nonmetallic Material and Product Standards (Cont'd)

Standard or Specification	Designation [Notes (1), (2)]
Miscellaneous	
Manually Operated Thermoplastic Gas Shutoffs and Valves in Gas Distribution Systems	*ASME B16.40-2008
Standard Test Methods for Vitrified Clay Pipe	ASTM C301-04
Contact-Molded Reinforced Thermosetting Plastic (RTP) Laminates for Corrosion-Resistant Equipment	ASTM C582-02
Standard Terminology Relating to Plastics	ASTM D883-00
Standard Terminology for Abbreviated Terms Relating to Plastics	ASTM D1600-99
Solvent Cement for Acrylonitrile-Butadiene-Styrene (ABS) Plastic Pipe and Fittings	ASTM D2235-04
Determination of External Loading Characteristics of Plastic Pipe by Parallel-Plate Loading	ASTM D2412-02
Solvent Cements for Poly(Vinyl Chloride) (PVC) Plastic Piping Systems	ASTM D2564-04
Heat Fusion Joining of Polyolefin Pipe and Fittings	ASTM D2657-03
Obtaining Hydrostatic Design Basis for Thermoplastic Pipe Materials or Pressure Design Basis for Thermoplastic Pipe Products	ASTM D2837-04
Making Solvent-Cemented Joints With Poly(Vinyl Chloride) (PVC) Pipe and Fittings	ASTM D2855-96(2005)
External Pressure Resistance of "Fiberglass" (Glass-Fiber-Reinforced Thermosetting-Resin) Pipe	ASTM D2924-01
Obtaining Hydrostatic or Pressure Design Basis for "Fiberglass" (Glass-Fiber-Reinforced Thermosetting-Resin) Pipe and Fittings	ASTM D2992-01
Joints for Plastic Pressure Pipes Using Flexible Elastomeric Seals	ASTM D3139-98(2005)
Underground Installation of "Fiberglass" (Glass-Fiber-Reinforced Thermosetting-Resin) Pipe	ASTM D3839-02 ^{€1}
Design and Construction of Nonmetallic Enveloped Gaskets for Corrosive Service	ASTM F336-02
Standard Terminology Relating to Plastic Piping Systems	ASTM F412-07
Solvent Cements for Chlorinated Poly(Vinyl Chloride) (CPVC) Plastic Pipe and Fittings	ASTM F493-04
Electrofusion Joining Polyolefin Pipe and Fittings	ASTM F1290-98a
Taper Pipe Threads 60° for Thermoplastic Pipe and Fittings	ASTM F1498-00 ^{€1}
PVC Pipe — Design and Installation	AWWA M23-02
Fiberglass Pipe Design	AWWA M45-05
Plastic Industrial Ball Valves	MSS SP-122-2005
Plastics Pipe Institute (PPI) Listing of Hydrostatic Design Basis (HDB), Hydrostatic Design Stress (HDS), Strength Design Basis (SDB), Pressure Design Basis (PDB) and Minimum Required Strength (MRS)	PPI TR-4/2006B
Ratings for Thermoplastic Piping Materials or Pipe	
Recommended Design Factors and Design Coefficients for Thermoplastic Pressure Pipe	PPI TR-9/2002
Thermal Expansion and Contraction in Plastics Piping Systems	PPI TR-21/2001

NOTES:

- (1) An asterisk (*) preceding the designation indicates that the standard has been approved as an American National Standard by the American National Standards Institute.
- (2) Numbers in parentheses are reapproval dates.

Chapter N-V

Fabrication, Assembly, and Erection

N-127 BONDING PLASTIC JOINTS

N-127.1 General

N-127.1.1 Bonded joints that conform to this Chapter may be used in accordance with para. N-111.

N-127.1.2 Production joints shall be made only in accordance with a written Bonding Procedure Specification (BPS) that has been qualified in accordance with para. N-127.5.

N-127.1.3 Production joints shall be made only by qualified bonders or bonding operators who have satisfactorily passed a performance qualification test that has been performed in accordance with a written BPS, in accordance with para. N-127.5.

N-127.1.4 Qualification in one BPS does not qualify a bonder or bonding operator for any other bonding procedure.

N-127.1.5 Bonding materials that have been deteriorated by exposure to air or prolonged storage, or that will not spread smoothly, shall not be used.

N-127.1.6 Longitudinal joints are not within the scope of this paragraph.

N-127.1.7 Joint Identification. Each qualified bonder and bonding operator shall be assigned an identification symbol. Unless otherwise specified in the engineering design, each pressure-containing bond or adjacent area shall be stenciled or otherwise suitably marked with the identification symbol of the bonder or bonding operator. Identification stamping shall not be used and any marking paint or ink shall not be detrimental to the piping material. In lieu of marking the bond, appropriate records shall be filed.

N-127.5 Qualification

N-127.5.1 General. Qualification of the BPS to be used, and of the performance of bonders and bonding operators, is required. The BPS shall specify, for both the bonding operation and qualification testing requirements, all required materials, including material storage requirements; the fixtures and tools required, including the care and handling of tools; the environmental (e.g., temperature and humidity) requirements for all operations, including the methods required for measurement; joint preparation requirements; dimensional requirements and tolerances; cure time; protection of work

requirements; tests and examinations other than those required by para. N-127.5.3 (C.2); and acceptance criteria for the completed test assembly.

N-127.5.2 Bonding Responsibility. An employer of bonding personnel is responsible for the bonding done by members of his/her organization and, except as provided in para. N-127.5.3, shall conduct the required performance qualification tests to qualify the BPS(s) and the bonders or bonding operators.

N-127.5.3 Qualification by Others

(A) *BPS.* Each employer (e.g., piping fabricator or erector) shall be responsible for qualifying any BPS that personnel of his/her organization will use. Subject to the specific approval of the owner, a BPS qualified by others may be used if the following conditions apply:

(A.1) The owner, or his/her agent, accepts that the proposed qualified BPS has been prepared and executed by a responsible recognized organization with expertise in the field of bonding.

(A.2) The employer accepts both the BPS and Procedure Qualification Record (PQR) by signature as his/her own.

(A.3) The employer has at least one bonder, currently employed, who has satisfactorily passed a performance qualification test using the proposed qualified BPS.

(B) *Bonding Performance Qualification.* An employer shall not accept a performance qualification test made by a bonder or bonding operator for another employer without the owner's specific approval. If approval is given, acceptance is limited to performance qualification tests on piping using the same or an equivalent BPS. The employer accepting such performance qualification tests shall obtain a copy of the PQR from the previous employer, showing the name of the piping employer by whom bonders or bonding operators were qualified, the dates of such qualification, and the date the bonder or bonding operator last assembled pressure piping under the previous performance qualification.

(C) Qualification tests for the bonding procedure and operator performance shall comply with the requirements of the BPS and the following:

(C.1) A test assembly shall be fabricated in accordance with the Bonding Procedure Specification. The test assembly shall consist of at least one pipe-to-pipe

joint and one pipe-to-fitting joint. The size of the pipe used for the test assembly shall be as follows:

(C.1.1) When the largest size to be joined (within the BPS) is NPS 4 or smaller, the test assembly shall be the same NPS as the largest size to be joined.

(C.1.2) When the largest size to be joined within the BPS is greater than NPS 4, the test assembly shall be made of piping components either NPS 4 or a minimum of 25% of the NPS of the largest piping component to be joined, whichever is larger.

(C.2) The test assembly shall be subjected to one of the following qualification test operations:

(C.2.1) When the test assembly has been cured, it shall be subjected to a hydrostatic pressure test of the maximum of either 150 psig or 1.5 times an equivalent allowable pressure, which shall be calculated using the least nominal wall thickness and outside diameter of the pipe in the test assembly. This pressure shall be determined using the equation in para. N-104.1.2(A) for the test material. The test shall be conducted so that the joint is loaded in both the circumferential and longitudinal directions. Joints shall not leak or separate when tested.

(C.2.2) When a test assembly is joined by heat fusion, the fusion joints may be tested by cutting a minimum of three coupons containing the joint and bending the strips using a procedure that shall be defined in the BPS. As a minimum requirement, the test strips shall not break when bent a minimum of 90 deg, at ambient temperature, over an inside bend radius of 1.5 times the nominal diameter of the tested pipe.

(D) Performance Requalification

(D.1) Renewal of a bonding performance qualification is required when

(D.1.1) a bonder or bonding operator has not used the specific bonding process for a period of time greater than 6 months, or a specific maximum period of time otherwise permitted in the BPS for the work

(D.1.2) there is a specific reason to question a bonder or bonding operator's ability to make bonds that meet the BPS

(D.2) Renewal of a bonding performance qualification for a specific bonding process may be made in only a single test assembly.

N-127.6 Qualification Records

An erector using bonders or bonding operators shall maintain a record of the procedures used and of operators employed by him/her who are qualified in these procedures.

N-127.7 Thermoplastic Pipe Joints

N-127.7.1 Solvent-Cemented Joints

(A) *Preparation.* PVC and CPVC surfaces to be cemented shall be cleaned by wiping with a clean cloth moistened with acetone or methylethyl ketone. Cleaning

Fig. N-127.7.1(B) Solvent-Cemented Joint

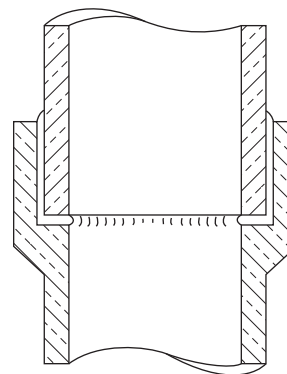

for ABS shall conform to ASTM D2235. Cuts shall be free of burrs and circumferential cuts shall be as square as those obtained by the use of a saw with a miter box or a square-end sawing vise. A slight interference fit between the pipe and a fitting socket is preferred, and the diametral clearance between a pipe and the entrance of a mating socket shall not exceed 0.04 in. This fit shall be checked before solvent cementing.

(B) *Procedure.* Joints shall be made in accordance with a qualified BPS. ASTM D2855 provides a suitable basis for such a procedure. Solvent cements for PVC, CPVC, and ABS shall conform to ASTM D2564, D2846, and D2235, respectively. Cement shall be sufficient to produce a small continuous fillet of cement at the outer limits of the joints. See Fig. N-127.7.1(B).

(C) *Branch Connections.* For branch connections not using a tee, a manufactured full reinforcement saddle with an integral branch socket shall be solvent cemented to the run pipe over its entire contact surface.

(D) *Limitations on Imperfections.* Imperfections exceeding the following limitations are considered defects and shall be repaired and reexamined in accordance with para. N-127.7.3:

(D.1) protrusion of dried cement exceeding 50% of pipe wall thickness into the bore of the pipe

(D.2) unfilled or unbonded areas in a joint, as indicated by the lack of interruption of the continuous fillet noted in (B) above

N-127.7.2 Heat and Fusion Joints

(A) *Preparation.* Surfaces to be heat fused together shall be cleaned of any foreign material. Cuts shall be free of burrs, and circumferential cuts shall be as square as those obtained by the use of a saw with a miter box or a square-end sawing vise.

(B) *Procedure.* Joints shall be made in accordance with a qualified BPS. The general procedures in ASTM D2657, Technique I — Socket Fusion, Technique II — Butt Fusion, and Technique III — Saddle Fusion, provide a suitable basis for such a procedure. Both surfaces to be joined shall be uniformly heated to produce a continuous

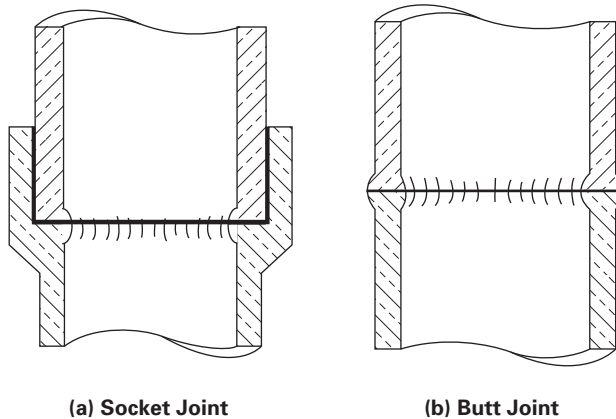
Fig. N-127.7.2(B) Heat Fusion Joints

homogeneous bond between them. This will produce a small continuous fillet of fused material at the outer limits of the joints. See Fig. N-127.7.2(B).

(C) *Branch Connections.* Branch connections shall be made only with the use of molded fittings in sizes that are commercially available.

(D) *Limitations on Imperfections.* Imperfections exceeding the following limitations are considered defects and shall be repaired and reexamined in accordance with para. N-127.7.3:

(D.1) protrusion of fused material exceeding 25% of the pipe wall thickness into the bore of the pipe

(D.2) unfilled or unbonded areas in a joint as indicated by the lack or interruption of the continuous fillet noted in (B) above

N-127.7.3 Electrofusion Joints

(A) *Preparation.* Surfaces to be heat fused together shall be cleaned of all foreign material.

(B) *Procedure.* Joints shall be made in accordance with the qualified BPS. The general procedures in ASTM F1290, Technique 1 — Coupling Procedure and Technique 2 — Saddle Procedure, provide a suitable basis for the development of such a procedure. See Fig. N-127.7.3(B).

N-127.7.4 Repair of Defects. Defective material, joints, and other workmanship in piping that fail to meet the requirements of Chapters N-III and N-V, and of the engineering design, shall be repaired or replaced. Limitations on imperfections, and the method and extent of the required examination of repairs and replacements, shall be the same as for the original work.

N-127.8 FRP Pipe Joints

N-127.8.1 Thermosetting Resin Joints

(A) *Preparation.* Cutting of pipe and preparation of bonding surfaces shall be done as recommended by the manufacturer, without chipping or cracking of the cut ends; particularly, the inner surface of centrifugally cast

pipe. Pipe may be preheated, if necessary, to comply with the above requirements. Cuts shall be free of burrs, and circumferential cuts shall be as square as required by the purchaser's specifications or the recommendations of the manufacturer, whichever requires the closer squareness. For branch connections, holes in the run pipe may be made with a hole saw. Mold-release agent, and any other material that may interfere with adhesion, shall be removed from surfaces to be bonded.

(B) Joining Procedures

(B.1) *Socket and Spigot Joints.* Joints shall be made in accordance with a qualified BPS based on the manufacturer's recommended procedure. Application of adhesive to the surfaces to be joined and assembly of those surfaces shall produce a continuous bond between them. Cut ends of the pipe and edges of the laminate fabric shall be sealed to prevent fluid penetration of the pipe wall or the laminate material. See Fig. N-127.8.1(B).

(B.2) *Butt-and-Wrap Joints.* Joints shall be made in accordance with a qualified BPS. The general procedures in ASTM C582, Contact-Molded Reinforced Thermosetting Plastic (RTP) Laminated for Corrosion Resistant Equipment, provide a suitable basis for the development of such a procedure. Application of plies of reinforcement, saturated with catalyzed resin, to the surfaces to be joined shall produce a continuous structure with the surfaces. Cut ends shall be sealed as required in (B.1) above. See Fig. N-127.8.1(B).

(C) *Branch Connections.* Branch connections shall be made using a manufactured tee fitting or a full reinforcement saddle having suitable provisions for joining as in (B) above. The cut edges of any hole in the run pipe shall be sealed with adhesive at the time the saddle is bonded to the run pipe.

(D) *Limitations on Imperfections.* Imperfections exceeding the following limitations are considered defects and shall be repaired and reexamined in accordance with para. N-127.7.3:

(D.1) protrusion of adhesive exceeding 25% of pipe wall thickness into the bore at the bottom of a socket, or inside a branch connection

(D.2) unfilled or unbonded areas in the joint

N-127.8.2 Repair of Defects. Defective material, joints, and other workmanship in piping that fail to meet the requirements of Chapters N-III and N-V, and of the engineering design, shall be repaired or replaced. Limitations on imperfections, and the method and extent of the required examination of repairs and replacements, shall be the same as for the original work.

N-127.9 Welding of Metallic Piping Lined With Nonmetals

Welding is not permitted on lined components in the field. Welding performed by the manufacturer to produce pipe, fittings, and flanges to be used in an elastomeric lined piping system shall conform to the

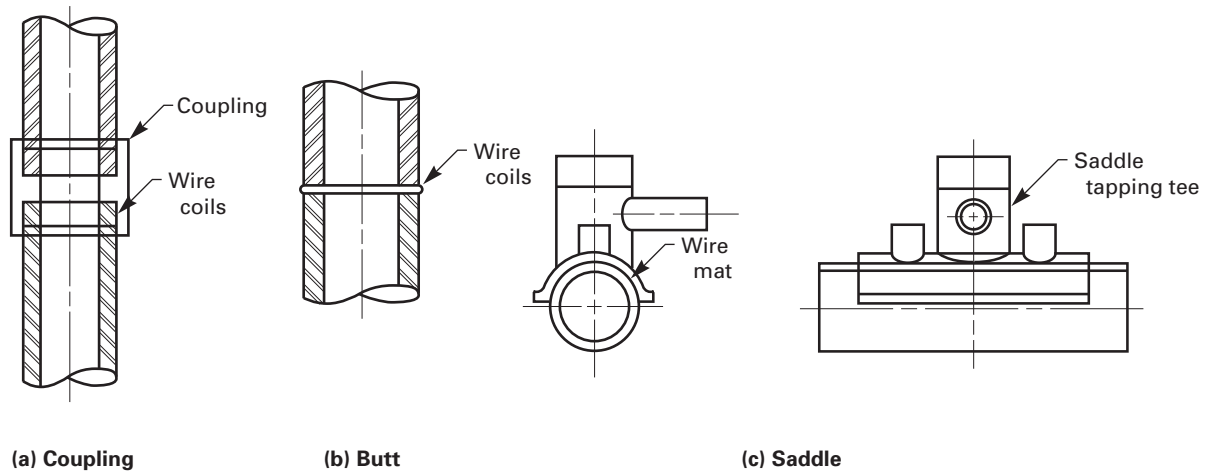
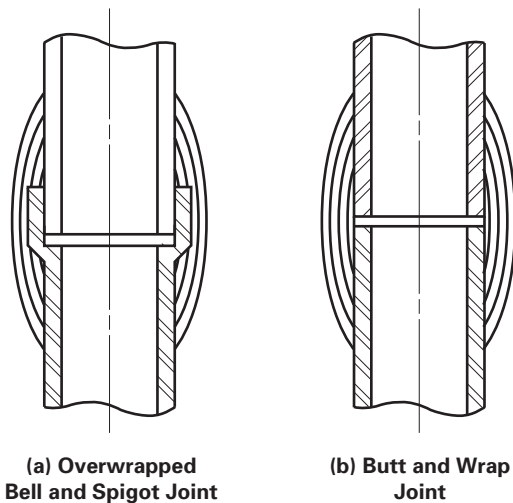
Fig. N-127.7.3(B) Thermoplastic Electrofusion Joints**Fig. N-127.8.1(B) Thermosetting Resin Joints**

requirements of ASME BPVC Section IX and shall be performed so as to maintain the continuity of the lining and its serviceability.

N-129 BENDING AND FORMING

N-129.1 Bending

N-129.1.1 Pipe Bending. Flattening of a bend is defined as the difference between the maximum and minimum outside diameters, at any cross section, expressed as a percentage of the nominal outside diameter. Flattening shall not exceed 8% for pipe exposed to internal pressure. For pipe under external pressure, flattening shall not exceed 3%. The thickness after bending shall be not less than that required in para. N-104.2.

N-129.1.2 Bending Methods. Pipe may be bent by any suitable hot or cold method permissible by radii limitations and material characteristics of the pipe being

bent. Hot bending shall be done within a temperature range consistent with material characteristics, end-use requirements, and the pipe manufacturer's recommendations.

N-129.2 Component Forming

Piping components may be formed by any suitable hot or cold method permissible by the characteristics of the material being formed. Forming shall be done within a temperature range consistent with the material characteristics, end-use requirements, and the component manufacturer's recommendations. The thickness after forming shall be not less than that required by the engineering design.

N-135 ASSEMBLY AND ERECTION

N-135.1 General

The assembly and erection of nonmetallic piping systems shall comply with the requirements of para. 135 of the Code and Chapter N-V of this Appendix. In addition,

(A) when assembling nonmetallic flanges, flat washers shall be used under all bolt heads and nuts. The specified maximum bolt torque shall not be exceeded.

(B) full circumference wrenches shall be used to tighten threaded pipe joints. Tools and other devices used to hold or apply forces to the pipe shall be such that pipe surfaces are not scored or deeply scratched. For thermosetting resin piping, threads shall be coated with sufficient adhesive to cover the threads and completely fill the clearance between the pipe and fittings.

N-135.3 Bolted Flanged Connections

N-135.3.5 Flaring of Nonmetallic Linings

(A) *General.* The provisions of this paragraph apply to metallic pipe lined with plastic or other flexible material. To prevent the fluid from contacting the metallic piping where the lining must be interrupted at a

field-installed flanged joint, the metal piping shall be trimmed so that the end of the lining projects beyond the face of the flange. The projecting lining shall then be flared back so that it covers a portion of the flange face, in a manner similar to a lap joint. When the flange is made up, the corresponding flared ends shall be pressed together, forming a seal.

(A.1) This paragraph applies only to the flaring of linings in pipe that has previously been lined with nonmetals.

(A.2) Flaring that conforms to this paragraph may be used in accordance with para. N-115(B).

(A.3) Flaring shall be performed only in accordance with a written flaring procedure specification, and only by qualified operators who have appropriate training or experience in the use of the applicable flaring procedures.

Chapter N-VI

Examination, Inspection, and Testing

N-136 GENERAL

The general requirements of Chapter VI with regard to visual examination and leak testing are basically applicable to nonmetallic piping systems.

N-136.1 Inspection

The distinction between “Inspection” and “Examination” discussed in para. 136.1.1 applies for piping covered by this Appendix.

N-136.3 Examination

N-136.3.1 General. Examination denotes the functions performed by the manufacturer, fabricator, erector, or a party authorized by the owner. Nondestructive examinations (NDE) shall be by visual examination and other methods suitable for the type of nonmetallic piping being examined. The degree of examination and the acceptance standards beyond the requirements of this Code shall be a matter of prior agreement between the manufacturer, fabricator, or erector and the owner.

N-136.3.2 Qualification of NDE Personnel. Personnel who perform nondestructive examination of bonds shall be qualified and certified for each examination method in accordance with a program established by their employer. The program shall be based on the following minimum requirements:

(A) instruction in the fundamentals of the nondestructive examination method.

(B) on-the-job training to familiarize the NDE personnel with the appearance and interpretation of indications of bond defects. The length of time for such training shall be sufficient to ensure adequate assimilation of the knowledge required.

(C) an eye examination, performed at least once each year, to determine optical capability of NDE personnel to perform the required examination.

(D) upon completion of (A) and (B) above, the NDE personnel shall be given an oral or written examination and performance examination by the employer, to determine if the NDE personnel are qualified to perform the required examination and interpretation of results.

(E) certified NDE personnel whose work has not included performance of a specific examination method for a period of 1 yr or more shall be recertified by successfully completing the examination of (D) above and also

passing the visual examination of (C) above. Substantial changes in procedures or equipment shall require recertification of NDE personnel.

N-136.3.3 Extent of Required Examination. When visual examination reveals a defect requiring repair,

(A) two additional examinations of the same type shall be made of the same kind of item (if of a bond, others by the same bonder or bonding operator) and

(B) if the additional items examined as required by (A) above are acceptable, the item requiring repair shall be replaced or repaired and reexamined to meet the requirements of the Code, and all items represented by this additional examination shall be accepted, or

(C) if either of the items examined as required by (A) above reveals a defect, two additional items shall be examined, and

(D) if the additional items examined as required by (C) above are acceptable, the items requiring repair shall be replaced or repaired and reexamined to meet the requirements of the Code, and all items represented by this additional examination shall be accepted, or

(E) if either of the additional items examined as required by (C) above reveals a defect, all comparable items shall be replaced or they shall be fully examined, and all items requiring repair shall be repaired and reexamined to meet the requirements of the Code

N-136.4 Examination Methods

N-136.4.1 Nondestructive Examination

(A) Piping shall be examined at least to the extent required herein, or to any greater extent specified in the engineering design.

(A.1) Visually examine at least 5% of fabrication. For bonds (joints), each bonder or bonding operator’s work shall be represented and shall include each type of bond for each bonder or bonding operator.

(A.2) Visually examine 100% of fabrication for bonds, other than circumferential bonds, and other than those in components made to material specifications recognized in this Code.

(A.3) Perform a random visual examination of the assembly of threaded, bolted, and other joints to satisfy the inspector that these conform to the requirements of para. N-135.

(A.4) Perform a random visual examination during erection of piping, including checking of alignment and supports.

Table N-136.4.1(B) Acceptance Criteria for Bonds

Kind of Imperfection	Thermoplastic		RTR and RPM [Note (1)], Adhesive Cemented
	Solvent Cemented	Heat Fusion	
Cracks	Not applicable	Not applicable	Not applicable
Unfilled areas in joint	None permitted	None permitted	None permitted
Unbonded areas in joint	None permitted	None permitted	None permitted
Inclusions of charred material	Not applicable	Not applicable	Not applicable
Unfused filler material inclusions	Not applicable	Not applicable	Not applicable
Protrusion of material into pipe bore, % of pipe wall thickness	Cement, 50%	Fused material, 25%	Adhesive, 25%

NOTE:

(1) RTR = reinforced thermosetting resin; RPM = reinforced plastic mortar.

(A.5) Examine erected piping for evidence of damage that would require repair or replacement and for other deviations from the design.

(B) Minimum acceptance criteria shall be as indicated in Table N-136.4.1(B).

(C) The inspector shall be assured, by examination of certifications, records, or other evidence, that the materials and components are of the specified grades and that they have received the required examination and testing.

(D) When examination reveals a defect requiring repair,

(D.1) two additional examinations of the same type shall be made of the same kind of item (if of a bond, others by the same bonder or bonding operator), and

(D.2) if the additional items examined as required by (D.1) above are acceptable, the item requiring repair shall be replaced or repaired and reexamined to meet the requirements of the Code, and all items represented by this additional examination shall be accepted, or

(D.3) if either of the items examined as required by (D.1) above reveals a defect, two additional items shall be examined, and

(D.4) if the additional items examined as required by (D.3) above are acceptable, the items requiring repair

shall be replaced or repaired and reexamined to meet the requirements of the Code, and all items represented by this additional examination shall be accepted, or

(D.5) if either of the additional items examined as required by (D.3) above reveals a defect, all comparable items shall be replaced or they shall be fully examined, and all items requiring repair shall be repaired and reexamined to meet the requirements of the Code

N-136.4.2 Visual Examination

(A) Visual examination consists of observation of the portion of components, joints, and other piping elements that are, or can be, exposed to view before, during, or after manufacture, fabrication, assembly, erection, inspection, or testing.

(B) Visual examination shall be performed in accordance with Article 9, Section V of the ASME Boiler and Pressure Vessel Code.

N-137 PRESSURE TESTS

Leak tests, when specified, shall be performed in accordance with para. 137.

NONMANDATORY APPENDICES

NONMANDATORY APPENDIX II RULES FOR THE DESIGN OF SAFETY VALVE INSTALLATIONS¹

FOREWORD

ASME B31.1 contains rules governing the design, fabrication, materials, erection, and examination of power piping systems. Experience over the years has demonstrated that these rules may be reasonably applied to safety valve installations. Nevertheless, instances have occurred wherein the design of safety valve installations may not have properly and fully applied the ASME B31.1 rules. Accordingly, this Appendix to ASME B31.1 has been prepared to illustrate and clarify the application of ASME B31.1 rules to safety valve installations. To this end, this Appendix presents the designer with design guidelines and alternative design methods.

II-1 SCOPE AND DEFINITION

II-1.1 Scope

The scope of this Appendix is confined to the design of the safety valve installations as defined in para. II-1.2. The loads acting at the safety valve station will affect the bending moments and stresses in the complete piping system, out to its anchors and/or extremities, and it is the designer's responsibility to consider these loads. This Appendix, however, deals primarily with the safety valve installation, and not the complete piping system.

The design of the safety valve installation requires that careful attention be paid to

- (A) all loads acting on the system
- (B) the forces and bending moments in the piping and piping components resulting from the loads
- (C) the loading and stress criteria
- (D) general design practices

All components in the safety valve installation must be given consideration, including the complete piping system, the connection to the main header, the safety valve, valve and pipe flanges, the downstream discharge

or vent piping, and the system supports. The scope of this Appendix is intended to cover all loads on all components. It is assumed that the safety valve complies with the requirements of American National Standards prescribed by ASME B31.1 for structural integrity.

This Appendix has application to either safety, relief, or safety-relief valve installations. For convenience, however, the overpressure protection device is generally referred to as a safety valve. The loads associated with relief or safety-relief valve operation may differ significantly from those of safety valve operation, but otherwise the rules contained herein are equally applicable to each type of valve installation. See para. II-1.2 for definition.

This Appendix provides analytic and nomenclature definition figures to assist the designer, and is not intended to provide actual design layout (drains, drip pans, suspension, air gaps, flanges, weld ends, and other design details are not shown). Sample problems have been provided at the end of the text to assist the designer in application of the rules in this Appendix.

II-1.2 Definitions (Valve Descriptions Follow the Definitions Given in Section I of the ASME Boiler and Pressure Vessel Code)

safety valve: an automatic pressure-relieving device actuated by the static pressure upstream of the valve and characterized by full opening pop action. It is used for gas or vapor service.

relief valve: an automatic pressure-relieving device actuated by the static pressure upstream of the valve that opens further with the increase in pressure over the opening pressure. It is used primarily for liquid service.

safety relief valve: an automatic pressure-actuated relieving device suitable for use either as a safety valve or relief valve, depending on application.

¹ Nonmandatory appendices are identified by a Roman numeral; mandatory appendices are identified by a letter. Therefore, Roman numeral I is not used, in order to avoid confusion with the letter I.

power-actuated pressure-relieving valve: a relieving device whose movements to open or close are fully controlled by a source of power (electricity, air, steam, or hydraulic). The valve may discharge to atmosphere or to a container at lower pressure. The discharge capacity may be affected by the downstream conditions, and such effects shall be taken into account. If the power-actuated pressure-relieving valves are also positioned in response to other control signals, the control impulse to prevent overpressure shall be responsive only to pressure and shall override any other control function.

open discharge installation: an installation where the fluid is discharged directly to the atmosphere or to a vent pipe that is uncoupled from the safety valve. Figure II-1.2(A) shows a typical open discharge installation with an elbow installed at the valve discharge to direct the flow into a vent pipe. The values for l and m on Fig. II-1.2(A) are upper limits for which the rules for open discharge systems may be used. l shall be limited to a value less than or equal to $4D_o$; m shall be limited to a value less than or equal to $6D_o$ where D_o is the outside diameter of the discharge pipe. Open discharge systems which do not conform to these limits shall be evaluated by the designer for the applicability of these rules.

closed discharge installation: an installation where the effluent is carried to a distant spot by a discharge pipe which is connected directly to the safety valve. Figure II-1.2(B) shows a typical closed discharge system.

safety valve installation: the safety valve installation is defined as that portion of the system shown on Fig. II-1.2(A) and Fig. II-1.2(B). It includes the run pipe, branch connection, the inlet pipe, the valve, the discharge piping, and the vent pipe. Also included are the components used to support the system for all static and dynamic loads.

II-2 LOADS

II-2.1 Thermal Expansion

Loads acting on the components in the safety valve installation and the displacements at various points due to thermal expansion of the piping shall be determined by analyzing the complete piping system out to its anchors, in accordance with procedures in para. 119.

II-2.1.1 Installations With Open Discharge. For safety valve installations with open discharge, there will be no thermal expansion loads acting on the discharge elbow, the valve, or the valve inlet other than that from restraint to thermal expansion as described below. Restraint to thermal expansion can sometimes occur due to drain lines, or when structural supports are provided to carry the reaction forces associated with safety valve lift. Examples of such structural supports are shown in Fig. II-6-1, illustration (b). When such restraints exist, the

thermal expansion loads and stresses shall be calculated and effects evaluated.

II-2.1.2 Installations With Closed Discharge. Loads due to thermal expansion and back pressure of a safety valve installation with a closed discharge can be high enough to cause malfunction of the valve, excessive leakage of the valve or flange, or overstress of other components. The loads due to thermal expansion shall be evaluated for all significant temperature combinations, including the cases where the discharge piping is hot following safety valve operation.

II-2.2 Pressure

Pressure loads acting on the safety valve installation are important from two main considerations. The first consideration is that the pressure acting on the walls of the safety valve installation can cause membrane stresses which could result in rupture of the pressure-retaining parts. The second consideration is that the pressure effects associated with discharge can cause high loads acting on the system which create bending moments throughout the piping system. These pressure effects are covered in para. II-2.3.

All parts of the safety valve installation must be designed to withstand the design pressures without exceeding the Code allowable stresses. The branch connection, the inlet pipe, and the inlet flanges shall be designed for the same design pressure as that of the run pipe. The design pressure of the discharge system will depend on the safety valve rating and on the configuration of the discharge piping. The open discharge installation and the closed discharge installation present somewhat different problems in the determination of design pressures, and these problems are discussed in the paragraphs below.

II-2.2.1 Design Pressure and Velocity for Open Discharge Installation Discharge Elbows and Vent Pipes.

There are several methods available to the designer for determining the design pressure and velocity in the discharge elbow and vent pipe. It is the responsibility of the designer to assure himself that the method used yields conservative results. A method for determining the design pressures and velocities in the discharge elbow and vent pipe for open discharge installation is shown below and illustrated in the sample problem.

(A) First, calculate the design pressure and velocity for the discharge elbow.

(A.1) Determine the pressure, P_1 , that exists at the discharge elbow outlet (Fig. II-2-1).

$$P_1 = \frac{W}{A_1} \frac{(b-1)}{b} \sqrt{\frac{2(h_o - a)l}{g_c(2b-1)}}$$

Fig. II-1.2(A) Safety Valve Installation (Open Discharge System)

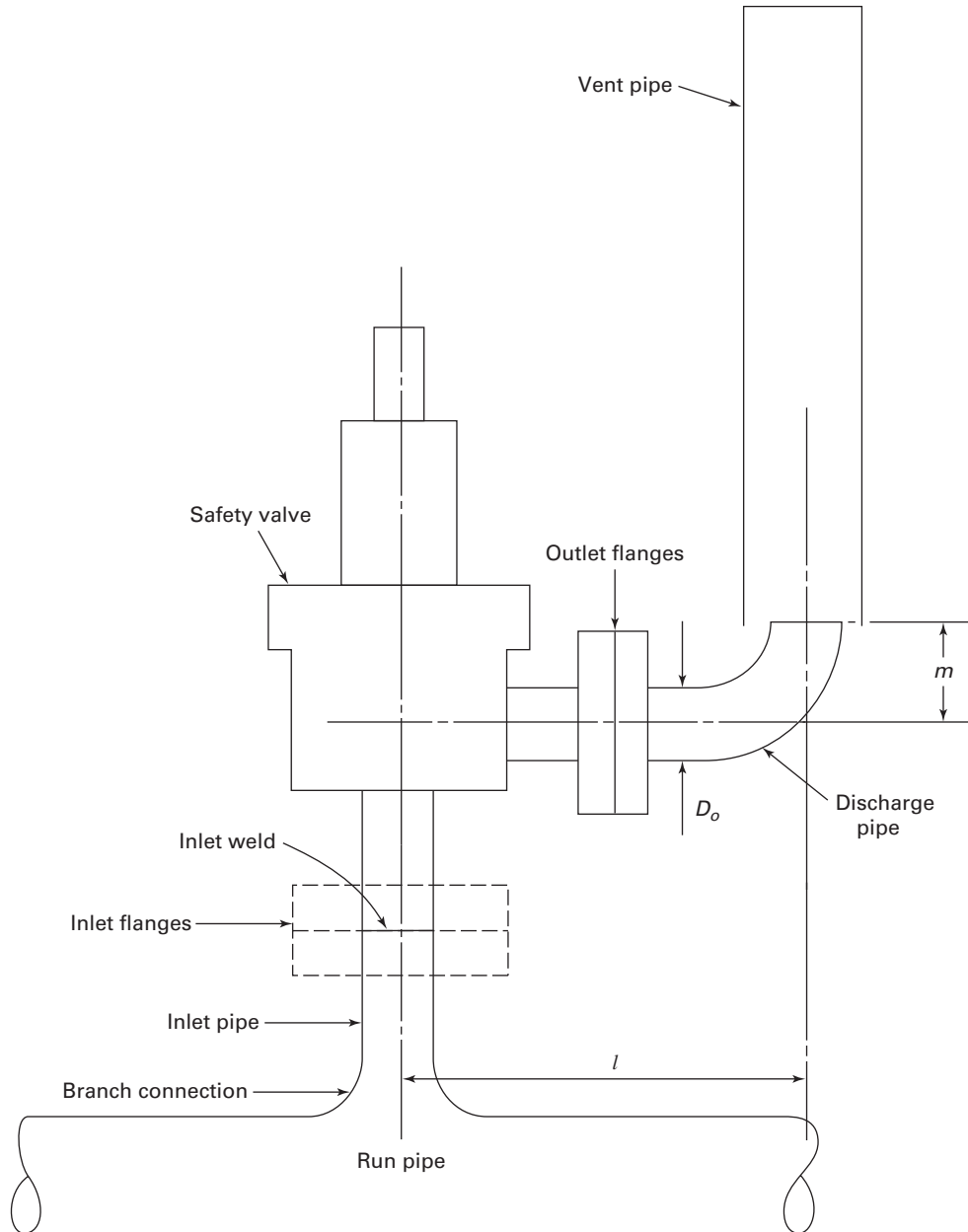

Fig. II-1.2(B) Safety Valve Installation (Closed Discharge System)

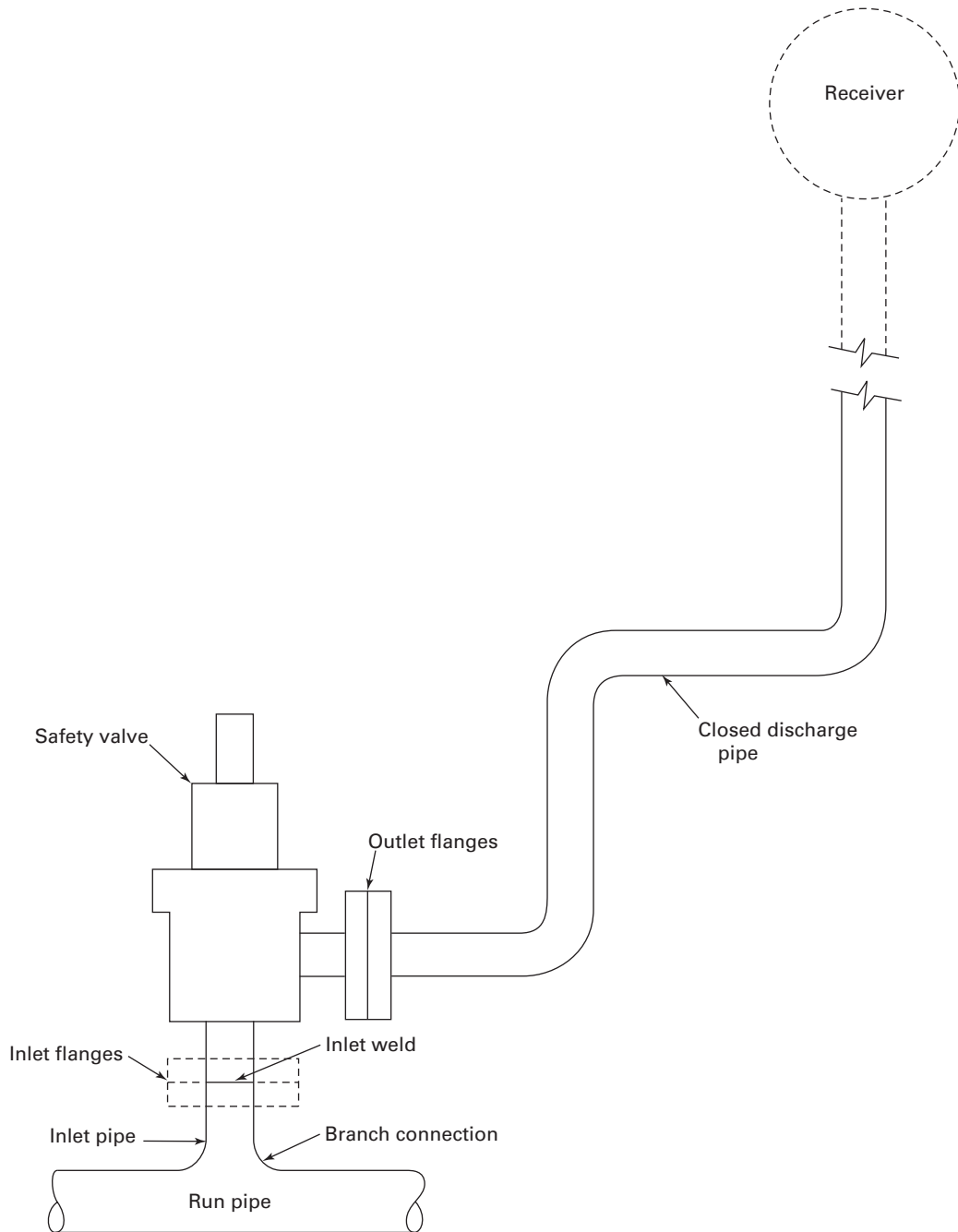
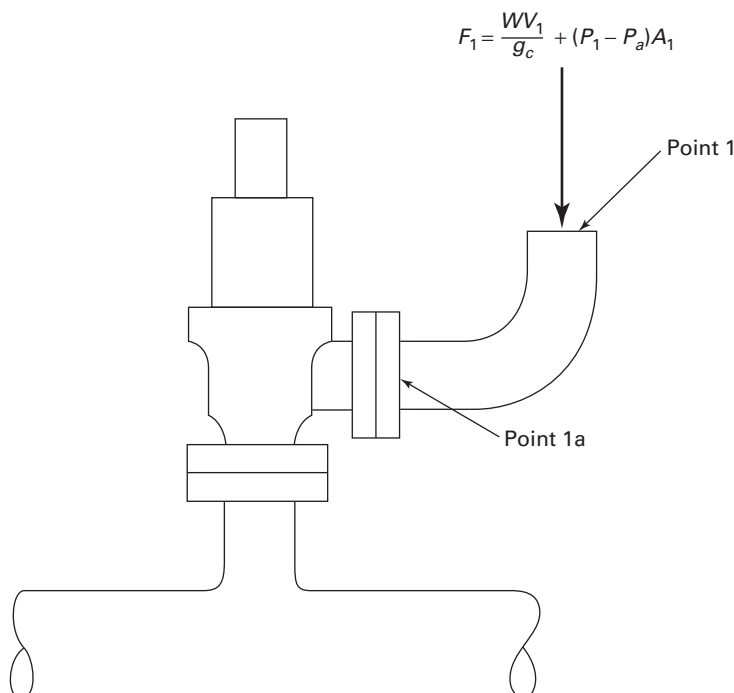

Fig. II-2-1 Discharge Elbow (Open Discharge Installation)

(A.2) Determine the velocity, V_1 , that exists at the discharge elbow outlet (Fig. II-2-1).

$$V_1 = \sqrt{\frac{2g_c J(h_o - a)}{(2b - 1)}}$$

where

A_1 = discharge elbow area, in.²

g_c = gravitational constant
= 32.2 lbm-ft/lbf-sec²

h_o = stagnation enthalpy at the safety valve inlet,
Btu/lbm

J = 778.16 ft-lbf/Btu

P_1 = pressure, psia (lbf/in.², absolute)

V_1 = velocity, ft/sec

W = actual mass flow rate, lbm/sec

Common values of a and b are listed in Table II-2.2.1.

(A.3) Determine the safety valve outlet pressure, P_{1a} , at the inlet to the discharge elbow (Fig. II-2-1).

(A.3.1) Determine the length to diameter ratio (dimensionless) for the pipe sections in the discharge elbow (L/D).

$$L/D = \frac{L_{\max}}{D}$$

(A.3.2) Determine a Darcy-Weisbach friction factor, f , to be used. (For steam, a value of 0.013 can be used as a good estimate since f will vary slightly in turbulent pipe flow.)

Table II-2.2.1 Values of a and b

Steam Condition	a , Btu/lbm	b
Wet steam, < 90% quality	291	11
Saturated steam, ≥ 90% quality, 15 psia ≤ P_1 ≤ 1,000 psia	823	4.33
Superheated steam, ≥ 90% quality, 1,000 psia < P_1 ≤ 2,000 psia ¹	831	4.33

NOTE:

(1) This method may be used as an approximation for pressures over 2,000 psi, but an alternate method should be used for verification.

(A.3.3) Determine a specific heat ratio (for superheated steam, $k = 1.3$ can be used as an estimate — for saturated steam, $k = 1.1$).

(A.3.4) Calculate $f(L_{\max}/D)$.

(A.3.5) Enter Chart II-1 with value of $f(L_{\max}/D)$ and determine P/P^* .

(A.3.6) $P_{1a} = P_1 (P/P^*)$.

(A.3.7) P_{1a} is the maximum operating pressure of the discharge elbow.

(B) Second, determine the design pressure and velocity for the vent pipe.

Chart II-1 Compressible Flow Analysis

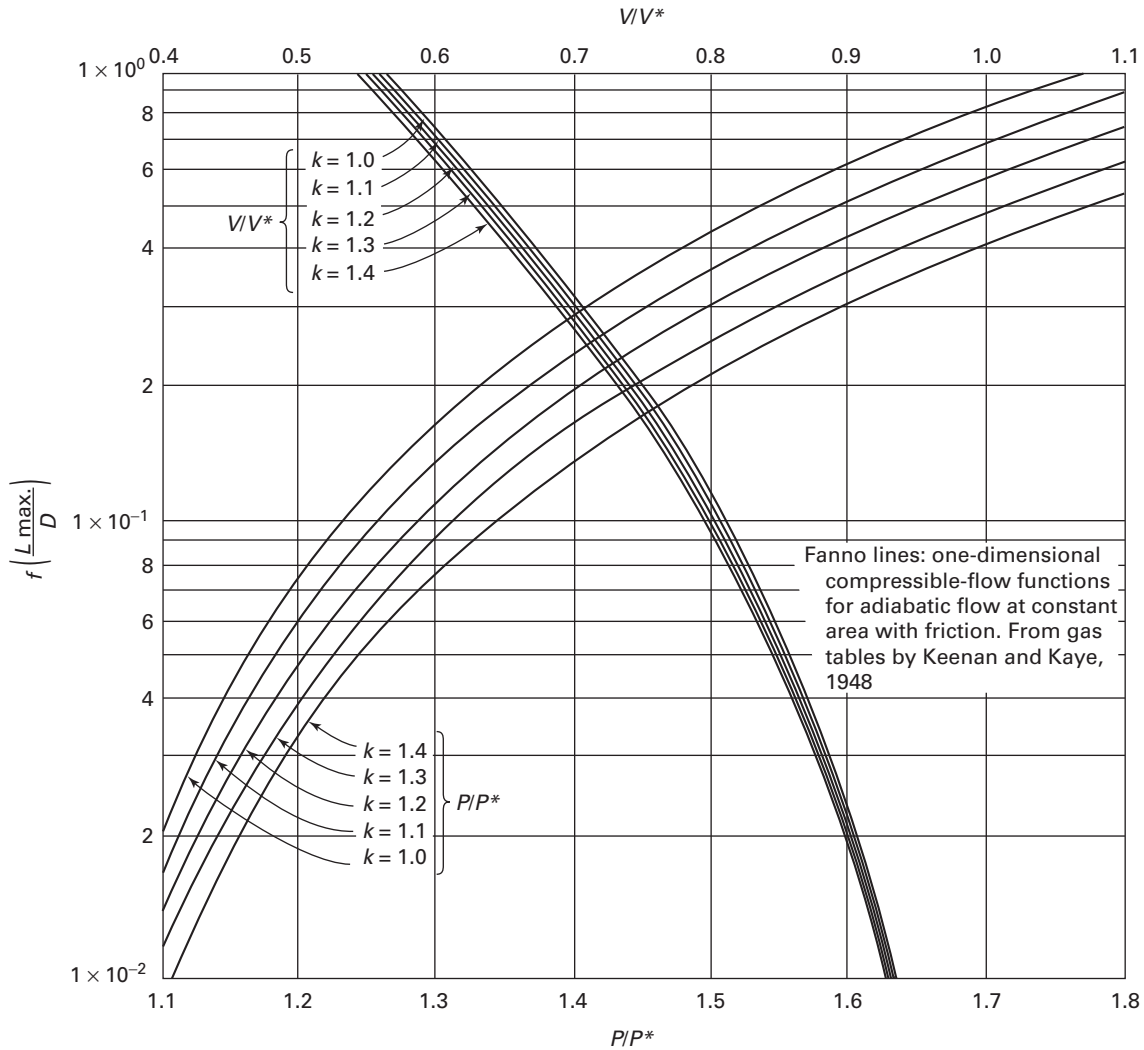

(B.1) Determine the pressure, P_3 , that exists at the vent pipe outlet (Fig. II-2-2).

$$P_3 = P_1 \left(\frac{A_1}{A_3} \right)$$

(B.2) Determine the velocity, V_3 , that exists at the vent pipe outlet (Fig. II-2-2).

$$V_3 = V_1$$

(B.3) Repeat Steps (A.3.1) to (A.3.7) in the calculation of the discharge elbow maximum operating pressure to determine the maximum operating pressure of the vent pipe.

(B.4) Determine the velocity, V_2 , and pressure, P_2 , that exist at the inlet to the vent pipe (Fig. II-2-2).

(B.4.1) Enter Chart II-1² with value of $f(L_{\max}/D)$ from Step (3.4) and determine values of V/V^* and P/P^* .

(B.4.2) Calculate V_2 .

$$V_2 = V_3 (V/V^*)$$

(B.4.3) $P_2 = P_3 (P/P^*)$. This is the highest pressure the vent stack will see and should be used in calculating vent pipe blowback (see para. II-2.3.1.2).

II-2.2.2 Pressure for Closed Discharge Installations.

The pressures in a closed discharge pipe during steady

² Chart II-1 may be extended to other values of $f(L_{\max}/D)$ by use of the Keenan and Kaye Gas Tables for Fanno lines. The Darcy-Weisbach friction factor is used in Chart II-1, whereas the Gas Tables use the Fanning factor, which is one-fourth the value of the Darcy-Weisbach factor.

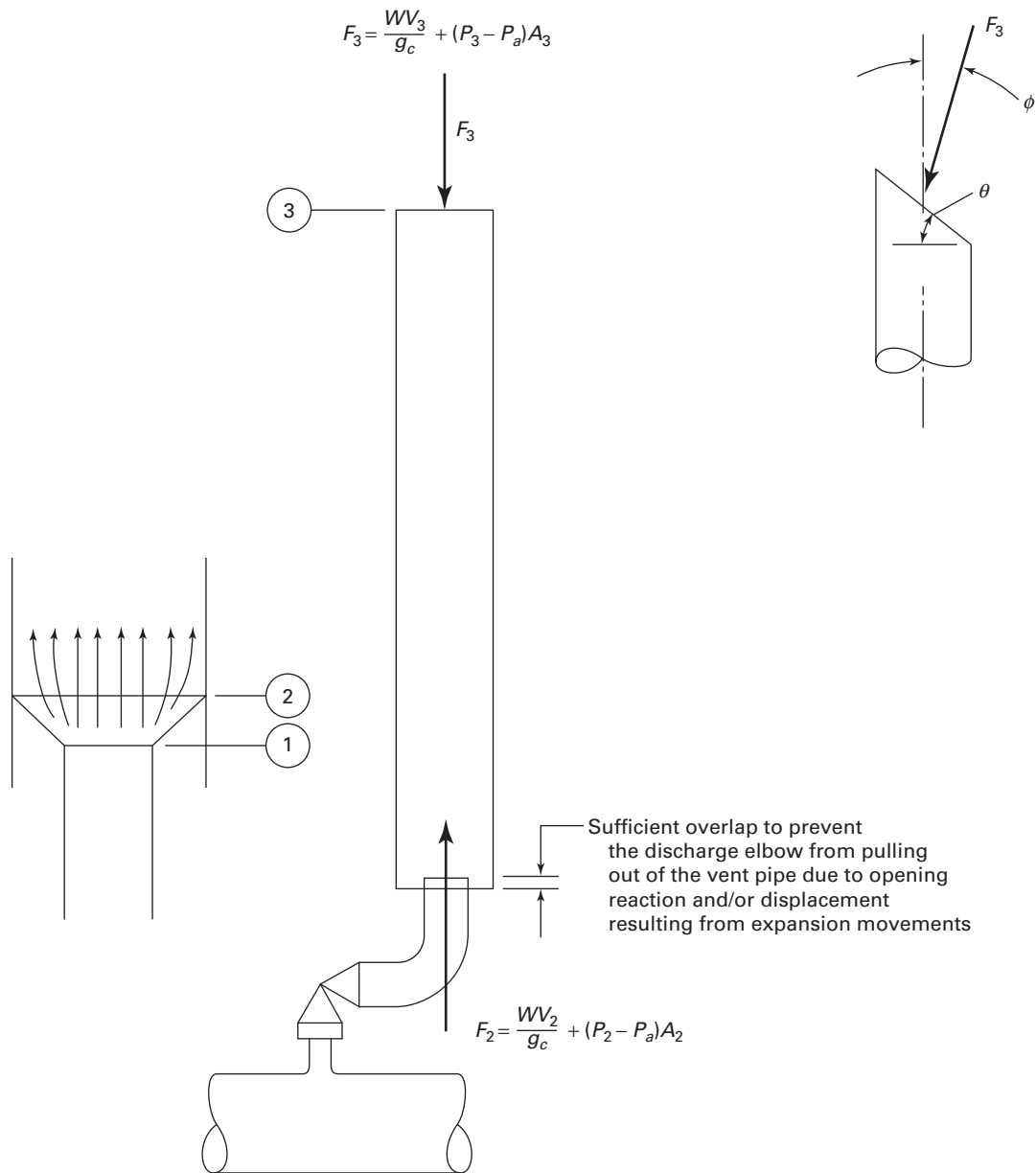
Fig. II-2-2 Vent Pipe (Open Discharge Installation)

state flow may be determined by the methods described in para. II-2.2.1. However, when a safety valve discharge is connected to a relatively long run of pipe and is suddenly opened, there is a period of transient flow until the steady state discharge condition is reached. During this transient period, the pressure and flow will not be uniform. When the safety valve is initially opened, the discharge pipe may be filled with air. If the safety valve is on a steam system, the steam discharge from the valve must purge the air from the pipe before steady state steam flow is established and, as the pressure builds up at the valve outlet flange and waves start to travel down the discharge pipe, the pressure wave

initially emanating from the valve will steepen as it propagates, and it may steepen into a shock wave before it reaches the exit. Because of this, it is recommended that the design pressure of the closed discharge pipe be greater than the steady state operating pressure by a factor of at least 2.

II-2.3 Reaction Forces From Valve Discharge

It is the responsibility of the piping system designer to determine the reaction forces associated with valve discharge. These forces can create bending moments at various points in the piping system so high as to cause catastrophic failure of the pressure boundary parts. Since

the magnitude of the forces may differ substantially, depending on the type of discharge system, each system type is discussed in the paragraphs below.

II-2.3.1 Reaction Forces With Open Discharge Systems

II-2.3.1.1 Discharge Elbow. The reaction force, F , due to steady state flow following the opening of the safety valve includes both momentum and pressure effects. The reaction force applied is shown in Fig. II-2-1, and may be computed by the following equation:

$$F_1 = \frac{W}{g_c} V_1 + (P_1 - P_a) A_1$$

where

- A_1 = exit flow area at Point 1, in.²
- F_1 = reaction force at Point 1, lbf
- g_c = gravitational constant
= 32.2 lbf-ft/lbf-sec²
- P_1 = static pressure at Point 1, psia
- P_a = atmospheric pressure, psia
- V_1 = exit velocity at Point 1, ft/sec
- W = mass flow rate (relieving capacity stamped on the valve \times 1.11), lbfm/sec

To ensure consideration of the effects of the suddenly applied load F , a dynamic load factor, DLF , should be applied (see para. II-3.5.1.3).

The methods for calculating the velocities and pressures at the exit point of the discharge elbow are the same as those discussed in para. II-2.2 of this Appendix.

II-2.3.1.2 Vent Pipe. Figure II-2-2 shows the external forces resulting from a safety valve discharge, which act on the vent pipe. The methods for calculating F_2 and F_3 are the same as those previously described. The vent pipe anchor and restraint system must be capable of taking the moments caused by these two forces, and also be capable of sustaining the unbalanced forces in the vertical and horizontal directions.

A bevel of the vent pipe will result in a flow that is not vertical. The equations shown are based on vertical flow. To take account for the effect of a bevel at the exit, the exit force will act at an angle, ϕ , with the axis of the vent pipe discharge which is a function of the bevel angle, θ . The beveled top of the vent deflects the jet approximately 30 deg off the vertical for a 60 deg bevel, and this will introduce a horizontal component force on the vent pipe systems.

The terms in the equations shown on Fig. II-2-2 are the same as those defined in para. II-2.3.1 above.

The vent pipe must be sized so that no steam is blown back at the vent line entrance. The criteria that may be used as a guide to prevent this condition are listed below.

$$\frac{W(V_1 - V_2)}{g_c} > (P_2 - P_a) A_2 - (P_1 - P_a) A_1$$

where

- A = area, in.²
- g_c = gravitational constant
= 32.2 lbfm-ft/lbf-sec²
- P_1, P_2 = local absolute pressure, psia
- P_a = standard atmospheric pressure, psia
- V = velocity, ft/sec
- W = mass flow rate, lbfm/sec

The inequality states that the momentum at Point 1 has to be greater than the momentum at Point 2 in order that air is educted into the vent pipe. If the momentum at Point 1 equalled the momentum at Point 2, no air would be educted into the vent pipe. If the momentum at Point 1 was less than the momentum at Point 2, steam would "blow back" from the vent pipe.

The educting effect of the vent pipe is especially important for indoor installation of safety valves. The steam being vented from the upper body during safety valve operation will be removed from the area through the vent pipe. For that reason, the fluid momentum at 1 should exceed the fluid momentum at 2, not just be equal.

If this inequality is satisfied, blowback will not occur. The pressures and velocities are those calculated in para. II-2.2.1.

II-2.3.2 Reaction Forces With Closed Discharge Systems.

When safety valves discharge a closed piping system, the forces acting on the piping system under steady state flow will be self-equilibrated, and do not create significant bending moments on the piping system. The large steady state force will act only at the point of discharge, and the magnitude of this force may be determined as described for open discharge systems.

Relief valves discharging into an enclosed piping system create momentary unbalanced forces which act on the piping system during the first few milliseconds following relief valve lift. The pressure waves traveling through the piping system following the rapid opening of the safety valve will cause bending moments in the safety valve discharge piping and throughout the remainder of the piping system. In such a case, the designer must compute the magnitude of the loads, and perform appropriate evaluation of their effects.

II-2.4 Other Mechanical Loads

Other design mechanical loads that must be considered by the piping designer include the following:

II-2.4.1 Interaction loads on the pipe run when more than one valve opens.

II-2.4.2 Loads due to earthquake and/or piping system vibration (see para. II-3.4).

II-3 BENDING MOMENT COMPUTATIONS

II-3.1 General

One of the most important considerations related to the mechanical design and analysis of safety valve installation is the identification and calculation of the moments at critical points in the installation. If the bending moments are not properly calculated, it will not be possible to meet the loading and stress criteria contained in ASME B31.1. As a minimum, the following loads, previously discussed in para. II-2 of this Appendix, should be considered in determining these moments:

- (A) thermal expansion
- (B) deadweight
- (C) earthquake
- (D) reaction force from valve discharge
- (E) other mechanical loads

The analysis of the safety valve installation should include all critical sections, such as intersection points, elbows, transition sections, etc., and any related piping, vessels, and their supports that may interact with the safety valve installation. It is often most appropriate to model the safety valve installation and its related piping as a lumped mass system joined by straight or curved elements.

II-3.2 Thermal Expansion Analysis

There are many standard and acceptable methods for determination of moments due to thermal expansion of the piping installation. The thermal expansion analysis must comply with the requirements in para. 119. The safety valve installation often presents a special problem in that there may be a variety of operational modes to consider where each mode represents a different combination of temperatures in various sections of the piping system. The design condition shall be selected so that none of the operational modes represents a condition that gives thermal expansion bending moments greater than the design condition.

The design of the safety valve installation should consider the differential thermal growth and expansion loads, as well as the local effects of reinforcing and supports. The design should also consider the differential thermal growth and expansion loads existing after any combination of safety valves (one valve to all valves) operates, raising the temperature of the discharge piping.

II-3.3 Deadweight Analysis

The methods used for determination of bending moments due to deadweight in a safety valve installation are not different from the methods used in any other piping installation. If the support system meets the requirements in para. 121, the bending moments due to deadweight may be assumed to be $1,500Z$ (in.-lb) where Z is the section modulus (in.³) of the pipe or fitting being considered. However, bending moments due to

deadweight are easily determined and should always be calculated in systems where stresses exceed 90% of the allowable stress limits in meeting the requirements of eqs. (15) and (16) of para. 104.8.

II-3.4 Earthquake Analysis

Seismic loads must be known to calculate bending moments at critical points in the safety valve installation. If a design specification exists, it should stipulate if the piping system must be designed for earthquake. If so, it should specify the magnitude of the earthquake, the plant conditions under which the earthquake is assumed to occur, and the type earthquake analysis to be used (equivalent static or dynamic). If a design specification does not exist, it is the responsibility of the designer to determine what consideration must be given to earthquake analysis. It is beyond the scope of this Appendix to provide rules for calculating moments due to earthquake. The literature contains satisfactory references for determining moments by use of static seismic coefficients and how to perform more sophisticated dynamic analyses of the piping system using inputs in such form as time histories of displacement, velocity, and acceleration or response spectra where displacement, velocity, or acceleration is presented as a function of frequency.

Two types of seismic bending moments occur. One type is due to inertia effects and the other type is due to seismic motions of pipe anchors and other attachments. As will be shown later, the moments due to inertia effects must be considered in eq. (16), para. 104.8, in the kS_h category. Moments due to seismic motions of the attachments may be combined with thermal expansion stress and considered in eq. (17), para. 104.8 in the S_A category. For this reason, it may sometimes be justified for the designer to consider the moments separately; otherwise both sets of moments would have to be included in the kS_h category.

II-3.5 Analysis for Reaction Forces Due to Valve Discharge

II-3.5.1 Open Discharge Systems

II-3.5.1.1 The moments due to valve reaction forces may be calculated by simply multiplying the force, calculated as described in para. II-2.3.1.1, times the distance from the point in the piping system being analyzed, times a suitable dynamic load factor. In no case shall the reaction moment used in para. II-4.2 at the branch connection below the valve be taken at less than the product of

$$(DLF)(F_1)(D)$$

where

D = nominal O.D. of inlet pipe

DLF = dynamic load factor (see para. II-3.5.1.3)

F_1 = force calculated per para. II-2.3.1.1

Reaction force and resultant moment effects on the header, supports, and nozzles for each valve or combination of valves blowing shall be considered.

II-3.5.1.2 Multiple Valve Arrangements. Reaction force and moment effects on the run pipe, header, supports, vessel, and connecting nozzles for each valve blowing, and when appropriate, for combinations of valves blowing should be considered. In multiple valve arrangements, each valve will open at a different time, and since all valves may not be required to open during an overpressure transient, several possible combinations of forces can exist. It may be desirable to vary the direction of discharge of several safety valves on the same header to reduce the maximum possible forces when all valves are blowing.

II-3.5.1.3 Dynamic Amplification of Reaction Forces. In a piping system acted upon by time varying loads, the internal forces and moments are generally greater than those produced under static application of the load. This amplification is often expressed as the dynamic load factor, *DLF*, and is defined as the maximum ratio of the dynamic deflection at any time to the deflection which would have resulted from the static application of the load. For structures having essentially one degree-of-freedom and a single load application, the *DLF* value will range between one and two depending on the time-history of the applied load and the natural frequency of the structure. If the run pipe is rigidly supported, the safety valve installation can be idealized as a one degree-of-freedom system and the time-history of the applied loads can often be assumed to be a single ramp function between the no-load and steady state condition. In this case, the *DLF* may be determined in the following manner:

(A) Calculate the safety valve installation period *T* using the following equation and Fig. II-3-1:

$$T = 0.1846 \sqrt{\frac{Wh^3}{EI}}$$

where

E = Young's modulus of inlet pipe, lb/in.², at design temperature

h = distance from run pipe to centerline of outlet piping, in.

I = moment of inertia of inlet pipe, in.⁴

T = safety valve installation period, sec

W = weight of safety valve, installation piping, flanges, attachments, etc., lb

(B) Calculate ratio of safety valve opening time to installation period (*t_o/T*), where *t_o* is the time the safety valve takes to go from fully closed to fully open, sec, and *T* is determined in (A) above.

(C) Enter Fig. II-3-2 with the ratio of safety valve opening time to installation period and read the *DLF*

from the ordinate. The *DLF* shall never be taken less than 1.1.

If a less conservative *DLF* is used, the *DLF* shall be determined by calculation or test.

II-3.5.1.4 Valve Cycling. Often, safety valves are full lift, pop-type valves, and are essentially full-flow devices, with no capability for flow modulation. In actual pressure transients, the steam flow required to prevent overpressure is a varying quantity, from zero to the full rated capacity of the safety valves. As a result, the valves may be required to open and close a number of times during the transient. Since each opening and closing produces a reaction force, consideration should be given to the effects of multiple valve operations on the piping system, including supports.

II-3.5.1.5 Time-History Analysis. The reaction force effects are dynamic in nature. A time-history dynamic solution, incorporating a multidegree of freedom lumped mass model solved for the transient hydraulic forces, is considered to be more accurate than the form of analysis presented in this Appendix.

II-3.5.2 Closed Discharge Systems. Closed discharge systems do not easily lend themselves to simplified analysis techniques. The discussions on pressure in para. II-2.2.2 and on forces in para. II-2.3.2 indicate that a time-history analysis of the piping system may be required to achieve realistic values of moments.

II-3.5.3 Water Seals. To reduce the problem of steam or gas leakage through the safety valve seats, the valve inlet piping may be shaped to form a water seal below each valve seat. If the valves are required to open to prevent overpressure, the water from the seal is discharged ahead of the steam as the valve disk lifts. The subsequent flow of water and steam through the discharge piping produces a significant pressure and momentum transient. Each straight run of discharge piping experiences a resulting force cycle as the water mass moves from one end of the run to the other.

For most plants that employ water seals, only the first cycle of each occurrence has a force transient based on water in the seal. The remaining cycles of each occurrence would be based on steam occupying the seal piping, and the transient forces would be reduced in magnitude.

II-4 LOADING CRITERIA AND STRESS COMPUTATION

II-4.1 Loading Criteria

All critical points in the safety valve installation shall meet the following loading criteria:

$$S_{ip} + S_{SL} \leq S_h \quad (1)$$

$$S_{ip} + S_{SL} + S_{OL} \leq kS_h \quad (2)$$

$$S_{ip} + S_{SL} + S_E \leq S_A + S_h \quad (3)$$

Fig. II-3-1 Safety Valve Installation (Open Discharge System)

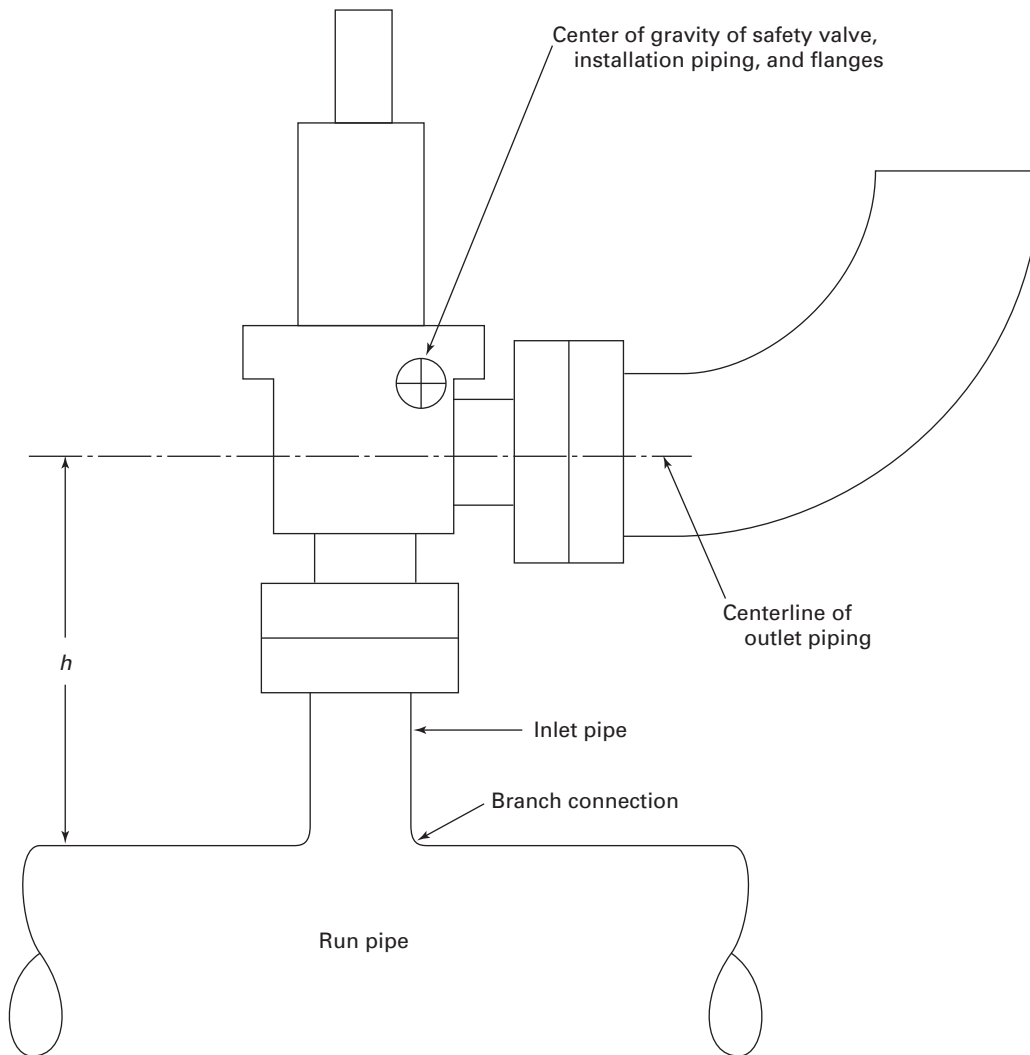
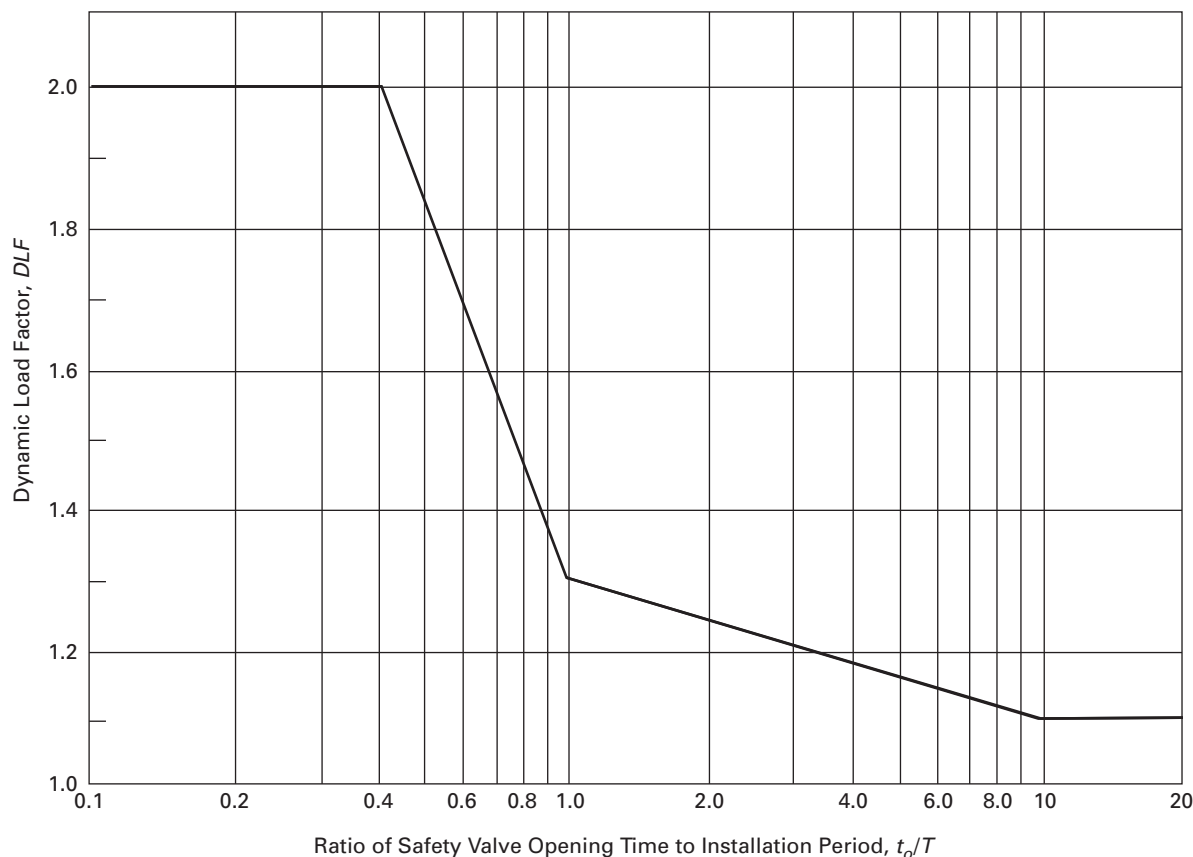

Fig. II-3-2 Dynamic Load Factors for Open Discharge System



GENERAL NOTE: This Figure is based on curves from *Introduction to Structural Dynamics*, J. M. Biggs, McGraw-Hill Book Co., 1964.

where

- S_E = bending stresses due to thermal expansion
- S_{lp} = longitudinal pressure stress
- S_{OL} = bending stresses due to occasional loads, such as earthquake, reaction from safety valve discharge, and impact loads
- S_{SL} = bending stresses due to sustained loads, such as deadweight

S_H , k , and S_A are as defined in ASME B31.1.

The three loading criteria defined above are represented by eqs. (15) and (16) in para. 104.8.

II-4.2 Stress Calculations

II-4.2.1 Pressure Stresses. The Code does not require determination of the pressure stresses that could cause failure of the pressure-containing membrane. Instead, the Code provides rules to ensure that sufficient wall thickness is provided to prevent failures due to pressure. It is not necessary to repeat these rules in this Appendix; however, some of the more important are listed below for reference.

(A) All pipe (plus other components) must satisfy the minimum required wall thickness of eq. (7) of para.

104.1.2. In addition, wall thickness must be adequate to satisfy eqs. (15) and (16) in para. 104.8. These two equations may govern determination of wall thickness in low pressure systems.

(B) No minimum wall thickness calculations are needed for components purchased to approved standards in Table 126.1.

(C) Pipe bends must meet the requirements of eq. (1) above *after* bending.

(D) Branch connections that do not meet the requirements of eq. (2) above must meet the area replacement requirements of para. 104.3.

II-4.2.2 Pressure Plus Bending Stresses. To guard against membrane failures (catastrophic), prevent fatigue (leak) failures, and to ensure shakedown, the equations in para. 104.8 must be satisfied. These equations apply to all components in the safety valve installation and will not be repeated here. However, some additional explanation of these equations in regard to the very critical points upstream of the safety valve are in the paragraphs below.

II-4.2.2.1 Additive Stresses at Branch Connection. For the purposes of eqs. (15), (16), and (17) in para. 104.8,

the section modulus and moments for application to branch connections, such as safety valve inlet pipes, are as follows:

(A) For branch connections, the Z should be the effective section modulus for the branch as defined in para. 104.8. Thus,

$$Z = Z_b = \pi r_b^2 t_s \text{ (effective section modulus)}$$

where

r_b = mean branch cross-sectional radius, in.

t_s = lesser of t_r and it_b , where

t_r = nominal thickness of run pipe

i = the branch connection stress intensification factor

t_b = nominal thickness of branch pipe

(B) Moment terms shall be defined as follows:

$$M_B = \sqrt{M_{x3}^2 + M_{y3}^2 + M_{z3}^2}$$

where M_B , M_{x3} , M_{y3} , and M_{z3} are defined in para. 104.8.

(C) Where the D_o/t_n of the branch connection differs from the D_o/t_n header or run, the larger of the two D_o/t_n values should be used in the first term of eqs. (15) and (16), where D_o and t_n are defined in paras. 104.1 and 104.8, respectively.

II-4.2.2.2 Additive Stresses in Inlet Pipe. Equations (15), (16), and (17) in para. 104.8 may be applied to the inlet pipe in the same manner as described above for the branch connection, except that the values for D_o/t_n and Z should be for the inlet pipe and the stress intensification factor used will be different. It should be noted that the values D_o , t_n , and Z should be taken from a point on the inlet pipe such that D_o/t_n will have a maximum and Z a minimum value for the inlet pipe.

II-4.2.3 Analysis of Flange. It is important that the moments from the various loading conditions described in para. II-4.2.2 do not overload the flanges on the safety valve inlet and outlet. One method of doing this is to convert the moments into an equivalent pressure that is then added to the internal pressure. The sum of these two pressures, P_{FD} , would be acceptable if either of the following criteria are met:

(A) P_{FD} does not exceed the ASME B16.5 flange rating.

(B) S_H , S_R , and S_T should be less than the yield stress at design temperature, where S_H , S_R , and S_T are as defined in 2-7 of ASME Section VIII, Division 1 with the following exceptions:

(B.1) P_{FD} should be used in the ASME Section VIII, Division 1 equations instead of the design pressure.

(B.2) S_H should include the longitudinal pressure stress at the flange hub.

II-4.2.4 Analysis of Valve. The allowable forces and moments which the piping system may place on the

safety valves must be determined from the valve manufacturer. In some cases, the valve flanges are limiting rather than the valve body.

II-5 DESIGN CONSIDERATIONS

II-5.1 General

The design of safety valve installations shall be in accordance with para. 104 except that consideration be given to the rules provided in the following subparagraphs. These rules are particularly concerned with that portion of the piping system attached to and between the safety valve and the run pipe, header, or vessel that the valve services and includes the branch connection to the run pipe, header, or vessel.

II-5.2 Geometry

II-5.2.1 Locations of Safety Valve Installations.

Safety valve installations should be located at least eight pipe diameters (based on I.D.) downstream from any bend in a high velocity steam line to help prevent sonic vibrations. This distance should be increased if the direction of the change of the steam flow is from vertical upwards to horizontal in such a manner as to increase density of the flow in the area directly beneath the station nozzles. Similarly, safety valve installation should not be located closer than eight pipe diameters (based on I.D.) either upstream or downstream from fittings.

II-5.2.2 Spacing of Safety Valve Installation. Spacing of safety valve installations must meet the requirements in Note (10)(c), Mandatory Appendix D, Table D-1.

II-5.3 Types of Valves and Installations

II-5.3.1 Installations With Single Outlet Valves.

Locate unsupported valves as close to the run pipe or header as is physically possible to minimize reaction moment effects.

Orientation of valve outlet should preferably be parallel to the longitudinal axis of the run pipe or header.

Angular discharge elbows oriented to minimize the reaction force moment shall have a straight pipe of at least one pipe diameter provided on the end of the elbow to ensure that the reaction force is developed at the desired angle. Cut the discharge pipe square with the centerline. Fabrication tolerances, realistic field erection tolerances, and reaction force angle tolerances must be considered when evaluating the magnitude of the reaction moment.

The length of unsupported discharge piping between the valve outlet and the first outlet elbow [Fig. II-1.2(A), distance l] should be as short as practical to minimize reaction moment effects.

II-5.3.2 Installations With Double Outlet Valves.

Double outlet valves with symmetrical tail-pipes and vent stacks will eliminate the bending moment in the

nozzle and the run pipe or header providing there is equal and steady flow from each outlet. If equal flow cannot be guaranteed, the bending moment due to the unbalanced flow must be considered. Thrust loads must also be considered.

II-5.3.3 Multiple Installations. The effects of the discharge of multiple safety valves on the same header shall be such as to tend to balance one another for all modes of operation.

II-5.4 Installation Branch Connections

Standard branch connections shall as a minimum meet the requirements of para. 104.3. It should be noted that branch connections on headers frequently do not have sufficient reinforcement when used as a connection for a safety valve. It may be necessary to provide additional reinforcing (weld deposit buildup) or special headers that will satisfactorily withstand the reaction moments applied.

Material used for the branch connection and its reinforcement shall be the same or of higher strength than that of the run pipe or header.

It is strongly recommended that branch connections intersect the run pipe or header normal to the surface of the run pipe or header at $\alpha = 90$ deg, where α is defined as the angle between the longitudinal axis of the branch connection and the normal surface of the run pipe or header. Branch connections that intersect the run pipe or headers at angles,

$$90 \text{ deg} > \alpha \geq 45 \text{ deg}$$

should be avoided. Branch connections should not in any case intersect the run pipe or header at angles,

$$\alpha < 45 \text{ deg}$$

II-5.5 Water in Installation Piping

II-5.5.1 Drainage of Discharge Piping. Drains shall be provided so that condensed leakage, rain, or other water sources will not collect on the discharge side of the valve and adversely affect the reaction force. Safety valves are generally provided with drain plugs that can be used for a drain connection. Discharge piping shall be sloped and provided with adequate drains if low points are unavoidable in the layout.

II-5.5.2 Water Seals. Where water seals are used ahead of the safety valve, the total water volume in the seals shall be minimized. To minimize forces due to slug flow or water seal excursion, the number of changes of direction and the lengths of straight runs of installation piping shall be limited. The use of short radius elbows is also discouraged; the pressure differential across the cross section is a function of the elbow radius.

II-5.6 Discharge Stacks

If telescopic or uncoupled discharge stacks, or equivalent arrangements, are used then care should be taken to ensure that forces on the stack are not transmitted to the valve discharge elbow. Stack clearances shall be checked for interference from thermal expansion, earthquake displacements, etc. Discharge stacks shall be supported adequately for the forces resulting from valve discharge so that the stack is not deflected, allowing steam to escape in the vicinity of the valve. In addition, the deflection of the safety valve discharge nozzle (elbow) and the associated piping system when subjected to the reaction force of the blowing valve shall be calculated. This deflection shall be considered in the design of the discharge stacks slip-joint to ensure that the discharge nozzle remains in the stack, preventing steam from escaping in the vicinity of the valve.

To prevent blowback of discharging steam from inlet end of vent stack, consider the use of an antiblowback device that still permits thermal movements of header.

II-5.7 Support Design

Supports provided for safety valves and the associated piping require analysis to determine their role in restraint as well as support. These analyses shall consider at least the following effects:

(A) differential thermal expansion of the associated piping, headers, and vessels.

(B) dynamic response characteristics of the support in relation to the equipment being supported and the structure to which it is attached, during seismic events and valve operation. Maximum relative motions of various portions of the building and structures to which supports are attached resulting from seismic excitation must be considered in selecting, locating, and analyzing support systems.

(C) capability of the support to provide or not provide torsional rigidity, per the support design requirements.

II-5.7.1 Pipe Supports. Where necessary, it is recommended that the support near the valve discharge be connected to the run pipe, header, or vessel rather than to adjacent structures in order to minimize differential thermal expansion and seismic interactions.

Each straight leg of discharge piping should have a support to take the force along that leg. If the support is not on the leg itself, it should be as near as possible on an adjacent leg.

When a large portion of the system lies in a plane, the piping, if possible, should be supported normal to that plane even though static calculations do not identify a direct force requiring restraint in that direction. Dynamic analyses of these systems have shown that out-of-plane motions can occur.

II-5.7.2 Snubbers. Snubbers are often used to provide a support or a stop against a rapidly applied load,

such as the reaction force of a blowing valve or the pressure-momentum transient in a closed piping system. Since snubbers generally displace a small distance before becoming rigid, the displacement must be considered in the analysis. In addition, if the load is applied to the snubber for a relatively long time, the snubber performance characteristics shall be reviewed to ensure that the snubber will not permit motion during the time period of interest, or the additional displacement must be considered in the analysis. The snubber performance shall also be reviewed for response to repetitive load applications caused by the safety valve cycling open and closed several times during a pressure transient.

II-5.8 Silencer Installation

Silencers are occasionally installed on safety valve discharges to dissipate the noise generated by the sonic velocity attained by the fluid flowing through the valve.

Silencers must be properly sized to avoid excessive backpressure on the safety valve causing improper valve action or reducing relieving capacity.

Safety valve discharge piping, silencers, and vent stacks shall be properly supported to avoid excessive loading on the valve discharge flange.

II-6 SAMPLE DESIGNS

Examples of various safety valve installations that a designer may encounter in practice are presented in Fig. II-1.2(A) and Fig. II-6-1.

II-7 SAMPLE PROBLEM (SEE FIG. II-7-1 AND FIG. II-7-2)

II-7.1 Procedure

- (A) Determine pressure and velocity at discharge elbow exit.
- (B) Calculate maximum operating pressure for discharge exit.
- (C) Calculate reaction force at discharge elbow exit.
- (D) Calculate bending moments of Points (1) and (2) from reaction force and seismic motion.
- (E) Determine stress intensification factors at Points (1) and (2).
- (F) Calculate predicted stresses at Points (1) and (2) and compare with allowable stress.
- (G) Calculate maximum operating pressure for vent pipe.
- (H) Check for blowback.
- (I) Calculate forces and moments on vent pipe.

II-7.1.1 Pressure and Velocity at Discharge Elbow Exit (Para. II-2.2.1)

$$P_1 = \frac{W(b-1)}{A_1 b} \sqrt{\frac{2(h_o - a)J}{g_c(2b-1)}}$$

$$V_1 = \sqrt{\frac{2g_c J(h_o - a)}{(2b - 1)}}$$

where

- $A_1 = 50.03 \text{ in.}^2$
- $a = 823 \text{ Btu/lbm}$ for $15 \leq P_1 \leq 1,000 \text{ psia}$ and $h_o \leq 1,600 \text{ Btu/lbm}$
- $b = 4.33$ for $15 \leq P_1 \leq 1,000 \text{ psia}$ and $h_o \leq 1,600 \text{ Btu/lbm}$
- $g_c = 32.2 \text{ lbf-ft/lbf-sec}^2$
- $h_o = \text{stagnation enthalpy for steam at } 925 \text{ psia, } 1,000^\circ\text{F}$
 $= 1,507.3 \text{ Btu/lbm}$
- $J = 778 \text{ ft-lbf/Btu}$
- $P_1 = 118 \text{ psia}$
- $V_1 = 2,116 \text{ ft/sec}$
- $W = \text{flow rate}$
 $= 116.38 \text{ lbfm/sec}$

II-7.1.2 Discharge Elbow Maximum Operating Pressure. For 8 in. Class 150 ASME weld neck flange,

$$\frac{L}{D} = \frac{4 \text{ in.}}{7.981 \text{ in.}} = 0.5$$

For 8 in. SCH 40 short radius elbow,

$$\frac{L}{D} = 30$$

For 12 in. of 8 in. SCH 40 pipe,

$$\frac{L}{D} = \frac{12 \text{ in.}}{7.981 \text{ in.}} = 1.5$$

$$\Sigma \left(\frac{L}{D}\right) = \left(\frac{L_{\text{max}}}{D}\right) = 0.5 + 30 + 1.5 = 32.0$$

$$f = 0.013$$

$$k = 1.3$$

$$f \left(\frac{L_{\text{max}}}{D}\right) = 0.416$$

From Chart II-1, $P/P^* = 1.647$.

$$P_{1a} = P_1 (P/P^*) = 194 \text{ psia}$$

II-7.1.3 Reaction Force at Discharge Elbow Exit.

Reaction force,

$$F_1 = \frac{WV_1}{g_c} + (P_1 - P_a) A_1$$

where

- $W = 116.38 \text{ lbfm/sec}$
- $V_1 = 2,116 \text{ ft/sec}$
- $g_c = 32.2 \text{ lbfm-ft/lbf-sec}^2$
- $P_1 = 118 \text{ psia}$
- $P_a = 15 \text{ psia}$
- $A_1 = 50.03 \text{ in.}^2$

Fig. II-6-1 Examples of Safety Valve Installations

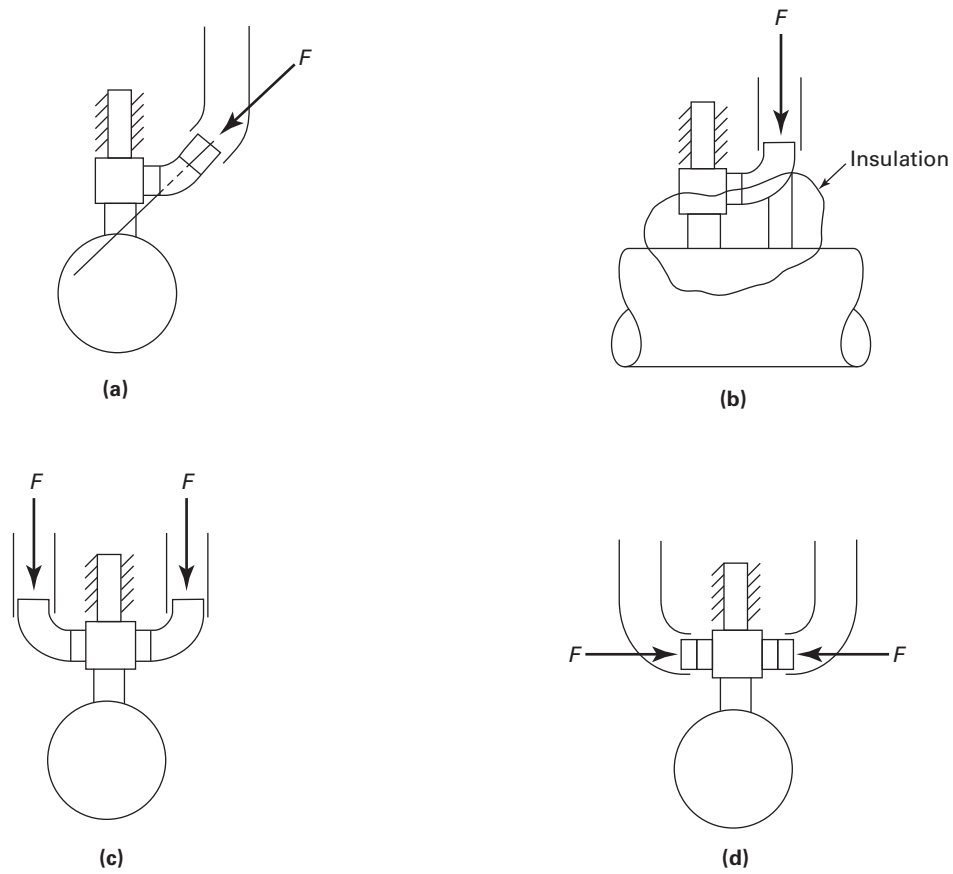

F = reaction force

Fig. II-7-1 Sample Problem Figure 1

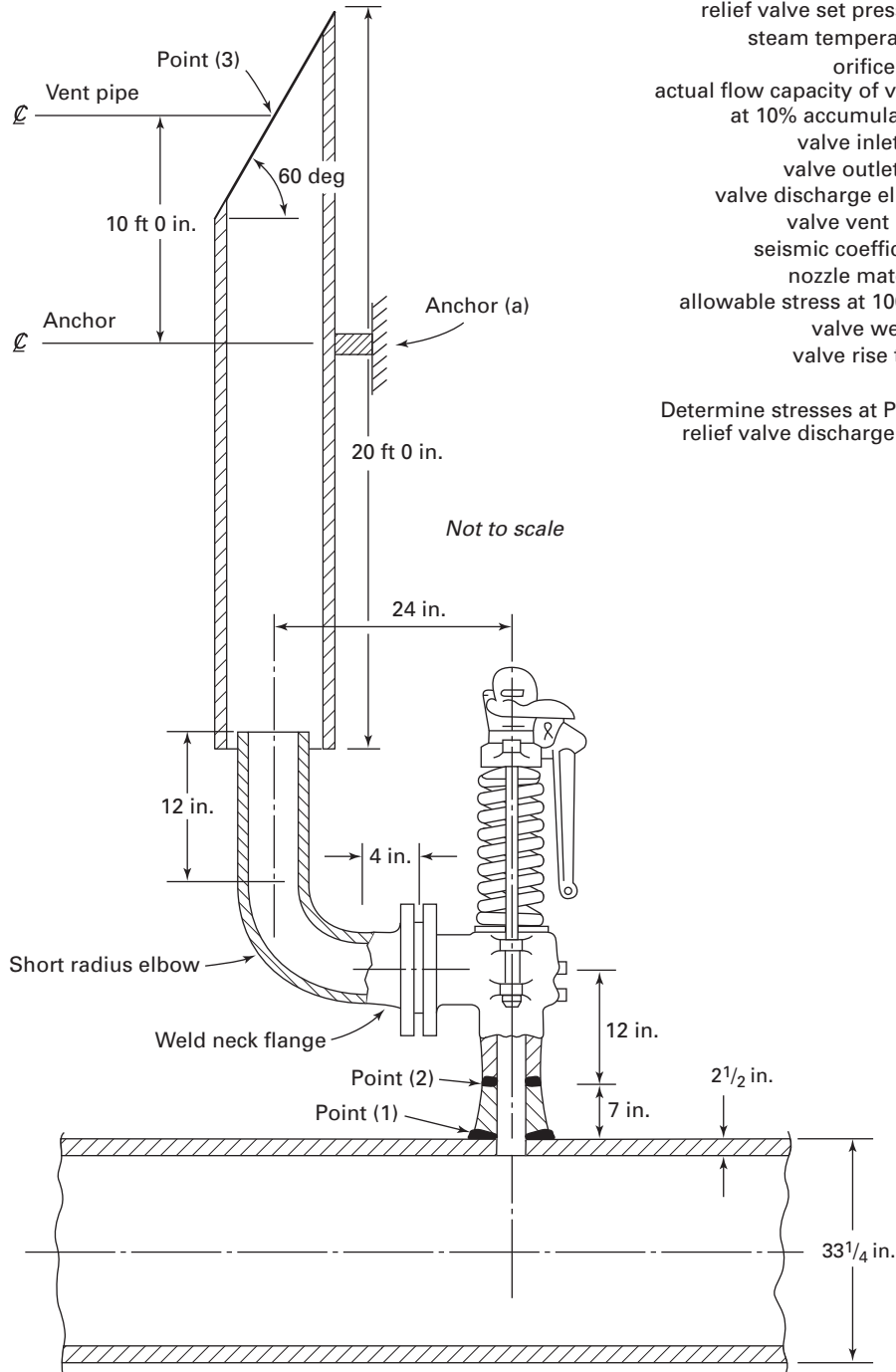

- relief valve set pressure = 910 psig
- steam temperature = 1,000°F
- orifice size = 11.05 in.² (Q orifice)
- actual flow capacity of valve
- at 10% accumulation = 418,950 lbm/hr
- valve inlet I.D. = 6 in.
- valve outlet I.D. = 8 in.
- valve discharge elbow = 8 in. SCH 40
- valve vent pipe = 12 in. SCH 30
- seismic coefficient = 1.5g
- nozzle material = ASTM A335 P22 2¹/₄Cr-1Mo
- allowable stress at 1000°F = 7,800 psi
- valve weight = 800 lb
- valve rise time = 0.040 sec

Determine stresses at Points (1) and (2) due to seismic and relief valve discharge loads only.

Fig. II-7-2 Sample Problem Figure 2

$$i = 1.5 \left(\frac{R_m}{T_r} \right)^{2/3} \left(\frac{r'_m}{R_m} \right)^{1/2} \left(\frac{T'_b}{T_r} \right) \left(\frac{r'_m}{r_p} \right)$$

R_m , T_r , r'_m , T'_b , and r_p are shown in sketch below:

$$i_{(1)} = 1.5 \left(\frac{15.375}{2.5} \right)^{2/3} \left(\frac{4.25}{15.375} \right)^{1/2} \left(\frac{2.5}{2.5} \right) \left(\frac{4.25}{5.5} \right)$$

$$i_{(1)} = 2.05$$

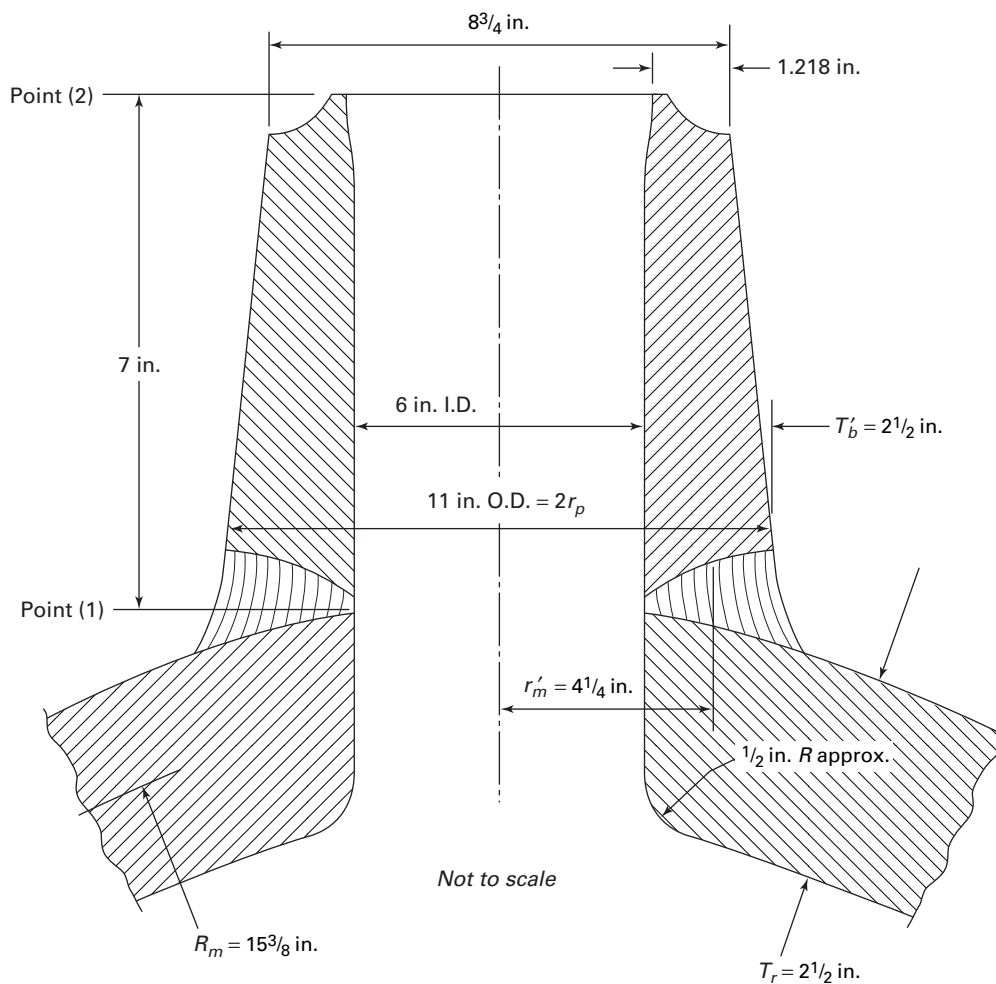

$$\begin{aligned}(P_1 - P_a) &= 118 - 15 = 103 \text{ psig} \\ WV_1/g_c &= 7,648 \text{ lbf} \\ (P_1 - P_a) A_1 &= 5,153 \text{ lbf} \\ F_1 &= 12,801 \text{ lbf}\end{aligned}$$

II-7.1.4 Bending Moments at Points (1) and (2)

(A) *Bending Moment at Points (1) and (2) Due to Reaction at Point (1)*

$$\begin{aligned}M_{1(1)} &= M_{1(2)} \\ &= F_1 \times L \times DLF \\ L &= \text{moment arm} \\ &= 24 \text{ in.} \\ DLF &= \text{dynamic load factor}\end{aligned}$$

To determine *DLF*, first determine the safety valve installation period *T*:

$$T = 0.1846 \sqrt{\frac{Wh^3}{EI}}$$

where

- E* = Young's modulus of inlet pipe at design temperature
= 23×10^6 psi
- h* = distance from run pipe to centerline of outlet piping
= 19 in.
- I* = moment of inertia of inlet pipe
= $\frac{\pi}{64} (D_o^4 - D_i^4)$
Use average O.D. and I.D. to determine *I*. *D_o* = 9.875 in. avg.; *D_i* = 6 in. avg.
= 403.2 in.⁴
- T* = 0.00449 sec
- W* = weight of valve
= 800 lb

For a valve rise time of 0.040 sec = *t_o*, the ratio *t_o*/*T* is 8.9. From Fig. II-3-2, *DLF* = 1.11.

Using *F₁* = 12,801 lbf, *L* = 24 in., and *DLF* = 1.11,

$$M_{1(1)} = M_{1(2)} = 341,018 \text{ in.-lb}$$

(B) *Bending Moments at Points (1) and (2) Due to Seismic Loading*

Seismic force, *F_S* = mass × acceleration

$$\begin{aligned}&= \left[\frac{800 \text{ lbm}}{32.2 \text{ lbm-ft/lbf-sec}^2} \right] \\ &\times 1.5(32.2 \text{ ft/sec}^2) \\ &= 1,200 \text{ lbf}\end{aligned}$$

Moment arm for Point (1) = 19 in.

$$M_{S(1)} = 1,200 \text{ lbf (19 in.)} = 22,800 \text{ in.-lb}$$

Moment arm for Point (2) = 12 in.

$$M_{S(2)} = 1,200 \text{ lbf (12 in.)} = 14,400 \text{ in.-lb}$$

(C) *Combined Bending Moments at Points (1) and (2)*

$$M_{(1)} = M_{1(1)} + M_{S(1)} = 363,819 \text{ in.-lb}$$

$$M_{(2)} = M_{1(2)} + M_{S(2)} = 355,419 \text{ in.-lb}$$

II-7.1.5 Stress Intensification Factors at Points (1) and (2)

(A) *At Point (1), Branch Connection*

$$i_{(1)} = 2.05$$

(B) *Stress Intensification Factors at Point (2), Butt Weld*

$$i_{(2)} = 1.0$$

II-7.1.6 Predicted Stresses at Points (1) and (2)

(A) *Predicted Stresses at Point (1), Branch Connection*

$$\text{Predicted stress} = \frac{PD_o}{4t_n}$$

$$\frac{D_o}{t_n} \text{ for run pipe} = \frac{33.25 \text{ in.}}{2.5 \text{ in.}} = 13.3$$

$$\frac{D_o}{t_n} \text{ for branch pipe} = \frac{11 \text{ in.}}{2.5 \text{ in.}} = 4.4$$

Use larger value with *P* = 910 psig.

$$\text{Pressure stress}_{(1)} = 3,030 \text{ psi}$$

$$\text{Flexure stress}_{(1)} = \frac{0.75i M_{(1)}}{Z_{(1)}}$$

$$Z_{(1)} = \pi r_b^2 t_s$$

$$t_s = \text{lesser of } t_r \text{ or } (i) t_b$$

$$t_R = 2.5 \text{ in.}; (i) t_b = (2.05) 2.5 \text{ in.}$$

$$t_s = 2.5 \text{ in.}$$

$$r_b = 4.25 \text{ in.}$$

$$Z_{(1)} = 142 \text{ in.}^3$$

$$i_{(1)} = 2.05; M_{(1)} = 363,819 \text{ in.-lb}$$

$$\begin{aligned}\text{Flexure stress}_{(1)} &= 3,939 \text{ psi} \\ \text{Combined stress}_{(1)} &= \text{pressure stress}_{(1)} \\ &\quad + \text{flexure stress}_{(1)} \\ &= 6,969 \text{ psi}\end{aligned}$$

(B) *Predicted Stresses at Point (2), Butt Weld*

$$\text{Pressure stress} = \frac{PD_o}{4t_n}$$

$$P = 910 \text{ psig}$$

$$D_o = 8.75 \text{ in.}$$

$$t_n = 1.218 \text{ in.}$$

$$\text{Pressure stress}_{(2)} = 1,635 \text{ psi}$$

$$\text{Flexure stress}_{(2)} = \frac{0.75 i M_{(2)}}{Z_{(2)}}$$

$$Z_{(2)} = \frac{\pi}{32} \frac{D_o^4 - D_i^4}{D_o}$$

$$D_o = 8.75 \text{ in.}$$

$$D_i = 6 \text{ in.}$$

$$Z_{(2)} = 51.1 \text{ in.}^3$$

$$i_{(2)} = 1.0$$

$$M_{(2)} = 355,419 \text{ in.-lb}$$

$$\text{Flexure stress}_{(2)} = 6,955 \text{ psi}$$

(Note that $0.75i$ is set equal to 1.0 whenever $0.75i$ is less than 1.0, as in this case.)

$$\begin{aligned} \text{Combined stress}_{(2)} &= \text{pressure stress}_{(2)} \\ &\quad + \text{flexure stress}_{(2)} \\ &= 8,590 \text{ psi} \end{aligned}$$

(C) Comparison of Predicted Stress With Allowable Stress.
Allowable stress of nozzle material at 1,000°F is

$$S_h = 7,800 \text{ psi}$$

$$k = 1.2$$

$$kS_h = 9,360 \text{ psi}$$

$$\text{Combined stress}_{(1)} = 6,969 \text{ psi}$$

$$\text{Combined stress}_{(2)} = 8,590 \text{ psi}$$

II-7.1.7 Calculate the Maximum Operating Pressure for Vent Pipe

$$P_3 = P_1 \left(\frac{A_1}{A_3} \right) = 118 \text{ psia} \left(\frac{50.03 \text{ in.}^2}{114.80 \text{ in.}^2} \right)$$

$$= 51.4 \text{ psia}$$

L/D for 20 ft 0 in. of 12 in. SCH 30 pipe = 19.85.

$$\Sigma(L/D) = \left(\frac{L_{\max}}{D} \right) = 19.85$$

$$f = 0.013$$

$$k = 1.3$$

$$f \left(\frac{L_{\max}}{D} \right) = 0.258$$

From Chart II-1, $P/P^* = 1.506$.

$$P_2 = P_3 (P/P^*) = 77.4 \text{ psia}$$

II-7.1.8 Check for Blowback From Vent Pipe. Calculate the velocity V_2 that exists at the inlet to the vent pipe (para. II-2.2.1.4).

$$f \left(\frac{L_{\max}}{D} \right) = 0.258 \text{ from Step (7)}$$

$$V_3 = V_1 = 2,116 \text{ ft/sec}$$

From Chart II-1, $V/V^* = 0.7120$.

$$V_2 = V_3 (V/V^*) = 1,507 \text{ ft/sec}$$

Check the inequality from para. II-2.3.1.2.

$$\frac{W(V_1 - V_2)}{g_c} > (P_2 - P_a) A_2 - (P_1 - P_a) A_1$$

$$\frac{116.38(2,116 - 1,507)}{32.2} > (77.4 - 14.7)(114.8) - (118 - 14.7)(50.03)$$

$$2,201 > 2,030$$

The inequality has been satisfied but the designer may require a design margin that would make 14 in. SCH 30 more acceptable. If a larger vent pipe is chosen, then the vent pipe analysis would have to be repeated for the 14 in. SCH 30 pipe.

II-7.1.9 Calculate Forces and Moments on Vent Pipe Anchor

$$F_2 = \frac{WV_2}{g_c} + (P_2 - P_a) A_2$$

$$= \frac{(116.38)(1,507)}{32.2}$$

$$+ (77.4 - 14.7)(114.8)$$

$$= 5,447 + 7,198.0 = 12,645 \text{ lbf}$$

$$F_3 = \frac{(116.38)(2,116)}{32.2}$$

$$+ (51.4 - 14.7)(114.8)$$

$$= 7,648 + 4,213 = 11,861 \text{ lbf}$$

Assume a 30 deg jet deflection angle for vent pipe outlet.
Vertical component of F_3

$$F_{3V} = F_3 \cos 30 \text{ deg} = 10,272 \text{ lbf}$$

Horizontal component of F_3

$$F_{3H} = F_3 \sin 30 \text{ deg} = 5,931 \text{ lbf}$$

Net imbalance on the vent pipe in the vertical direction is

$$F_2 - F_{3V} = 2,373 \text{ lbf}$$

Moment on vent pipe anchor

$$\begin{aligned} \Sigma M &= (F_2 - F_{3V}) \frac{D_o}{2} \\ &+ F_{3H} \times [\text{distance from (a) to Point (3)}] \\ &= (2,373) \left(\frac{1.06}{2} \right) + (5,931)(10.0) \\ &= 60,568 \text{ ft-lb} \end{aligned}$$

The vent pipe anchor would then be designed for the loads shown in Fig. II-7-3 for safety valve operation.

II-7.1.10 Conclusion. Branch connection stresses at Points (1) and (2) due to seismic and relief valve discharge are within $1.2 S_h$. Blowback will not occur with the 12 in. standard weight vent pipe. The vent pipe anchor loads have been identified.

Fig. II-7-3 Sample Problem Figure 3

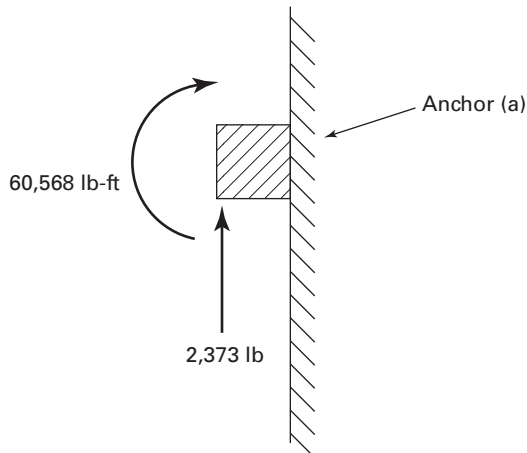

NONMANDATORY APPENDIX IV CORROSION CONTROL FOR ASME B31.1 POWER PIPING SYSTEMS

FOREWORD

Present Code rules apply to the design, materials, fabrication, erection, tests, and inspection of new piping systems normally termed “new construction.”

This Appendix contains guidelines that are applicable to existing operating piping systems contained in the scope of ASME B31.1, as well as “new construction.”

Minimum requirements for corrosion control of power piping systems are outlined herein. It is recognized that many sound, although perhaps diverse, corrosion control programs exist. The philosophy used has been to establish minimum requirements. Users are encouraged to augment these guidelines to suit their particular needs and to offer constructive criticism to the Committee on this Appendix.

IV-1 GENERAL

External and internal corrosion should be prevented or controlled consistent with design requirements and the environment in which the system is located.

IV-1.1 Recommended Guidance

Application of corrosion control requires a significant amount of competent judgment. NACE¹ RP-01-69, Recommended Practice-Control of External Corrosion on Underground or Submerged Metallic Piping Systems, and RP-01-75, Recommended Practice-Control of Internal Corrosion in Steam Pipelines and Piping Systems, provide a guide for establishing the minimum requirements for control of corrosion of underground or submerged metallic piping systems. In addition, ASME B31G, Manual for Determining the Remaining Strength of Corroded Pipelines [3] may provide additional guidance.

IV-1.2 Protection of All Piping Systems

The following minimum requirements and procedures should be provided for protection of all piping systems containing hazardous liquids or gases and other piping as specified by the owner against internal, external, and atmospheric corrosion.

¹ NACE: National Association of Corrosion Engineers (NACE International), 15835 Park Ten Place, Houston, TX 77084

IV-2 EXTERNAL CORROSION CONTROL FOR BURIED OR SUBMERGED PIPELINES

IV-2.1 General

IV-2.1.1 Means to prevent or mitigate external corrosion of buried or submerged piping systems should be considered in the initial design, unless it can be demonstrated by tests, investigations, or experience in the area of installation that a detrimental corrosive environment does not exist.

IV-2.1.2 A means for control of external corrosion of buried or submerged pipe and components may be accomplished through application of an effective protective coating or wrapping. This method of corrosion control can be supplemented with cathodic protection such as sacrificial anodes, rectifier-ground bed units, and suitable drainage bonds in stray current areas. Materials should be selected with due regard to the type of supplemental corrosion protection employed.

IV-2.2 Protective Coating

IV-2.2.1 Protective coatings applied for the purpose of external corrosion should

- (A) be applied on a properly prepared surface
- (B) mitigate corrosion
- (C) have sufficient adhesion to the metal surface and be free of voids so as to effectively resist underfilm migration of moisture
- (D) be sufficiently ductile to resist cracking
- (E) have sufficient strength to resist damage due to handling and soil stress
- (F) be impact resistant

IV-2.2.2 Coatings should have low moisture absorption characteristics and provide high electrical resistance. Properly compounded concrete coatings may be used.

IV-2.2.3 Pipe coatings should be inspected visually with a holiday detector and thickness gage prior to backfilling the excavation. Any bare spots, thin areas, holidays, or other damage to the coating should be repaired and reexamined prior to backfilling.

IV-2.2.4 Precautions should be taken to minimize pipe coating damage during installation if coated pipe is installed by boring, driving, or similar method.

IV-2.2.5 Pipe coatings should be protected from damage resulting from adverse ditch conditions or damage from supporting blocks. Only fine grain backfill is permitted in contact with the coating. This fine grain layer should be continuous and of sufficient thickness to prevent coating damage from larger articles in the backfill.

IV-2.2.6 The backfilling operation should be carefully controlled to prevent damage to pipe coatings.

IV-2.3 Cathodic Protection System

IV-2.3.1 Unless it can be demonstrated by investigation, tests, or experience that cathodic protection is not needed, a cathodic protection system should be installed for all new buried carbon steel, alloy, ductile iron, cast iron, aluminum, or other metallic piping.

IV-2.3.2 All cathodic protection systems should comply with one or more of the criteria contained in Section 6 of the latest issue of the NACE Standard RP-01-69.

IV-2.3.3 Cathodic protection current should be controlled so as to prevent damage to the protective coating, pipe, or components.

IV-2.4 Electrical Isolation

IV-2.4.1 Buried or submerged coated and uncoated piping systems should be electrically isolated at all interconnections with neighboring systems except where arrangements are made for mutual cathodic protection or where underground metallic structures are electrically interconnected and cathodically protected as a unit. Electrical isolation of dissimilar metals, i.e., steel pipe connected to aluminum tanks, should be provided.

IV-2.4.2 Grounding of all piping systems, where required, should be in accordance with IEEE² Standard 142 or acceptable alternate standards.

IV-2.4.3 The electrical continuity of all buried or submerged metallic piping systems is recommended for proper station grounding, and to facilitate the installation of cathodic protection. Continuity across all mechanical joints should be achieved by electrical bonding.

IV-2.4.4 Where piping systems are located near electrical transmission tower footings, ground cables, ground rods, or in other areas where fault currents or unusual risk of lightning may be anticipated, piping should be provided with protection against damage that may result from fault currents or lightning. Protective measures should also be taken at insulating devices where used.

IV-2.4.5 If a pipe culvert or sleeve is used, the enclosed pipe should be independently supported outside each end of the sleeve and electrically insulated throughout the length of the section.

IV-2.5 Electrical Interference

IV-2.5.1 The possibility of external corrosion induced by stray electrical currents in the earth is recognized. These stray currents are generated by sources independent of the piping system, and are more predominant in highly industrialized areas, mining regions, and locales containing high voltage, direct current, electrical power ground beds. Neighbor company pipeline cathodic protection systems are also a common source of stray earth currents.

IV-2.5.2 The protection of the piping system against stray current induced corrosion should be provided by metallic bonds, increased electrical cathodic protection, supplemental protective coatings, or insulating flanges.

IV-2.5.3 Each cathodic protection system provided for the plant piping should be designed and installed so as to minimize any adverse effects on adjacent underground metallic structures.

IV-3 INTERNAL CORROSION CONTROL

IV-3.1 General

Internal corrosion might occur during operation. A liquid or gas that will corrode the internal surfaces of piping should not be transported unless its corrosive effects have been investigated. The piping material and any lining should be selected to be compatible with the flowing fluid to minimize corrosion, in accordance with NACE Standard RP-01-75.

IV-3.2 Inhibitors

If inhibitors are used to control internal corrosion, sufficient coupon samples or other types of monitoring techniques should be utilized to determine adequately the effectiveness of the inhibitors.

IV-3.3 Linings

If linings are used to prevent corrosion, they should meet the quality specifications established by the design engineer. They should be inspected in accordance with industry recommended practices. All base material and weld metal surfaces should be covered with the lining to at least the thickness specified by the designer.

IV-3.4 Precautions at Hydrotesting

Equipment fabricated from austenitic (300 series) and ferritic (400 series) stainless steels and requiring hydrostatic testing should be tested with deionized water,

² IEEE: Institute of Electrical and Electronics Engineers, 445 Hoes Lane, Piscataway, NJ 08854

high purity steam condensate, or potable water, in decreasing order of preference.

NOTE: Potable water in this context follows U.S. practice, with 250 parts per million maximum chloride content, sanitized with chlorine or ozone.

After testing is completed, equipment should be thoroughly drained with all high point vents open during draining, and dried by air blowing, swabbing, or other appropriate means. If immediate draining and drying are not possible, hydrotest water should be circulated in the piping for at least one hour daily to reduce the possibility of pitting and microbiologically influenced corrosion.

IV-4 EXTERNAL CORROSION CONTROL FOR PIPING EXPOSED TO THE ATMOSPHERE

Piping that is exposed to the atmosphere should be protected against external corrosion by use of corrosion resistant materials or by application of protective coatings or paints.

IV-5 MONITORING OF PIPE WALL THINNING DUE TO EROSION/CORROSION

IV-5.1 Definition

Erosion/corrosion (E/C) is a flow-accelerated corrosion process that leads to loss of wall thickness in carbon or low alloy steel pipe exposed to water or wet steam. The parameters that affect the rate of metal loss include water or steam temperature, pH, oxygen content of the fluid, steam quality, flow velocity and piping layout, and the piping chromium, copper, and molybdenum content. This paragraph, IV-5, does not apply to other wall thinning mechanisms, such as general corrosion, microbiologically influenced corrosion, or cavitation.

(16) IV-5.2 Systems and Components Susceptible to Erosion/Corrosion

Erosion/corrosion has caused piping failures or severe wall thinning in the following systems:

- (A) feedwater, auxiliary feedwater
- (B) feedwater recirculation
- (C) condensate recirculation
- (D) blowdown
- (E) turbine crossaround/crossover
- (F) extraction steam
- (G) moisture separator reheater
- (H) feedwater heater drains, drips, and vents

Piping damage due to E/C is not limited to these systems and may occur in any system of carbon steel or low alloy piping that is exposed to water or wet steam and operates at a temperature greater than 200°F (93°C). System parameters and their effect on E/C rates are shown in Table IV-5.2.

Table IV-5.2 Erosion/Corrosion Rates

(16)

Parameter	E/C Rate Increases if Parameter Is
Fluid velocity	Higher [over 10 fps (3 m/s) for water, over 150 fps (45 m/s) for steam]
Fluid pH level	Less than 9.2
Fluid oxygen content	Less than 30 ppb
Fluid temperature	200°F–450°F (93°C–232°C) (water) 200°F–500°F (93°C–260°C) (wet steam)
Steam quality	Less than 100%
Component geometry	Such as to create more turbulence
Component alloy content of chromium, copper, and molybdenum	Lower

Typical piping components known to experience wall thinning due to E/C include elbows, tees, reducers, and closely coupled fittings. Piping downstream and upstream of these fittings and downstream of orifices and control valves is also susceptible.

IV-5.3 Methods of Detection

(16)

Detection of wall thinning due to E/C may be accomplished by a number of NDE techniques including visual, radiographic, ultrasonic, and other measurement methods. However, the most widely used method for detection of wall thinning caused by E/C is ultrasonic thickness examination. Current industry practice supports use of a repeatable grid pattern with identifiable reference points at grid intersections. Grid sizes should not be greater than $2\sqrt{rt_n}$, where r is the outside radius and t_n is the nominal wall thickness of the piping item, except that grid sizes need not be smaller than 1 in. (25 mm) and should not be larger than 6 in. (150 mm). Thickness readings should be recorded at the grid intersection points and the pipe between the grid points scanned for detection of local thinning. If unacceptable thinning is detected, additional readings should be made and recorded with a refined or expanded grid. If thinning is detected within the boundaries of a component grid, a refined grid should be defined within the component to further define the region of wear and provide locations for documentation of measurements. If unacceptable thinning is found at the boundary of a grid, the grid should be expanded in the direction of thinning until thickness readings become acceptable.

IV-5.4 Acceptance Standards

The Code-required wall thickness, t_m , of each component inspected shall be determined in accordance with para. 104 of the Code. The required wall thickness should include consideration of the minimum wall thickness

required to satisfy all of the stress requirements of para. 104.

A calculation of predicted wall thickness, t_p , at the next examination should be performed for all components with measured wall thickness less than 87.5% of nominal wall thickness t_n .

(A) All components with t_p at the next examination of less than t_m or 70% t_n , whichever is greater, should be identified. Additional examinations during the current inspection should be performed for

(A.1) equivalent piping items in other trains when the system containing the subject piping item consists of more than one train

(A.2) additional components in the same system/pipeline that have been determined to be susceptible to E/C

When (1) and (2) above reveal additional components that meet the criteria of (a)(1) above, this process should be repeated until no additional components meet the criteria.

(B) All components with predicted wall thickness at the next examination of less than or equal to the greater of t_m or $0.3t_n$ shall be repaired, replaced, or evaluated for acceptability for continued service. An acceptable evaluation procedure has been provided in [2] and [3] of para. IV-5.6.

IV-5.5 Repair/Replacement Procedures

Repair or replacement of piping components should be performed in accordance with Nonmandatory Appendix V. Erosion rates for chrome-molybdenum alloys are significantly lower than carbon steels and virtually nonexistent for stainless steels. When replacement is chosen, consideration of the increased resistance of alloy steels to E/C should be included in the selection of the replacement component material. The use of backing rings, which can create areas of local turbulence that will promote E/C damage, should be avoided.

IV-5.6 References

- [1] ASME Code Case N-480, Approved May 1, 1990.
- [2] EPRI Report NP-5911M, "Acceptance Criteria for Structural Evaluation of Erosion/Corrosion Thinning in Carbon Steel Piping," July 1988.
- [3] ASME B31G, Manual for Determining the Remaining Strength of Corroded Pipelines.
- [4] NUREG-1344, "Erosion/Corrosion-Induced Pipe Wall Thinning in U. S. Nuclear Power Plants," April 1989.
- [5] EPRI Report NP-3944, "Erosion/Corrosion in Nuclear Plant Steam Piping: Causes and Inspection Program Guidelines," April 1985.

NONMANDATORY APPENDIX V

RECOMMENDED PRACTICE FOR OPERATION, MAINTENANCE, AND MODIFICATION OF POWER PIPING SYSTEMS

FOREWORD

The B31.1 Power Piping Code prescribes minimum requirements for the construction of power and auxiliary service piping within the scope of para. 100.1. The Code, however, does not provide rules or other requirements for a determination of optimum system function, effective plant operations, or other measures necessary to ensure the useful life of piping systems. These concerns are the responsibility of the designer and, after construction turnover, the Operating Company personnel responsible for plant activities.

Past experience has shown that a need exists for the definition of acceptable plant practices for achieving both reliable service and a predictable life in the operation of power piping systems. This Appendix is intended to serve that purpose. For this objective, this Appendix is structured in three parts that recognize and address the following basic concepts.

operation: the design of a piping system is based on specified service requirements and operating limitations. Subsequent operation within these defined limits is assumed and, for some systems, will be important for an acceptable service life.

maintenance: the design of a piping system assumes that reasonable maintenance and plant service will be provided. The lack of this support will, in some cases, introduce an increasing degree of piping system life uncertainty.

modifications: future modifications of a piping system or its operational functions are not assumed in original design unless specified. Modifications must not invalidate the integrity of a piping system design.

The practices in this Appendix are recommended for all plants and systems within the scope of the Power Piping Code, both for new construction and for existing plants in operation. An acceptable implementation of these or equivalent practices will be beneficial for new systems. The application of these practices is recommended for power piping systems in operating plants.

The recommended practices in this Appendix define minimum requirements for establishing a program to accommodate the basic considerations for piping system operation, maintenance, service, modification, and component replacement.

A record-keeping program is prescribed that can serve as a point of reference for analyzing piping system distortions or potential failures. Such a program is intended to identify distortions or failures and assure compatibility between the materials and components of existing piping systems with those portions undergoing repair, replacement, or modification.

V-1 DEFINITIONS¹

Code: ASME Code for Pressure Piping, ASME B31.1 Power Piping.

component: equipment, such as vessel, piping, pump, or valve, which are combined with other components to form a system.

critical piping systems: those piping systems that are part of the feedwater-steam circuit of a steam generating power plant, and all systems which operate under two-phase flow conditions. Critical piping systems include runs of piping and their supports, restraints, and root valves. Hazardous gases and liquids, at all pressure and temperature conditions, are also included herein. The Operating Company may, in its judgment, consider other piping systems as being critical in which case it may consider them as part of this definition.

examination: an element of inspection consisting of investigation of materials, components, supplies, or services to determine conformance to those specified requirements which can be determined by such investigation. Examination is usually nondestructive and includes simple physical manipulation, gaging, and measurement.

failure: physical condition that renders a system, component, or support inoperable.

maintenance: actions required to assure reliable and continued operation of a power plant, including care, repair, and replacement of installed systems.

modification: change in piping design or operation and accomplished in accordance with the requirements and limitations of the Code.

procedure: document that specifies or describes how an activity is to be performed. It may include methods to

¹ The definitions pertain specifically to this Appendix.

be employed, equipment or materials to be used, and sequences of operations.

qualification (personnel): demonstration of the abilities gained through training and/or experience that enable an individual to perform a required function.

renewal: activity that discards an existing component and replaces it with new or existing spare materials of the same or better qualities as the original component.

repair: to restore the system or component to its designed operating condition as necessary to meet all Code requirements.

specification: a set of requirements to be satisfied by a product, material, or process, indicating, whenever appropriate, the procedure by means of which it may be determined whether the requirements given are satisfied.

V-2 GENERAL

V-2.1 Application

V-2.1.1 This Appendix recommends minimum requirements for programs to operate and maintain ASME B31.1 Power Piping systems and also for the repairs to these systems.

V-2.1.2 Local conditions and the location of piping systems (such as indoors, outdoors, in trenches, or buried) will have considerable bearing on the approach to any particular operating and maintenance procedure. Accordingly, the methods and procedures set forth herein serve as a general guide. The Operating Company is responsible for the inspection, testing, operation, and maintenance of the piping system and shall have the responsibility for taking prudent action to deal with inherent plant conditions.

V-2.2 Conformance

V-2.2.1 When conformance with time periods for examination recommended in this document is impractical, an extension may be taken if an evaluation demonstrates that no safety hazard is present.

V-2.3 Requirements

V-2.3.1 This Appendix recommends that the following listed items be established and implemented:

(A) complete design and installation records of the "as built" large bore piping systems, including expansion joints, hangers, restraints, and other supporting components. The Operating Company shall define those sizes considered to be large bore pipe.

(B) records of operation and maintenance history.

(C) programs for periodic inspection and monitoring.

(D) procedures for reporting and analyzing failures.

(E) procedures for maintenance, repairs, and replacements.

(F) procedures for abandoning piping systems and for maintaining piping systems in and out-of-service condition.

(G) procedures for assuring that all personnel engaged in direct maintenance of such piping systems as defined in para. V-5.2.1(C) are qualified by training or experience for their tasks or work.

V-3 OPERATING AND MAINTENANCE PROGRAM

V-3.1 General

(16)

Each Operating Company shall develop an operating and maintenance program comprising a series of written procedures, keeping in mind that it is not possible to prescribe a single set of detailed operating and maintenance procedures applicable to all piping systems. The operating and maintenance procedures shall include personnel qualifications as defined by the Operating Company, material history and records, and supplementary plans to be implemented in case of piping system failures. The requirements for an operating and maintenance program for CPS are included in paras. 139, 140, 141, 142, and 144.

V-3.2 Documentation

Each plant should maintain and file the following documentation that exists for each unit:

(A) current piping drawings

(B) construction isometrics (or other drawings) that identify weld locations

(C) pipeline specifications covering material, outside diameter, and wall thickness

(D) flow diagrams

(E) support drawings

(F) support setting charts

(G) records of any piping system modifications

(H) material certification records

(I) records of operating events that exceed design criteria of the piping or supports

(J) valve data

(K) allowable reactions at piping connections to equipment

(L) welding procedures and records

V-4 REQUIREMENTS OF THE OPERATING, MAINTENANCE, AND MODIFICATION PROCEDURES

(16)

The Operating Company shall have procedures for the following, in addition to those required by paras. 139, 140, 141, and 144:

(A) to perform normal operating and maintenance work. These procedures shall include sufficiently detailed instructions for employees engaged in operating and maintaining the piping systems.

(B) to prescribe action required in the event of a piping system failure or malfunction that may jeopardize personnel safety, safe operation, or system shutdown. Procedures shall consider

(B.1) requirements defined for piping system operations and maintenance and should include failure conditions under which shutdown may be required. Procedures should include both the action required and the consequence of the action on related systems or subsystems.

(B.2) the designation of personnel responsible for the implementation of required action, and minimum requirements for the instruction, training, and qualification of these personnel.

(C) to inspect and review changes periodically in conditions affecting the safety of the piping system. These procedures shall provide for a system of reporting to a designated responsible person in order that corrective measures may be taken.

(D) to ensure that modifications are designed and implemented by qualified personnel and in accordance with the provisions of the Code.

(E) to analyze failures to determine the cause and develop corrective action to minimize the probability of recurrence.

(F) to intentionally abandon unneeded piping systems, or portions thereof, and to maintain those that are out of service for extended periods of time as defined by the Operating Company.

(G) to ensure that instruction books and manuals are consulted in performing maintenance operations.

(H) to log, file, maintain, and update instruction books.

(I) to log operating and maintenance records.

(J) to review and revise procedures periodically as dictated by experience and changes in conditions.

V-5 PIPING AND PIPE SUPPORT MAINTENANCE PROGRAM AND PERSONNEL REQUIREMENTS

V-5.1 Maintenance Program

V-5.1.1 The maintenance program shall include the following listed features:

(A) a purpose for the program

(B) the frequency for performing all elements of maintenance in the program

(C) generic requirements as related to initial hanger positions at time of unit startup, changes and adjustments in hanger positions at periodic inspections (see also section V-7), and review of manufacturer's instruction and maintenance manuals applicable to components included in the program

(D) updating and modification as may be desirable by reason of Code revisions and technological advances or other considerations

(E) steps to keep maintenance and inspection personnel aware of program revisions

V-5.2 Personnel

V-5.2.1 To the extent necessary for conformance with the maintenance program of the Operating Company, only qualified personnel shall be responsible for the following:

(A) observation, measurement, and recording the position of piping systems and support readings (see also section V-7)

(B) adjustment of supports and all other components of support and restraint systems

(C) repair and periodic maintenance routines including, but not limited to

(C.1) routine piping assembly, including welding of integral attachments

(C.2) mechanical repair of valves, traps, and similar types of piping specialty components, including packings

(C.3) removal and replacement of piping insulation

(C.4) lubrication of applicable piping and support components, such as valves and constant supports, maintenance of fluid levels in hydraulic restraints; and stroking of hydraulic and mechanical dynamic restraints (snubbers)

(C.5) routine surveillance for changing conditions including changes in position of piping and settings of piping supports and shock suppressors (snubbers)

V-6 MATERIAL RESTORATION

(16)

V-6.1 Material Condition After Failure

V-6.1.1 Defective component(s) shall be repaired or replaced with comparable or upgraded materials permissible by this Code after evaluation of the failure and taking into account conclusions as to cause. Even when materials are replaced by same or upgraded items, a formal failure report should follow.

V-6.1.2 Care shall be exercised when replacing system components to ensure no parts of the system are overstressed. The stresses in the repaired system shall be equal to or less than the original stresses unless analysis permits increased stresses. During the replacement of the component, the piping system should be temporarily supported or restrained on both sides of the component to be removed so as to maintain its as-found cold position until the component(s) is (are) installed. If the desired piping position cannot be maintained, an analysis shall be made to determine the reason for the problem. A new stress analysis may be necessary. Care shall be exercised when working on a system that has been subjected to self-springing, relaxation, or cold pull.

V-6.1.3 Weld preparations and fit-up of the weld joints shall meet the requirements of Chapter V.

V-6.1.4 Welding procedures and preheat/postheat treatments of the weld joints shall meet the minimum requirements of Chapter V.

V-6.2 Inspection Program for Materials With Adverse History

V-6.2.1 Materials that have been reported to the industry to exhibit an adverse performance under certain conditions shall be given special attention by the Operating Company through a program of planned examination and testing. This program shall include the development of procedures for repair or replacement of the material when the Operating Company determines that such action is necessary.

V-6.2.2 Methods of surveillance and analysis shall be determined by the Operating Company.

V-6.2.3 The frequency of the material inspection shall also consider the expected service life of the component.

V-6.3 Nondestructive Examination

Nondestructive examinations used to investigate any suspect materials or problem areas shall be in accordance with Chapter VI.

Other techniques or acceptance criteria may be used when appropriate for the investigation being performed and when approved by the owner.

V-7 CPS POSITION HISTORY

V-7.1 General

V-7.1.1 The Operating Company shall develop and implement a program and procedures requiring recording and documentation of piping support observations and piping displacements. This program should include, at a minimum, CPS operating in the creep range. Records should be kept and maintained of position indicator readings, load adjustments, travel adjustments, repairs, and replacements.

V-7.1.2 Although the Code recognizes that CPS pipe supports seldom return to their exact original positions after each heat cycle, piping system displacements should be maintained within the bounds of engineering-evaluated limitations.

V-7.1.3 Documentation of the piping support observations and piping displacements should be performed on a periodic basis. Each set of hot and cold walkdowns should not exceed 5-yr intervals (typically associated with a scheduled major outage). Specific unit walkdown intervals are determined by the Operating Company. The intervals may be dependent on previous walkdown and NDE results, unit operating conditions, environment, and industry experience with specific piping or pipe supports. If a set of hot and cold walkdowns

is not performed within 5 yr, the justification should be documented.

V-7.2 Visual Survey

The CPS should be observed visually, as frequently as deemed necessary. Any unusual conditions should be brought to the attention of plant management personnel as prescribed in the procedures of para. V-3.1. Observations should include determination of interferences with or from other piping or equipment, vibrations, and general condition of the piping system and supports, including but not limited to hangers, guides, restraints, anchors, supplementary steel, and attachments.

V-7.3 Piping Position Markers

V-7.3.1 Piping position and displacements may be monitored periodically at selected locations to document field conditions and to identify any migration beyond the bounds of engineering-evaluated limitations. For the purpose of easily making periodic position determinations at the selected locations, permanent markings or pointers may be attached to piping components. The positions of these markings or pointers should be noted and recorded with respect to stationary datum reference points.

V-7.3.2 Placement of pointers should be such that personnel safety hazards are not created.

V-7.4 Pipe Supports on CPS

V-7.4.1 Pipe support readings should be observed and recorded periodically. Piping system anomalies, such as interferences and lagging/insulation damage, should also be noted and recorded. Readings should be obtained while the piping is within the range of normal operating temperatures. The online pipe temperature range during the time of reading supports should be recorded. Walkdowns during unit shutdown should also be performed when the pipe is sufficiently cool [approximately 100°F (38°C) or below]. In addition to online and off-line walkdowns, a post-adjustment walkdown of the adjusted and adjacent supports should be performed. Walkdowns should be scheduled to evaluate the most critical operation scenarios; readings associated with each critical operation mode should be documented.

V-7.4.2 Variable and constant spring supports, dynamic restraints and snubbers, sliding supports, and rigid rod supports should be maintained so that they function as designed and within the limits specified by the manufacturers and designers. Maintenance of these items may include, but not necessarily be limited to, cleaning, lubrication, and corrosion protection. Snubbers should be examined and tested periodically in accordance with the manufacturer's recommendations to assure that they travel freely without binding and lock up within design parameters.

V-7.5 CPS Records

CPS support design details may be documented as provided in Form V-7.5(A). Records of position settings of all constant and variable spring supports and of all snubbers should be made before initial startup of the plant. Pipe position indicator readings, as observed on the travel scales of variable and constant spring supports, should be recorded in a manner that can be easily interpreted. The condition of rigid rod and sliding supports should also be recorded on walkdown logs. As examples, a suggested support hot walkdown record form is provided in Form V-7.5(B) and a suggested support cold walkdown record form is provided in Form V-7.5(C). The walkdown log sheet information may be organized and postprocessed on electronic media as part of the engineering evaluation process.

The log sheets should be accompanied by a pipe-support location plan or piping-system isometric drawing with hanger mark number designations clearly noted. Records should include positions of sliding supports and snubbers in the hot and cold (operating and shutdown) conditions. Records should be maintained showing axial and lateral displacements in expansion joints, including records of hot and cold (operating and shutdown) positions, particularly those not equipped with control rods or gimbals. If necessary, robust reference markings should be created for measuring differential displacements. Physical measurement records should include a description of location and measurement setup. Any adjustments to pipe support travel and load ratings should be documented.

V-7.6 Recommendations

After complete examination of the records of observations made in accordance with para. V-7.5, recommendations for necessary corrective actions should be made by a qualified individual. Evaluations, repairs, and/or modifications should be carried out by qualified personnel for all of the following discrepancies:

- (A) excessively corroded support components
- (B) broken springs or any damaged hardware that is part of the complete support assembly
- (C) excessive piping vibration; valve operator shaking or movements
- (D) piping interferences
- (E) excessive piping deflection that may require the installation of spring supports having a greater travel range or higher spring constant, or sliding support redesign
- (F) significantly reduced or increased movement compared to the expected design movement (e.g., the maximum of more than 20% variation or $\frac{1}{2}$ in. from the expected travel)
- (G) pipe sagging that may require support adjustment or the reanalysis and redesign of the support system

(H) spring support unit riding at either the top or the bottom of the available travel

(I) need for adjustment of spring support load-carrying capacity

(J) need for adjustments of support rods or turnbuckle

(K) loose or broken anchors

(L) inadequate clearances at guides or limit stops

(M) inadequate clearances between safety valve vent pipes, discharge elbows, and drip pans

(N) any failed or deformed support or support component (e.g., hanger, guide, U-bolt, anchor, snubber or shock absorber, dampener, and slide support) or supporting steel

(O) unacceptable movement in expansion joints

(P) low fluid levels in hydraulic pipe restraints

(Q) severely damaged or missing lagging and insulation

V-8 PIPING CORROSION

V-8.1 General

V-8.1.1 This section pertains to the requirements for inspection of critical piping systems that may be subject to internal or external corrosion-erosion, such as buried pipe, piping in a corrosive atmosphere, or piping having corrosive or erosive contents. Requirements for inspection of piping systems to detect wall thinning of piping and piping components due to erosion/corrosion, or flow-assisted corrosion, are also included. Erosion/corrosion of carbon steel piping may occur at locations where high fluid velocity exists adjacent to the metal surface, either due to high velocity or the presence of some flow discontinuity (elbow, reducer, expander, tee, control valve, etc.) causing high levels of local turbulence. The erosion/corrosion process may be associated with wet steam or high purity, low oxygen content water systems. Damage may occur under both single and two-phase flow conditions. Piping systems that may be damaged by erosion/corrosion include, but are not limited to, feedwater, condensate, heater drains, and wet steam extraction lines. Maintenance of corrosion control equipment and devices is also part of this section. Measures in addition to those listed herein may be required.

V-8.1.2 Where corrosion is cited in this section, it is to be construed to include any mechanism of corrosion and/or erosion. Recommended methods for monitoring and detection, acceptance standards, and repair/replacement procedures for piping components subjected to various erosion/corrosion mechanisms, including flow-assisted corrosion, are provided in Nonmandatory Appendix IV.

V-8.1.3 Guidance for the evaluation and monitoring of carbon steel piping susceptible to erosion/corrosion (flow assisted corrosion) is provided in Nonmandatory Appendix IV, para. IV-5.

V-8.2 Procedures

V-8.2.1 The Operating Company shall establish procedures to cover the requirements of this paragraph.

V-8.2.2 Procedures shall be carried out by or under the direction of persons qualified by training or experience in corrosion control and evaluation of piping systems for corrosion damage.

V-8.2.3 Procedures for corrosion control shall include, but not be limited to, the following:

(A) maintenance painting to resist external ambient conditions

(B) coating and/or wrapping for external protection of buried or submerged systems

(C) lining to resist internal corrosion from system fluid when applicable

(D) determining the amount of corrosion or erosion of the piping system internals caused by the flowing fluid

(E) determining the amount of external corrosion caused by ambient conditions, such as atmosphere, buried in soil, installed in tunnels or covered trenches, and submerged underwater

(F) preparing records that shall include all known leakage information, type of repair made, location of cathodically protected pipe, and the locations of cathodic protection facilities including anodes

(G) examining records from previous inspection and performing additional inspections where needed for historical records

V-8.3 Records

V-8.3.1 Tests, surveys, and inspection records to indicate the adequacy of corrosion control shall be maintained for the service life of the piping system. This should include records of measured wall thickness and rates of corrosion.

V-8.3.2 Inspection and maintenance records of cathodic protection systems shall be maintained for the service life of the protected piping.

V-8.3.3 Observations of the evidence of corrosion found during maintenance or revision to a piping system shall be recorded.

V-8.4 Examination of Records

V-8.4.1 Records shall be examined and evaluated by trained personnel.

V-8.4.2 Where inspections or leakage history indicate that active corrosion is taking place to the extent that a safety hazard is likely to result, applicable portions of the system shall be replaced with corrosion resistant materials or with materials which are protected from corrosion, or other suitable modifications shall be made.

V-8.5 Frequency of Examination

V-8.5.1 Within 3 yr after original installation, each piping system shall be examined for evidence of corrosion in accordance with the requirements established by the Operating Company's procedures. Piping in severe service or environmental conditions should be inspected initially within a time frame commensurate with the severity of the service or environment. Corrective measures shall be taken if corrosion is above the amount allowed for in the original design.

V-8.5.2 Continued examination shall be made at intervals based upon the results of the initial inspection, but not to exceed 5 yr, with corrective measures being taken each time that active corrosion is found.

V-8.5.3 Examination for evidence of internal corrosion shall be made by one of the following:

(A) drilled hole with subsequent plugging

(B) ultrasonic test for wall thickness determination

(C) removal of representative pipe section at flange connections or couplings

(D) removal of short section of pipe

(E) radiography for evidence of wall thinning

(F) borescope or videoprobe examination

(G) a method equivalent to those above

V-8.5.4 Examinations for evidence of external corrosion shall be made after removal of covering, insulation or soil on a representative short section of the piping system taking into consideration varying soil conditions.

V-9 PIPING ADDITION TO EXISTING PLANTS

V-9.1 Piping Classification

Piping and piping components that are replaced, modified, or added to existing piping systems are to conform to the edition and addenda of the Code used for design and construction of the original systems, or to later Code editions or addenda as determined by the Operating Company. Any additional piping systems installed in existing plants shall be considered as new piping and shall conform to the latest issue of the Code.

V-9.2 Duplicate Components

Duplicates of original components and materials are permitted for permanent replacements, provided the renewal is a result of reasonable wear and not the result of the improper application of the material, such as temperature and corrosive environment.

V-9.3 Replacement Piping and Piping Components

Where replacement components differ from the original components with respect to weight, dimensions, layout, or material, the design of the affected piping system

shall be rechecked for the following design considerations:

(A) Hangers and supports shall be adequate for additional or altered distribution of weight. They shall accommodate the flexibility characteristics of the altered piping system.

(B) Changes in stresses imposed on both existing and replacement components of the piping shall be evaluated and compensation shall be made to prevent overstress in any part of the entire altered piping system.

(16) V-10 PRESSURE RELIEF DEVICES

V-10.1 General

This section is applicable to pressure relief devices (PRDs) as defined by ASME PTC 25, Pressure Relief Devices. Except as otherwise noted, or as applicable, all references to PRDs shall be considered to include both reclosing and nonreclosing PRDs. PRDs shall be maintained in good working condition. Also, discharge pipes and their supports shall be inspected routinely and maintained properly. Any evidence of blowback at the drip pan of open PRD vent systems should be noted and its cause determined and corrected. Precautionary safeguards should be considered and provided to protect against the detrimental impact of discharge from PRDs on personnel and other equipment located in the surrounding area. These safeguards should also consider the impact from discharge that may prevent or restrict personnel from taking corrective actions necessary to permit the continued safe operation of the PRD vent systems and other nearby equipment.

V-10.2 Inspection, Testing, and Adjustment

V-10.2.1 Determination of appropriate inspection and testing of PRDs for pressure setting or functionality shall be in accordance with written procedures that incorporate the requirements of regulatory agencies, operational history and previous inspection results, jurisdictional requirements, and manufacturer's instructions. Inspection and applicable online testing should be performed and documented just prior to a planned outage so that any required repair or maintenance, except spring and blowdown ring adjustments, can be performed during the outage, thereby assuring tight devices upon return to service. It is recommended that all rupture disks and breaking pin type devices be replaced periodically to prevent unintended and premature failure.

V-10.2.2 The setting or adjustment of PRDs shall be done by personnel trained in the operation and maintenance of such devices. PRDs, as applicable, shall be tested after any change in setting of the spring or blowdown ring. Appropriate seals should be used to assure that there is no unauthorized tampering with the device settings. Repairs to PRDs and disassembly, reassembly, and/or adjustments affecting the pressure relief device function,

which are considered a repair, should be performed by an authorized repair organization.²

V-10.3 Operation

The precautions stated in the manufacturer's operating manual or instruction books shall be followed when operating valve-type PRDs. In general, these precautions will include the following:

(A) Hand lifting is permitted. Assistance, as required, may be accomplished by the use of small wires or chains.

(B) Striking or hammering the valve body shall not be permitted. Only the hand-test lever shall be used.

(C) Attempts to stop leakage through the valve seat shall not be made by compressing the spring.

V-11 DYNAMIC LOADING

Evidence of excessive dynamic loading may include, but is not limited to, observation of abnormal piping motion, abnormal sounds from the piping, insulation damage, permanent displacement of piping, distortion of pipe hangers/supports/restraints, fluid links, and distortion of structural steel.

V-11.1 Water Hammer

V-11.1.1 Water hammer includes any water or other liquid transient event such as pressure surge or impact loading resulting from sudden or momentary change in flow or flow direction.

V-11.1.2 Water hammer could be the result of an incorrectly sloped pipe intended for steam condensate drainage. Water hammer problems resulting from accumulated condensate in a steam line cannot be solved simply by adding restraints. Corrective action may include changing line slopes, adding drain pots, adding warm-up lines around valves, checking for leaking desuperheaters, faulty electrical controls on automatic drains, etc.

V-11.1.3 Water hammer due to column separation in feedwater or booster pump suction piping results when the deaerator pegging pressure is not maintained. This type of water hammer can be particularly severe and requires prompt attention to control and reduce it.

V-11.1.4 As a priority, corrective action should address the cause of water hammer first. If such corrective action is ineffective in reducing the effects of water hammer to acceptable levels, installation of restraints may be necessary to limit piping displacements and/or damage from fatigue.

² Examples of organizations that may be authorized by the owner, or by the local jurisdiction, to perform repairs on PRDs include, but are not limited to, the original device manufacturer or a repair organization that holds a National Board of Boiler and Pressure Vessel Inspectors (NB-23) VR stamp.

V-11.2 Steam Hammer

Dynamic loads due to rapid changes in flow conditions and fluid state in a steam piping system are generally called steam hammer loads. Piping response to these momentary unbalanced loads can be significant in high-pressure steam systems, e.g., main steam, hot and cold reheat steam, bypass, and auxiliary steam systems that are subject to rapid interruption or establishment of full steam flow.

V-12 CREEP

V-12.1 General

V-12.1.1 For materials operating in the creep regime, accelerated creep damage, including rupture, can occur from prolonged operation at high stress levels. Furthermore, creep damage can be accelerated through prolonged exposure to temperatures or pressures above design values.

Since creep damage is time dependent, the Operating Company should periodically select high-priority creep damage areas for examination, based on the guidelines provided in para. V-12.2.

V-12.1.2 The effect of temperature on the time to failure due to creep is illustrated in Fig. V-12.1.2. As an example, based on $1\frac{1}{4}\text{Cr}-\frac{1}{2}\text{Mo}$ and $2\frac{1}{4}\text{Cr}-1\text{Mo}$ material creep rupture properties, this figure indicates the appropriate percentage change in the time to failure for variations in the steady operating temperature.

For example, a component constantly operates at a specific temperature, X , that is within the material creep regime. If the component continuously operates at 5°C (9°F) below X , the time to failure due to creep is increased by about 45%. If the component continuously operates at 5°C (9°F) above X , the time to failure is decreased by about 30%.

V-12.1.3 The remaining useful life may be estimated by determining the extent of current creep damage in the pipe and weldment materials and predicting future damage by considering the expected temperature and stress conditions for the service-degraded material.

V-12.2 Procedures

V-12.2.1 The Operating Company shall develop a program and procedures to determine the extent of creep damage. The procedures shall be carried out by, or under the direction of, persons qualified by training and experience in the evaluation of creep effects in power plant piping. The NDE and evaluation procedures may include the following considerations:

(A) a review of prior NDE results to determine the extent of prior creep damage.

(B) liquid penetrant, magnetic particle, radiographic, ultrasonic examination, and other NDE methods

approved by the Operating Company may be used to detect surface and internal cracks.

(C) diametral measurements may be used to detect creep swelling.

(D) an examination of the microstructure to determine the degree of material degradation. This can be performed by surface replication techniques, metallography using specimens obtained by boat-sampling or trepanning, and other methods approved by the Operating Company.

V-12.2.2 A procedure should be developed to select piping system areas more likely to have greater creep damage. The procedures should include an evaluation process, which may include a review of

(A) material specifications

(B) operating stress levels

(C) previous walkdown results (considering noted anomalies)

(D) NDE results

(E) operating history (including temperature, pressure, and severe transient events)

(F) cycles (for creep-fatigue interaction)

(G) maintenance history

(H) industry experience

The procedure should establish a prioritized examination schedule based on the evaluation process. Following an examination, the evaluation process should be periodically repeated to select subsequent sets of high-priority creep damage areas. The frequency of examination shall be in accordance with para. V-12.5.

To evaluate the potential for accelerated creep damage in longitudinal seam welds, para. 102.4.7 may be used to provide seam weld strength reduction factors.

V-12.3 Records

Records of creep damage survey findings and evaluations shall be maintained in accordance with paras. 140 and 141.

V-12.4 Examination of Records

V-12.4.1 Records of creep damage surveys and test reports shall be examined by personnel qualified, by training and experience, to evaluate and interpret NDE and metallographic studies.

V-12.4.2 Where surveys and examinations of piping systems operating in the creep range indicate that creep damage has progressed to an unacceptable level (determined by the Operating Company), those portions of the piping system shall be considered for more extensive evaluations or replacement.

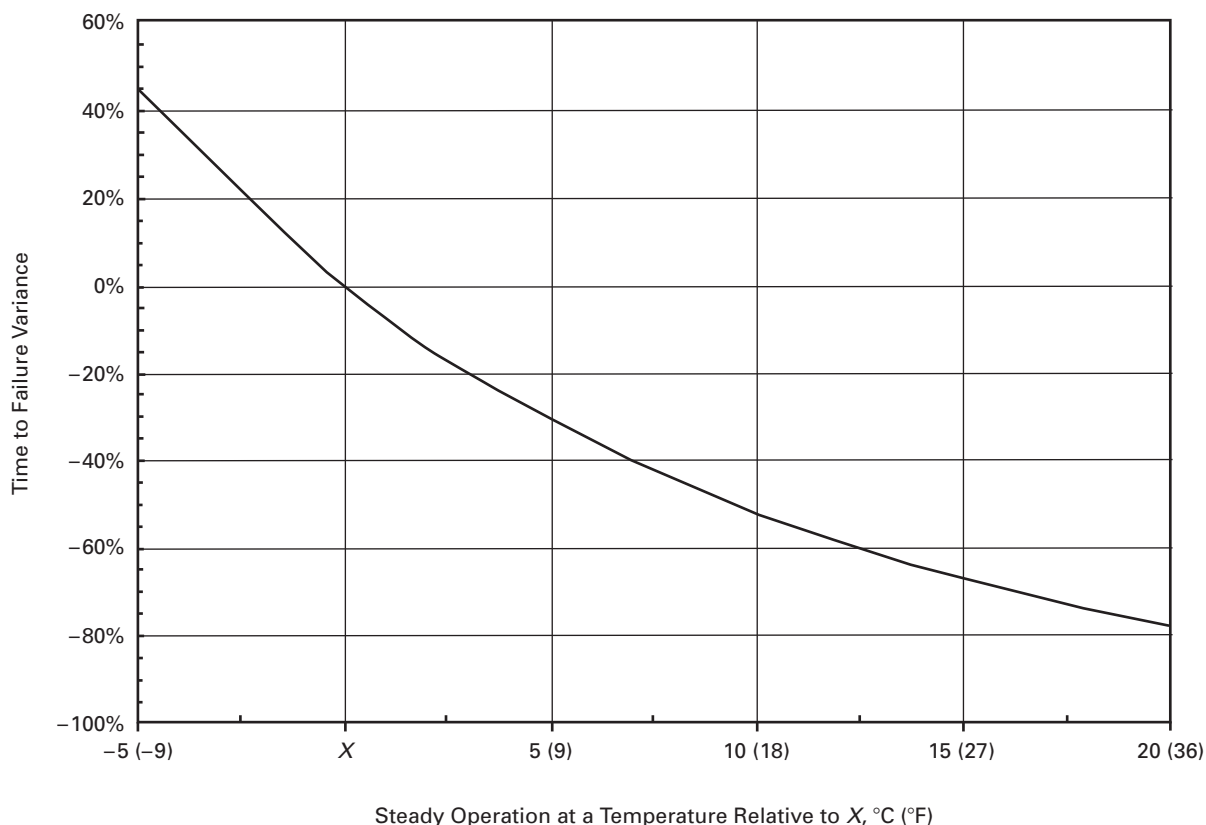
Fig. V-12.1.2 Effect of Various Steady Operating Temperatures on Time to Failure Due to Creep**GENERAL NOTES:**

- (a) This Figure illustrates the significant effect of temperature variance on time to failure due to creep. The illustration should not be used for piping life assessment, because other attributes and fluctuations are not considered.
- (b) The curve is based on $1\frac{1}{4}\text{Cr}-\frac{1}{2}\text{Mo}$ and $2\frac{1}{4}\text{Cr}-1\text{Mo}$ material creep rupture properties.

V-12.5 Frequency of Examination

The frequency of examination, determined by the Operating Company, should be based on previous evaluation results and industry experience. Particular consideration should be given to the selected high-priority weldments.

V-13 RERATING PIPING SYSTEMS**V-13.1 Conditions**

An existing piping system may be rerated for use at a higher pressure and/or temperature if all of the following conditions are met:

(A) A design analysis shall be performed to demonstrate that the piping system meets the requirements of the Code at the new design conditions.

(B) The condition of the piping system and support/restraint scheme shall be determined by field inspections and the examination of maintenance records, manufacturer's certifications, and/or other available information to ensure conformance with the Code requirements for the new design conditions.

(C) Necessary repairs, replacements, or alterations to the piping system are made to conform with the requirements prescribed in (A) and (B) above.

(D) The system has been leak tested to a pressure equal to or greater than that required by the Code for a new piping system at the new design conditions.

(E) The rate of pressure and temperature increase to the higher maximum allowable operating conditions shall be gradual so as to allow sufficient time for periodic observations of the piping system movements and leak tightness.

(F) Records of investigations, work performed, and pressure tests conducted in rerating the piping systems shall be preserved for the service life of the piping systems.

(G) All safety valves, relief valves, and other pressure relieving devices must be examined, and recertified for the new pressure/temperature design conditions. Capacity of relieving equipment shall be investigated if the design pressure and/or temperature are changed in rerating a piping system.

(16) **V-14 REPAIR OF PIPING SYSTEMS**

V-14.1 Guidance for Repairs

The referenced standards/codes listed below may be used by the Operating Company to assist in the preparation of repair procedures. This list is not intended to be all-inclusive, nor should it be considered an endorsement of the listed referenced standard. Jurisdictional requirements may also apply and should be reviewed prior to making any repairs.

(A) ASME PCC-2, Repair of Pressure Equipment and Piping

(B) ANSI/NB-23, National Board Inspection Code — Part 3: Repairs and Alterations

(C) API 570, Piping Inspection Code: In-service Inspection, Rating, Repair, and Alteration of Piping Systems

NONMANDATORY APPENDIX VI APPROVAL OF NEW MATERIALS

The ASME B31.1 Committee considers requests for adoption of new materials desired by the owner/user or fabricator, manufacturer, installer, assembler of piping or piping components constructed to the Code. For the material to receive proper consideration, information and data are required to categorize the material properly. In general this information and data include, but are not necessarily limited to, the following:

(A) the chemical composition of the material including those elements that establish the characteristics and behavior of the material.

(B) the mechanical properties of the material, including tensile test data, ductility data, and other special mechanical test data, which will assist the Committee in its review of the material and its application.

(B.1) tensile test data (per ASTM E21), including both ultimate tensile strength and yield strength, at room temperature and at 100°F or 50°C intervals to a temperature at least 100°F higher than the intended use of the material.

(B.2) when creep properties are expected to limit the allowable stress, creep and creep rupture data at temperature intervals of 100°F or 50°C are also required. Such data should be for four or more time intervals, one of which should be longer than 2,000 hr but less than 6,000 hr, and one of which should be longer than 6,000 hr.

(C) if the material is to be used in welded construction, data from actual welding tests made in accordance with Section IX of the ASME Boiler and Pressure Vessel Code (BPVC) should be submitted. Welding test data should include

(C.1) the welding processes and weld filler metal(s) intended for the fabrication of the material.

(C.2) all-weld-metal tensile test data for temperatures representative of intended service.

(C.3) any special restrictions on the welding of the material.

(C.4) the appropriate preheat and postweld heat treatment, if any, which will be given the material. If postweld heat treatment results in embrittlement of the material, the significance of such treatments with substantiating data should be forwarded. Toughness data on weld metal and heat affected zone in the as-welded and postweld heat treated conditions, when appropriate, should be submitted.

(D) where the material is intended for special applications, requires special handling or special welding procedures, or has known limitations or susceptibility to

failure in certain services, precautionary requirements and information should also be submitted for review by the Committee.

(E) applicable product form(s) of the material, such as sheet, strip, plate, bars, shapes, seamless or welded pipe or tube forgings, castings, etc., for which application is to be considered must be identified.

The general data recommended should be submitted on a minimum of three heats, preferably commercial heats, of the material. Where the range of chemical composition affects the mechanical properties, the heats selected should cover both the high and low range of the effective chemical elements to show the effect on the mechanical properties. Any special heat treatment, whether applied by the material supplier or the fabricator, should be applied to the test pieces used to obtain the data.

If the material is covered by an ASTM specification, the specification number(s) and grade(s) involved must be identified in the application. If the material is not covered by an ASTM specification, application must be made to ASTM for specification coverage of this material.

Should there be a need for Code use prior to the inclusion of the material in ASTM specifications, the Committee will consider issuing a Code Case.

In addition to the information and data noted above, the Committee should be provided with an indication of user need, a copy of the letter to ASTM requesting specification coverage, and sufficient information for the Committee to modify an appropriate existing ASTM specification to establish the material specification requirements for the material product form.

When the new material is a minor modification of a material that is currently accepted by the Code, the data required may be reduced with the concurrence of the Committee.

If it is desired that the material be permitted for use in Boiler External Piping, this should be noted in the request. The request should indicate whether the material is currently permitted for use by ASME BPVC Section I or an ASME BPVC Section I Code Case and whether a request has been made or will be made to Section I to consider permitting the use of the material. The request shall indicate the intended application and range of service temperatures for the material. In determining whether a material should be permitted to

be used in Boiler External Piping, the Committee will consider the following and other pertinent factors:

- whether the material is permitted to be used by ASME BPVC Section I
- whether the material is essentially the same as a material permitted to be used by ASME BPVC Section I
 - the experience base for the use of the material
 - whether the material is seam welded with filler metal added (seam-welded pipe with filler metal added is generally not permitted)

- whether the material is intended for use in water-wetted service and is austenitic stainless steel (austenitic stainless steels are generally not permitted in water-wetted service)

When the data supplied are insufficient for an adequate evaluation, the Committee will request additional data. Such requests will be returned, indicating those areas in which additional information is required.

NONMANDATORY APPENDIX VII

PROCEDURES FOR THE DESIGN OF RESTRAINED UNDERGROUND PIPING

FOREWORD

The Code contains rules governing the design, fabrication, materials, erection, and examination of power piping systems. Experience over the years has demonstrated that these rules may be conservatively applied to the design and analysis of buried piping systems. However, the ASME B31.1 rules were written for piping suspended in open space, with the supports located at local points on the pipe. Buried piping, on the other hand, is supported, confined, and restrained continuously by the passive effects of the backfill and the trench bedding. The effects of continuous restraint cannot be easily evaluated by the usual methods applied to exposed piping, since these methods cannot easily accommodate the effects of bearing and friction at the pipe/soil interface. Accordingly, this Appendix has been prepared to illustrate and clarify the application of Code rules to restrained buried piping.

All components in the buried piping system must be given consideration, including the building penetrations, branches, bends, elbows, flanges, valves, grade penetrations, and tank attachments. It is assumed that welds are made in accordance with this Code and that appropriate corrosion protection procedures are followed for buried piping.

This Appendix provides analytic and nomenclature definition figures to assist the designer, and is not intended to provide actual design layout. Sample calculations for various configurations of semirigid buried piping have been provided at the end of the text to assist the designer in the application of these procedures.

VII-1 SCOPE AND DEFINITIONS

VII-1.1 Scope

The scope of this Appendix is confined to the design of buried piping as defined in para. VII-1.2. Thermal expansion in buried piping affects the forces, the resulting bending moments and stresses throughout the buried portions of the system, particularly at the anchors, building penetrations, buried elbows and bends, and branch connections, and it is the designer's responsibility to consider these forces. This Appendix, however, deals only with the buried portions of the system, and not the complete system.

The design and analysis of buried piping requires that careful attention be paid to

- (A) all loads acting on the system
- (B) the forces and the bending moments in the piping and piping components resulting from the loads
- (C) the loading and stress criteria
- (D) general design practices

VII-1.2 Definitions

confining pressure: the pressure imposed by the compacted backfill and overburden on a buried pipe. Confining pressure is assumed to act normal to the pipe circumference.

flexible coupling: a piping component that permits a small amount of axial or angular movement while maintaining the pressure boundary.

friction: the passive resistance of soil to axial movement. Friction at the pipe/soil interface is a function of confining pressure and the coefficient of friction between the pipe and the backfill material. Friction forces exist only where there is actual or impending slippage between the pipe and soil.

influence length: that portion of a transverse pipe run which is deflected or "influenced" by pipe thermal expansion along the axis of the longitudinal run.

modulus of subgrade reaction: the rate of change of soil bearing stress with respect to compressive deformation of the soil. It is used to calculate the passive spring rate of the soil.

penetration: the point at which a buried pipe enters the soil either at grade or from a wall or discharge structure.

settlement: the changes in volume of soil under constant load that result in the downward movement, over a period of time, of a structure or vessel resting on the soil.

virtual anchor: a point or region along the axis of a buried pipe where there is no relative motion at the pipe/soil interface.

VII-1.3 Nomenclature

- A = cross-sectional metal area of pipe, in.²
- A_c = surface area of a 1-in. long pipe segment, in.²
- a, b, c = quadratic equation functions
- B_d = trench width at grade, in.

C_D = soil bearing parameter from Table VII-3.2.3, dimensionless
 C_k = horizontal stiffness factor for backfill [8],¹ dimensionless
 D = pipe outside diameter, in.
 dL = length of pipe element, in.
 E = Young's modulus for pipe, psi
 F_f = total friction force along effective length, lb
 F_{\max} = maximum axial force in pipe, lb
 f = unit friction force along pipe, lb/in.
 f_{\min}, f_{\max} = minimum, maximum unit friction force on pipe, lb/in.
 H = pipe depth below grade, in.
 I = pipe section moment of inertia, in.⁴
 k = soil modulus of subgrade reaction, psi
 k_h = soil horizontal modulus of subgrade reaction, psi
 $k_{i,j}$ = orthogonal soil springs on pipe, lb/in.
 k_v = soil vertical modulus of subgrade reaction, psi
 L_1 = length of transverse pipe run, in.
 L_2 = length of longitudinal pipe run, in.
 L_m = minimum slippage length of pipe, in.
 L' = effective slippage length for short pipes, in.
 L'' = effective slippage length for long pipes, in.
 N_h = horizontal force factor [8], dimensionless
 n = number of modeling elements for pipe springs, dimensionless
 P = maximum operating pressure in pipe, psi
 P_c = confining pressure of backfill on pipe, psi
 S_A = allowable expansion stress range, psi
 SE = expansion stress, psi
 S_h = basic material allowable stress at T degrees Fahrenheit, psi
 T = maximum operating temperature, °F
 T_o = ambient temperature of pipe, °F
 t = pipe wall thickness, in.
 W_p = unit weight of pipe and contents, lb/in.
 w = soil density, lb/ft³, lb/in.³
 α = coefficient of thermal expansion of pipe, in./in./°F
 β = pipe/soil system characteristic [2], in.⁻¹
 ϵ = pipe unit thermal expansion, in./in.
 μ = coefficient of friction, dimensionless
 Ω = effective length parameter, in.

VII-2 LOADS

VII-2.1 Thermal Expansion

Thermal displacements at the elbows, branch connections, and flanges in a buried piping system and the forces and moments resulting from the displacements may be determined by analyzing each buried run of pipe by the method described in this Appendix.

VII-2.1.1 Installations With Continuous Runs. For buried piping installations that contain continuous runs without flexible couplings, the passive restraining effects of soil bearing on the transverse legs at the ends of long runs subject to thermal expansion may be significant and result in high axial forces and elbow or branch connection bending moments.

VII-2.1.2 Installations With Flexible Couplings. For buried piping installations that incorporate flexible couplings into the pipe runs subject to thermal expansion, the bending moments and stresses may be substantially reduced. However, the flexible couplings must be chosen carefully to accommodate the thermal expansion in the pipe, and the friction forces or stiffness in the coupling must be considered.

VII-2.1.3 Installations With Penetration Anchors. For buried piping systems in which the building penetration provides complete restraint to the pipe, it is necessary to calculate the penetration reactions to thermal expansion in the initial buried run. If this run incorporates flexible couplings, piping reactions at the penetration resulting from unbalanced forces due to internal pressure must be considered.

VII-2.1.4 Installations With Flexible Penetrations. For buried piping systems in which the building penetrations permit some axial or angular movements, the interaction between the buried run outside the penetration and the point-supported portion of the system inside the building must be considered.

VII-2.2 Pressure

Pressure loads in buried piping are important for two primary reasons.

VII-2.2.1 In pipe runs that incorporate flexible couplings, there is no structural tie between the coupled ends, with the result that internal pressure loads must be reacted externally. External restraint may be provided by thrust blocks, external anchors, soil resistance to elbows or fittings at each end of the pipe run, or by control rods across the coupling. Where one or both of the ends terminate at a penetration or an anchor, or at connected equipment such as a pump or vessel, the pressure forces can be quite high and must be considered in the anchor or equipment design.

¹ Numbers enclosed in brackets [] correspond to references cited in para. VII-7.

VII-2.2.2 For discharge structures, the reaction forces due to upstream pressure and mass flow momentum in the discharge leg may be high and must be considered in the design of the last elbow or bend before the discharge.

VII-2.3 Earthquake

An earthquake subjects buried piping to axial loads and bending moments from soil strain due to seismic waves, or from ground faulting across the axis of the pipe. The seismic soil strain can be estimated for a design earthquake in a specific geographical region, from which design values for forces and moments in buried piping can be calculated. However, consideration of the magnitude and effects of seismic ground faulting on buried piping is beyond the scope of this Appendix.

VII-3 CALCULATIONS

The calculations for stresses in restrained underground piping are carried out in four steps, as follows.

VII-3.1 Assembling the Data

The pipe material and dimensions, soil characteristics, and operating conditions must be established.

VII-3.1.1 Pipe Data

- (A) pipe outside diameter, D , in.
- (B) wall thickness, t , in.
- (C) length of pipe runs, L_1 (transverse) and L_2 (longitudinal), in.
- (D) Young's modulus, E , psi (from Mandatory Appendix C)
- (E) pipe depth below grade, H , in.

VII-3.1.2 Soil Characteristics

- (A) soil density, w , lb/ft³ (from site tests)
- (B) type of backfill
- (C) pipe trench width at grade, B_d , in.
- (D) range of coefficient of friction, μ , between pipe and backfill

VII-3.1.3 Operating Conditions

- (A) maximum operating pressure, P , psi
- (B) maximum pipe temperature, T , °F
- (C) ambient pipe temperature, T_o , °F
- (D) pipe coefficient of thermal expansion, α , in./in./°F

VII-3.2 Calculations of Intermediate Parameters

The parameters specified in paras. VII-3.2.1 through VII-3.2.6 must be calculated.

VII-3.2.1 Maximum Relative Strain, ϵ , at the Pipe/Soil Interface, in./in. For thermal expansion, this is the unit thermal elongation of the unrestrained pipe

$$\epsilon = \alpha(T - T_o) \quad (1)$$

where

$T - T_o$ = difference between operating and installation temperatures

α = coefficient of thermal expansion

VII-3.2.2 Modulus of Subgrade Reaction, k , psi.

This is a factor which defines the resistance of the soil or backfill to pipe movement due to the bearing pressure at the pipe/soil interface. Several methods for calculating k have been developed in recent years by Audibert and Nyman [7], Trautmann and O'Rourke [8], and others [4, 5, 6]. For example [8], for pipe movement horizontally, the modulus of subgrade, k_h , may be found by

$$k_h = C_k N_h w D, \text{ psi} \quad (2)$$

where

C_k = a dimensionless factor for estimating horizontal stiffness of compacted backfill. C_k may be estimated at 20 for loose soil, 30 for medium soil, and 80 for dense or compacted soil.

D = pipe outside diameter, in.

N_h = a dimensionless horizontal force factor from Fig. 8 of [8]. For a typical value where the soil internal friction angle is 30 deg, the curve from [8] may be approximated by a straight line defined by

$$N_h = 0.285H/D + 4.3$$

where

H = the depth of pipe below grade at the pipe centerline, in.

w = soil density, lb/in.³

For pipe movement upward or downward, the procedures recommended in [4] may be applied. Conservatively, the resistance to upward movement may be considered the same as for horizontal movement with additional consideration for the weight of the soil. Resistance to downward movement may conservatively be considered as rigid for most expansion stress analysis.

VII-3.2.3 Unit Friction Force at the Pipe/Soil Interface, f

$$f = \mu (P_c A_c + W_p), \text{ lb/in.} \quad (3)$$

where

A_c = surface area of a pipe segment, in.²

P_c = confining pressure of soil on pipe, psi

W_p = unit weight of pipe and contents, lb/in.

μ = coefficient of friction between pipe and soil

Table VII-3.2.3 Approximate Safe Working Values of C_D for Use in Modified Marston Formula

Ratio H/B_D	Damp Top Soil and Dry and Wet Sand	Saturated Top Soil	Damp Yellow Clay	Saturated Yellow Clay
0.5	0.46	0.47	0.47	0.48
1.0	0.85	0.86	0.88	0.90
1.5	1.18	1.21	1.25	1.27
2.0	1.47	1.51	1.56	1.62
2.5	1.70	1.77	1.83	1.91
3.0	1.90	1.99	2.08	2.19
3.5	2.08	2.18	2.28	2.43
4.0	2.22	2.35	2.47	2.65
4.5	2.34	2.49	2.53	2.85
5.0	2.45	2.61	2.19	3.02
5.5	2.54	2.72	2.90	3.18
6.0	2.61	2.91	3.01	3.32
6.5	2.68	2.89	3.11	3.44
7.0	2.73	2.95	3.19	3.55
7.5	2.78	3.01	3.27	3.65
8.0	2.82	3.06	3.33	3.74
9.0	2.88	3.14	3.44	3.89
10.0	2.92	3.20	3.52	4.01
11.0	2.95	3.25	3.59	4.11
12.0	2.97	3.28	3.63	4.19
13.0	2.99	3.31	3.67	4.25
14.0	3.00	3.33	3.70	4.30
15.0	3.01	3.34	3.72	4.34
∞	3.03	3.38	3.79	4.50

For piping that is buried within 3 pipe diameters of the surface, confining pressure, P_c , may be estimated by

$$P_c = wH, \text{ lb/in.}^2$$

where

H = the depth below grade, in.

w = the soil density, lb/in.³

For piping that is buried more than 3 pipe diameters below grade, confining pressure, P_c , is found by using the modified Marston equation [9].

$$P_c = wC_D B_D, \text{ lb/in.}^2$$

where

B_D = the trench width, with a maximum value of 24 in. plus the pipe diameter

C_D = a dimensionless parameter obtained from Table VII-3.2.3

VII-3.2.4 Pipe/Soil System Characteristic [2]

$$\beta = [k/(4EI)]^{1/4}, \text{ in.}^{-1} \quad (4)$$

where

E = Young's modulus for pipe, psi

I = area moment of inertia for pipe, in.⁴

k = soil modulus of subgrade reaction k_h or k_v , psi

VII-3.2.5 Minimum Slippage Length, L_m [1]

$$L_m = \epsilon AE/f, \text{ in.} \quad (5)$$

where

A = pipe cross section area

VII-3.2.6 Maximum Axial Force, F_{\max} , in the Longitudinal Pipe Run. The maximum axial force in a pipe long enough for friction force to develop to the point where a region of the pipe is totally restrained longitudinally by the soil is found by

$$F_{\max} = fL_m = \epsilon AE, \text{ lb} \quad (6)$$

VII-3.3 Classification of the Pipe Runs

VII-3.3.1 Purpose. The classification and subclassification of the buried pipe elements is used in choosing the proper equation for effective slippage length, L' or L'' , which is then used in calculating piping forces and stresses. The pipe segment identified by the dimension L' or L'' always begins at either an elbow, bend, tee, or branch connection and terminates at the point (described below as the "virtual anchor") at which there is no slippage or relative movement at the pipe/soil interface.

VII-3.3.2 Classification of the Pipe Elements. It is in the bends, elbows, and branch connections that the highest stresses are found in buried piping subject to thermal expansion of the pipe. These stresses are due to the soil forces that bear against the transverse run (the run running perpendicular or at some angle to the direction of the pipe expansion). The stresses are proportional to the amount of soil deformation at the elbow or branch connection.

Piping elements are divided into three major categories depending upon what type of transverse element is being analyzed, as follows:

Category A: elbow or bend (see Fig. VII-3.3.2-1)

Category B: branch pipe joining the longitudinal run (see Fig. VII-3.3.2-2)

Category C: longitudinal run ending in a tee (see Fig. VII-3.3.2-3)

Category D: straight pipe, no branch or transverse run (see Fig. VII-3.3.2-4)

Categories A, B, and C are further divided into three subcategories depending on the configuration of the pipe run at the end opposite that being analyzed. The piping elements are classified as follows:

$A1, B1, C1$: other end free or terminating in a flexible coupling or joint

$A2, B2, C2$: other end contains an elbow or tee

$A3, B3, C3$: other end is anchored

Fig. VII-3.3.2-1 Element Category A, Elbow or Bend

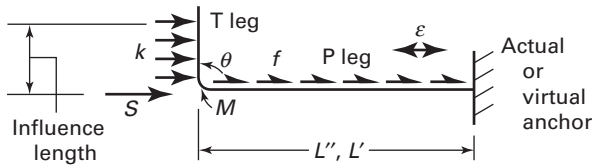

Fig. VII-3.3.2-2 Element Category B, Branch Pipe Joining the P Leg

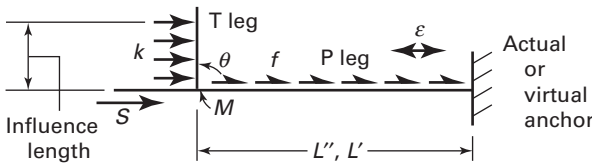

Fig. VII-3.3.2-3 Element Category C, Tee on End of P Leg

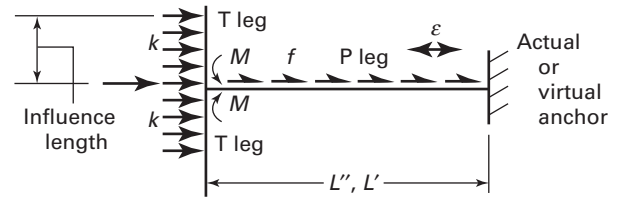
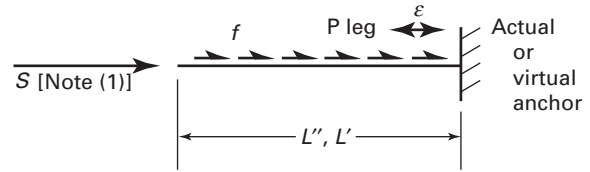

Fig. VII-3.3.2-4 Element Category D, Straight Pipe



NOTE:

(1) Expansion joint pressure load plus sliding or convolution loads.

Category D elements include straight runs between an anchor (either actual or virtual) and a free end or a pipe section that is connected to an expansion joint.

The elements are further broken down into subtypes depending upon whether the longitudinal run (the pipe or P leg) and the transverse run (called the T leg) are long or short with respect to certain criteria. The transverse or T leg is the run against which the soil bears, producing an in-plane bending moment in elbow, branch, or tee. (Category D elements have no transverse leg.)

The strict criterion for a long or short transverse leg is whether the length of the transverse run, L_1 , is longer or shorter than $3\pi/4\beta$, the length at which the hyperbolic functions in Hetenyi's equations [2] approach unit. The critical value for L_1 is often called the "influence" length, or that portion of transverse or T run which is deflected or "influenced" by seismic soil strain or pipe thermal expansion along the axis of the longitudinal or P run. In practice, a critical influence length, L_1 , of $1/\beta$ to $1.2/\beta$ may often be used, since there is very little deformation or load in that portion of the transverse run which exceeds this length. This implies that the vast majority of the bearing load on the transverse or T leg occurs in the first several feet of the pipe at the bend or branch. In summary, a transverse pipe is "long" if

$$L_1 \geq 3\pi/4\beta \text{ (conservative)}$$

or

$$L_1 \geq 1/\beta \text{ to } 1.2/\beta \text{ (usually acceptable)}$$

The criterion for a short or long P leg is whether or not its length, L_2 , is sufficiently long to experience the

maximum force that can develop at the friction interface. For full maximum friction force ($F_{\max} = \epsilon AE$) to occur in a straight pipe axially free at each end, its length, L_2 , would have to equal or exceed $2L_m$ with L_m calculated by eq. (5). If one end terminates in an elbow or a tee, with the other end remaining axially unrestrained, the total length, L_2 , necessary for full friction to develop is $L'' + L_m$; the friction force over L_m is equal to the soil bearing force S plus the friction force acting on the length L' or L'' , which is called the effective slippage length. The effective slippage length is the maximum length along which slippage occurs at the pipe/soil interface of a pipe with a transverse leg or branch. The effective slippage length, L'' , for long pipes with long transverse legs is calculated by

$$L'' = \Omega[(1 + 2F_{\max}/f\Omega)^{1/2} - 1], \text{ in.} \quad (7)$$

where

$$\Omega = AE\beta/k$$

and F_{\max} is calculated by eq. (6).

Equation (7) applies to bends, tees, and branches. Although eq. (7) was developed for the case where $L_2 = L'' + L_m$, it applies also for any case where $L_2 > L'' + L_m$, since the length of the region where there is zero slippage at the friction interface is immaterial [1]. Using L'' as calculated by eq. (7), it can now be established that a P leg is classified long if it meets the following criteria:

- (A) for Types A1, B1, C1, $L_2 \geq L_m + L''$
- (B) for Types A2, B2, C2, $L_2 \geq 2L''$
- (C) for Types A3, B3, C3, D, $L_2 \geq L''$

That point which is located a distance L' or L'' from the bend, branch, or tee, is called the virtual anchor, since it acts as if it were a three-axis restraint on the pipe.

VII-3.3.4 Locating the Virtual Anchor. Calculation of the forces and moments in buried piping at the changes in direction requires that the location of the virtual anchor (the effective slippage length, L' , away from the bend or branch element) in the P run and deformation, δ , of the soil at the buried element be established. For elements of all types with long P legs, L'' may be calculated by eq. (7).

For Types A1, B1, and C1 elements (with one end of the P leg free or unrestrained axially) with "short" P legs, L' must be found by a less direct method as follows [1]:

$$L' = [-b + (b^2 - 4ac)^{1/2}]/2a, \text{ in.} \quad (8)$$

where

$$\begin{aligned} a &= 3f/(2AE) \\ b &= \epsilon - fL_2/(AE) + 2f\beta/k \\ c &= -f\beta L_2/k \end{aligned}$$

However, the most highly stressed runs in a buried piping system typically are restrained at both ends, either by a combination of transverse runs or a transverse and an anchor (either real or virtual).

For Types A2, B2, and C2 elements with short P legs, L' is expressed by

$$L' = L_2/2, \text{ in.} \quad (9)$$

For Types A3, B3, C3, and D elements with short P legs, L' is expressed by

$$L' = L_2, \text{ in.} \quad (10)$$

VII-4 COMPUTER MODELING OF BURIED PIPING

VII-4.1 Determination of Stresses

With f , k , and L' or L'' established, the stresses in a buried pipe due to thermal expansion can be determined with a general purpose pipe stress computer program. A buried piping system can be modeled with a typical mainframe or microcomputer pipe stress program by breaking the buried portions into elements of convenient length and then imposing a transverse spring at the center of each element to simulate the passive resistance of the soil. The entire pipe can be divided into spring-restrained elements in this manner; however, the only regions of the pipe that really need to be modeled in this manner are the lengths entering and leaving elbows or tees. The analyst should refer to the program users' manual for guidance in modeling soil springs.

All pipe stress computer programs with buried piping analysis options require that the following factors be calculated or estimated:

- (A) location of the virtual anchor (dimension L' or L'')
- (B) soil spring rate, k_{ij} , which is a function of the modulus of subgrade reaction, k
- (C) influence length, also a function of k

Some programs ignore the friction at the pipe/soil interface; this is conservative for calculating bending stresses on the buried elbows and branch connections, but may be unconservative for calculating anchor reactions.

VII-4.2 Determination of Element Lengths

The element lengths and transverse soil spring rates for each element are calculated by the following procedure.

VII-4.2.1 Establish the element length dL and the number n of elements, as follows:

(A) Set the element length to be equal to between 2 and 3 pipe diameters. For example, dL for a NPS 6 may be set at either 1 ft or 2 ft, whichever is more convenient for the analyst.

(B) Establish the number n of elements by

$$n = (3\pi/4\beta)/dL \quad (11)$$

This gives the number of elements, each being dL inches in length, to which springs are to be applied in the computer model. The number, n , of elements is always rounded up to an integer.

VII-4.2.2 Calculate the lateral spring rate, k_{ij} , to be applied at the center of each element.

$$k_{ij} = kdL, \text{ lb/in.} \quad (12)$$

where

k = the modulus of subgrade reaction calculated from eq. (2).

VII-4.2.3 Calculate the equivalent axial load necessary to simulate friction resistance to expansion. The friction resistance at the pipe/soil interface can be simulated in the computer model by imposing a single force F_f in a direction opposite that of the thermal growth.

$$F_f = fL'/2 \text{ or } fL''/2, \text{ lb} \quad (13)$$

VII-4.2.4 Incorporate the springs and the friction force in the model. The mutually orthogonal springs k_{ij} are applied to the center of each element, perpendicular to the pipe axis. Shorter elements, with proportionally smaller values for the springs on these elements, may be necessary in order to model the soil restraint at elbows and bends. The friction force, F_f , for each expanding leg is imposed at or near the elbow tangent node, opposite to the direction of expansion.

VII-4.3 Determination of Soil Parameters

Soil parameters are difficult to establish accurately due to variations in backfill materials and degree of compaction. Consequently, values for elemental spring constants on buried pipe runs can only be considered as rational approximations. Stiffer springs can result in higher elbow stresses and lower bending stresses at

nearby anchors, while softer springs can have the opposite effects. Backfill is not elastic, testing has shown that soil is stiffest for very small pipe movements, but becomes less stiff as the pipe movements increase. References [4], [7], and [8] discuss soil stiffness and recommend procedures for estimating values for k which are consistent with the type of soil and the amount of pipe movement expected. The analyst should consult the project geotechnical engineer for assistance in resolving any uncertainties in establishing soils parameters, such as the modulus of subgrade reaction, k ; confining pressure, p_c ; and coefficient of friction, μ .

VII-4.4 Pipe With Expansion Joints

An expansion joint must be considered as a relatively free end in calculating stresses on buried elbows and loads on anchors. Since incorporation of expansion joints or flexible couplings introduces a structural discontinuity in the pipe, the effects of the unbalanced pressure load and the axial joint friction or stiffness must be superimposed on the thermal expansion effects in order to determine the maximum pipe stresses and anchor loads.

VII-4.5 Pipe Stresses at Building Penetrations

Stresses at building penetrations can be calculated easily after the reactions due to thermal expansion in the buried piping have been determined. If the penetration is an anchor, then the stress due to the axial force, F_{max} , and the lateral bending moment, M , can be found by

$$S_E = F_{max}/A + M/Z, \text{ psi} \quad (14)$$

If the penetration is not an anchor, but is instead a simple support with a flexible water seal, it is necessary to determine the stiffness affects of the water seal material in order to calculate the stress in the pipe at the penetration. Differential movement due to building or trench settlement can generate high theoretical stresses at piping penetrations to buildings. Calculation of such stresses is beyond the scope of this Appendix.

VII-5 ALLOWABLE STRESS IN BURIED PIPE

Buried piping under axial stress can theoretically fail in one of two ways — either by column buckling (pipe pops out of the ground at mid-span) or local failure by crippling or tensile failure (much more serious than column buckling). Since buried piping stresses are secondary in nature, and since the piping is continuously supported and restrained (see Fig. VII-5), higher total stresses may be permitted as follows:

$$S_C \leq S_A + S_h \quad (15)$$

where S_A and S_h are as defined in para. 102.3.2.

Fig. VII-5 Plan of Example Buried Pipe

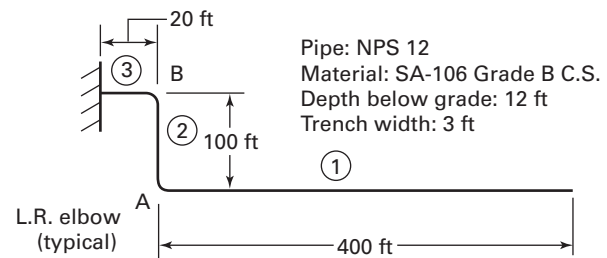

VII-6 EXAMPLE CALCULATIONS

VII-6.1 Assemble the Data

VII-6.1.1 Pipe Data

- (A) diameter, $D = 12.75$ in.
- (B) wall thickness = 0.375 in.
- (C) length of runs
 - (C.1) Run 1: $L_1 = 100$ ft, $L_2 = 400$ ft
 - (C.2) Run 2: $L_1 = 20$ ft, $L_2 = 100$ ft
 - (C.3) Run 3: $L_1 = 100$ ft, $L_2 = 20$ ft
- (D) Young's modulus, $E = 27.9 \times 10^6$ psi
- (E) moment of inertia, $I = 279.3$ in.⁴
- (F) cross section metal area, $A = 14.57$ in.²

VII-6.1.2 Soil Characteristics

- (A) soil density, $w = 130$ lb/ft³
- (B) pipe depth below grade, $H = 12$ ft (144 in.)
- (C) type of backfill: dense sand
- (D) trench width, $B_d = 3$ ft (36 in.)
- (E) coefficient of friction, $\mu = 0.3$ min. to 0.5 max. (estimated)
- (F) horizontal soil stiffness factor, $C_k = 80$

VII-6.1.3 Operating Conditions

- (A) pressure, $P = 100$ psig
- (B) temperature = 140°F
- (C) ambient temperature = 70°F

VII-6.2 Calculate the Intermediate Parameters

VII-6.2.1 Relative Strain at the Pipe/Soil Interface.

Thermal expansion for SA-106 Grade B carbon steel pipe from 70°F to 140°F is 0.0053 in./ft. Therefore,

$$\begin{aligned} \epsilon &= (0.0053 \text{ in./ft}) / (12 \text{ in./ft}) \\ &= 0.000424 \text{ in./in.} \end{aligned}$$

VII-6.2.2 Modulus of Subgrade Reaction, k [8]. Since the expansion is in the horizontal plane, use k_h from eq. (2).

$$k_h = C_k N_h w D$$

$$C_k = 80$$

$$\begin{aligned} N_h &= 0.285 H/D + 4.3 \\ &= 0.285 (12 \text{ ft})(12 \text{ in./ft})/12.75 \text{ in.} + 4.3 \\ &= 7.519 \end{aligned}$$

$$\begin{aligned} w &= (130 \text{ lb/ft}^3)/(1,728 \text{ in.}^3/\text{ft}^3) \\ &= 0.0752 \text{ lb/in.}^3 \end{aligned}$$

$$D = 12.75 \text{ in.}$$

$$k_h = (80)(7.519)(0.0752)(12.75) = 577 \text{ lb/in.}^2$$

VII-6.2.3 Friction Forces Per Unit Length Acting at the Pipe/Soil Interface

$$f = \mu(P_c A_c + W_p)$$

Since the pipe lies more than 3 diameters below grade, the modified Marston equation from [1] is used to determine the confining pressure P_c of soil on the pipe.

$$P_c = w C_D B_d$$

$$\begin{aligned} C_D &= 2.22 \text{ for } H/B_d = 12 \text{ ft}/3 \text{ ft} \\ &= 4 \text{ (see Table VII-3.2.3 for sand)} \end{aligned}$$

$$\begin{aligned} P_c &= (130 \text{ lb/ft}^3)(2.22)(3 \text{ ft})/(144 \text{ in.}^2/\text{ft}^2) \\ &= 6.01 \text{ psi} \end{aligned}$$

$$\begin{aligned} A_c &= D(1 \text{ in.}) = (12.75 \text{ in.})(1 \text{ in.}) \\ &= 40.05 \text{ in.}^2/\text{in. of length} \end{aligned}$$

$$W_p = 8.21 \text{ lb/in. for water-filled carbon steel pipe}$$

Maximum value of friction force per unit length, f_{\max}

$$\begin{aligned} f_{\max} &= 0.5 [(6.01 \text{ psi})(40.05 \text{ in.}^2/\text{in.}) + 8.21 \text{ lb/in.}] \\ &= 124.5 \text{ lb/in.} \end{aligned}$$

Minimum value of friction force per unit length, f_{\min}

$$\begin{aligned} f_{\min} &= 0.3 [(6.01)(40.05) + 8.21] \\ &= 74.7 \text{ lb/in.} \end{aligned}$$

VII-6.2.4 Pipe/Soil System Characteristic, β [2]

$$\begin{aligned} \beta &= [k_h/(4EI)]^{1/4} \\ &= [577 \text{ psi}/4(27.9 \times 10^6 \text{ psi})(279.3 \text{ in.}^4)]^{1/4} \\ &= 0.01166 \text{ in.}^{-1} \end{aligned}$$

VII-6.2.5 Minimum Slippage Length, L_m

$$\begin{aligned} L_m &= \epsilon AE/f_{\min} \\ &= (0.000424 \text{ in./in.})(14.57 \text{ in.}^2)(27.9 \times 10^6 \text{ psi}) \\ &\quad /74.7 \text{ lb/in.} \\ &= 2,307 \text{ in. or } 192 \text{ ft } 4 \text{ in.} \end{aligned}$$

VII-6.2.6 Maximum Axial Force, F_{\max} , Corresponding to L_m

$$\begin{aligned} F_{\max} &= \epsilon AE = (0.000424)(14.57)(27.9 \times 10^6) \\ &= 172,357 \text{ lb} \end{aligned}$$

VII-6.3 Classification of Runs

Classify the pipe runs in accordance with the models given in Table VII-6.3 and calculate the effective slippage length, L' or L'' , for each run.

VII-6.3.1 Run 1 is a Category A1 (elbow on one end, the other end free). Check to see if the transverse leg, L_1 , is long or short.

$$L_1 = 1,200 \text{ in.}$$

$$3\pi/(4)(0.01166 \text{ in.}^{-1}) = 202 \text{ in.}$$

Since $1,200 \text{ in.} > 202 \text{ in.}$, L_1 is long. Check to see if the longitudinal leg, L_2 , is long or short, that is, longer or shorter than $L_m + L''$. Using eq. (7) to calculate L'' ,

$$L'' = \Omega[(1 + 2F_{\max}/f_{\min}\Omega)^{1/2} - 1]$$

$$\begin{aligned} \Omega &= AE\beta/k = (14.57 \text{ in.}^2)(27.9 \times 10^6 \text{ psi}) \\ &\quad \times (0.01166 \text{ in.}^{-1})/577 \text{ psi} = 8,214 \text{ in.} \end{aligned}$$

$$\begin{aligned} L'' &= 8,214\{[1 + 2 \times 172,357/(74.7 \times 8,214)]^{1/2} - 1\} \\ &= 2,051 \text{ in.} \end{aligned}$$

$$L_m + L'' = 2,307 + 2,051 = 4,358 \text{ in.}$$

Since $L_2 = 400 \text{ ft}$ or $4,800 \text{ in.}$, then since $4,800 > 4,358$, the pipe run length L_2 is long, and Run 1 can be fully classified as Category A1 (long transverse, long pipe).

NOTE: If $L_m + L''$ would have exceeded L_2 , then L' would be recalculated using eq. (8), the correct equation for a short pipe.

VII-6.3.2 Run 2 is a Category A2 (elbow on each end). Check to see if the legs L_1 and L_2 are long or short.

Since $L_1 > 3\pi/4\beta$ ($240 \text{ in.} > 202 \text{ in.}$) and $L_2 < 2L''$ [$1,200 \text{ in.} < 2(2,051 \text{ in.})$], then Run 2 can be fully classified as a Category A2 (long transverse, short pipe). Then

$$L' = L_2/2 = (1,200 \text{ in.})/2 = 600 \text{ in.}$$

VII-6.3.3 Run 3 is a Category A3 (anchor on one end, elbow on the other). Check to see if the legs L_1 and L_2 are long or short.

Since $L_1 > 3\pi/4\beta$ ($1,200 \text{ in.} > 202 \text{ in.}$) and $L_2 < L''$ ($240 \text{ in.} < 2,051 \text{ in.}$), then Run 3 can be fully classified as a Category A3 (long transverse, short pipe). Then

$$L' = L_2 = 240 \text{ in.}$$

NOTE: In order to fully qualify a buried piping system, it may also be necessary to include stresses due to weight of overburden (backfill) and vehicular loads [5, 6].

Table VII-6.3 Equations for Calculating Effective Length L' or L''

Element Category	Equations for L' or L''	
	Short P Leg L'	Long P Leg L''
A1, B1, C1	If $L_2 < L_m + L''$, $L' = [-b + (b^2 - 4ac)^{1/2}]/2a$ (8) where $a = 3f/(2AE)$ $b = \epsilon - fl_2/(AE) + 2f\beta/k$ $c = -f\beta L_2/k$	If $L_2 \geq L_m + L''$, $L'' = \Omega[(1 + 2F_{max}/f_{min}\Omega)^{1/2} - 1]$ (7)
A2, B2, C2	If $L_2 < 2L''$, $L' = L_2/2$ (9)	If $L_2 \geq 2L''$, $L'' = \Omega[(1 + 2F_{max}/f_{min}\Omega)^{1/2} - 1]$ (7)
A3, B3, C3	If $L_2 < L''$, $L' = L_2$ (10)	If $L_2 \geq L''$, $L'' = \Omega[(1 + 2F_{max}/f_{min}\Omega)^{1/2} - 1]$ (7)
D	If $L_2 < L_m$, $L' = L_2$ (10)	If $L_2 \geq L_m$, $L'' = L_m = \epsilon AE/f$ (5)

VII-6.4 Computer Modeling

Calculate the soil springs and friction force for use in a computer model of the buried pipe.

VII-6.4.1 Element Length. Set the element length to be ≈ 3 pipe diameters. $dL = 36$ in.

VII-6.4.2 Number of Elements. Only the soil within a length $3\pi/4\beta$ from the elbow will be subject to bearing force from the pipe. For the example system, $3\pi/4\beta = 202$ in. Therefore, the number of elements needed is found by

$$n = (3\pi/4\beta)/dL = 202/36 = 5.61$$

Therefore, use six elements, each 36 in. long.

VII-6.4.3 Spring Rate, k_{ij} . The spring rate to be applied to each element is found by

$$k_{ij} = kdL$$

where k is from eq. (2)

$$k_{ij} = (577 \text{ psi})(36 \text{ in.}) = 20,772 \text{ lb/in.}$$

This is the theoretical spring rate to be imposed at the center of each element and normal to the surface of the pipe, with k_i in the plane of the expansion, and k_j perpendicular to the plane of expansion.

VII-6.4.4 Friction Force, F_f . The friction forces to be applied at the elbow tangent points in Runs 1 and 2 are calculated as follows:

Parallel to Run 1,

$$F_f = fL''/2$$

where

$$f = f_{min} = 74.7 \text{ lb/in.}$$

$$L'' = 2,051 \text{ in.}$$

$$F_f = (74.7 \text{ lb/in.})(2,051 \text{ in.})/2 = 76,605 \text{ lb}$$

Parallel to Run 2,

$$F_f = (74.7 \text{ lb/in.})(600 \text{ in.})/2 = 22,410 \text{ lb}$$

The friction force to be applied at the elbow tangent point in Run 3 is calculated as follows:

Parallel to Run 3,

$$F_f = (74.7 \text{ lb/in.})(240 \text{ in.})/2 = 8,964 \text{ lb}$$

The computer model then appears as is shown in Fig. VII-6.4.4.

Fig. VII-6.4.4 Computer Model of Example Pipe

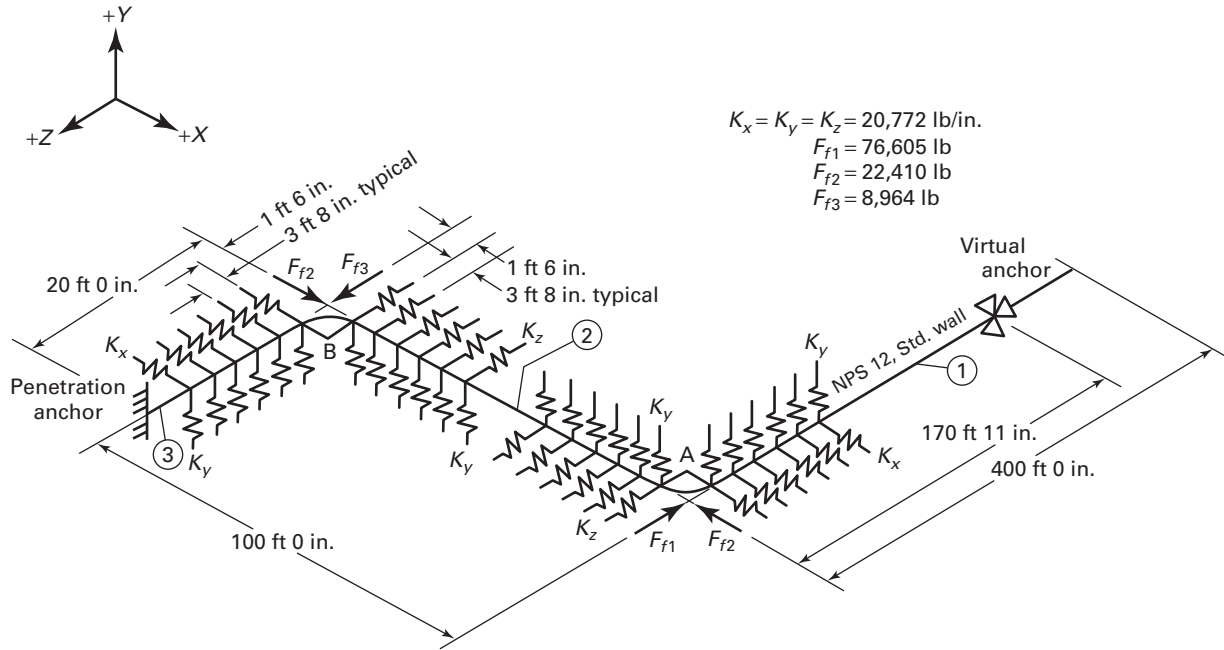

VII-6.5 Results of Analysis

Computer analysis of the model shown in Fig. VII-6.4.4 gives combined stress, S_C , at various locations in the buried pipe as follows:

Location	S_C , psi
Virtual anchor	7,036
Elbow A	26,865
Elbow B	9,818
Penetration anchor	2,200

NOTE: S_C for this example includes longitudinal pressure stress, intensified bending stresses, and direct stresses due to axial loads from friction and soil bearing loads. It does not include weight of backfill or live loads.

The allowable stress as given by eq. (15) is $S_A + S_{hr}$, which for SA-106 Grade B steel pipe is 22,500 psi + 15,000 psi = 37,500 psi. Therefore, since the maximum S_C of 26,865 psi < 37,500 psi, the Code conditions are met.

VII-6.6 Anchor Load Example

If Element 1 were simply a straight pipe anchored at one end with the other end terminating in an expansion joint (see Fig. VII-6.6), the load on the anchor is found as follows:

(A) Calculate the maximum friction force acting along the friction interface.

$$F_f = F_{\max} = \epsilon AE$$

Fig. VII-6.6 Example Plan of Element 1 as a Category D Element

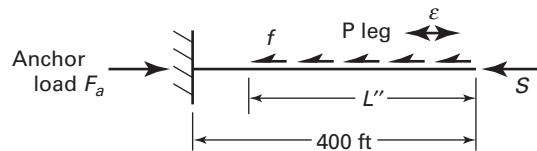

$$F_{\max} = \epsilon AE = (0.000424)(14.57)(27.9 \times 10^6) = 172,357 \text{ lb}$$

(B) Calculate the load, S , at the expansion joint.

$$S = F_j + S_p$$

where

$$F_j = \text{expansion joint friction force} = 9,000 \text{ lb (from vendor data)}$$

$$S_p = \text{pressure force} = PA_s$$

where

$$P = \text{design pressure} = 100 \text{ psig}$$

$$\begin{aligned}
 A_s &= \text{effective cross-sectional area} \\
 &= \pi D^2/4 \\
 &= \pi (12.75^2)/4 \\
 &= 127.6 \text{ in.}^2 \\
 &= (100)(127.6) = 12,760 \text{ lb}
 \end{aligned}$$

$$S = 9,000 + 12,760 = 21,760 \text{ lb}$$

(C) The total axial load, F_a , at the anchor then becomes

$$F_a = 172,357 + 21,760 = 194,117 \text{ lb}$$

If anchor loads must be limited, then the expansion joint should be located closer to the anchor in order to reduce the force due to friction at the pipe/soil interface.

VII-7 REFERENCES

[1] Goodling, E. C., "Buried Piping — An Analysis Procedure Update," ASME Publication PVP — Vol. 77, pp. 225–237, ASME Pressure Vessels and Piping Conference, Portland, June 1983

[2] Hetenyi, K. J., *Beams on Elastic Foundation*, The University of Michigan Press, Ann Arbor, Michigan, 1967

[3] Hunt, R. J., et al., "Seismic Response of Buried Pipes and Structural Components," Report by the Seismic and Materials Committee, ASCE, 1983

[4] Nyman, D. J., et al., *Guidelines for the Seismic Design of Oil and Gas Piping Systems*, Committee on Gas and Liquid Fuel Lifelines of the ASCE Technical Council on Lifeline Earthquake Engineering, 1984

[5] Young, O. C., and Trott, J. J., *Buried Rigid Pipes*, Elsevier Applied Science Publishers, 1984

[6] Moser, A. P., *Buried Pipe Design*, McGraw-Hill, 1990

[7] Audibert, J. M. E., and Nyman, K. J., "Soil Restraint Against Horizontal Motion of Pipes," *Journal of the Geotechnical Engineering Division, ASCE*, Vol. 103, No. GT10, October 1977, pp. 1119–1142

[8] Trautmann, C. H., and O'Rourke, T. D., "Lateral Force-Displacement Response of Buried Pipes," *Journal of Geotechnical Engineering, ASCE*, Vol. 111, No. 9, September 1985, pp. 1077–1092

[9] Leonards, G. A., Editor, *Foundation Engineering*, McGraw-Hill, New York, 1962

[10] Goodling, E. C., "Restrained Underground Piping — Some Practical Aspects of Analysis and Design," Third U.S. Conference on Lifeline Earthquake Engineering, ASCE, Los Angeles, August 22–24, 1991

[11] Antaki, George, and Hart, J. D., et al., "Guide for the Design of Buried Steel Pipe," American Lifelines Alliance under contract with FEMA and ASCE, July 2001.

NONMANDATORY APPENDIX VIII GUIDELINES FOR DETERMINING IF LOW-TEMPERATURE SERVICE REQUIREMENTS APPLY

ASME standard B31T, Standard Toughness Requirements for Piping, establishes a “low-temperature service limit.” If the design minimum temperature is equal to or warmer than the low-temperature service limit, then low-temperature service requirements do not apply. Table VIII-1 summarizes this limit for each material T-number group. Table VIII-2 provides the T-number group for materials listed in ASME B31T.

This Nonmandatory Appendix extracts only part of the requirements of ASME B31T and focuses on services that are exempt from additional requirements. To determine if a material and service have additional

requirements, look up the material in Table VIII-2 and determine the T-number group, and then look up that T-number group (and thickness if applicable) in Table VIII-1 and determine the low-temperature service limit. If the design minimum temperature is equal to or warmer than the low-temperature service limit from Table VIII-1, then ASME B31T would not invoke any additional requirements. If the design minimum temperature is colder than the low-temperature service limit from Table VIII-1, then ASME B31T may invoke additional requirements and further evaluation.

Table VIII-1 Low-Temperature Service Requirements by Material Group

T-Number Group	Nominal Thickness, in.	Low-Temperature Service Limit, °F	Nominal Thickness, mm	Low-Temperature Service Limit, °C
Carbon Steels				
CS -55	...	-20	...	-29
CS -50	...	-20	...	-29
CS -20	...	-20	...	-29
CS -20(A)	...	-20	...	-29
CS 0	...	0	...	-18
CS +20(A)	...	20	...	-7
CS A	≤0.394	20	≤10.0	-7
	≤0.4375	25	≤11.1	-4
	≤0.5	30	≤12.7	-1
	≤0.6	40	≤15.2	4
	≤0.7	50	≤17.7	10
	≤0.85	60	≤21.6	16
	≤1.03	70	≤26.2	21
	≤1.25	80	≤31.1	27
	≤1.5625	90	≤39.7	32
	≤2.0325	100	≤51.6	38
	≤3	110	≤76.2	43
	≤3.6875	115	≤93.7	46
	>3.6875	120	>93.7	49
CS B	≤0.394	-20	≤10.0	-29
	≤0.47	-10	≤11.9	-23
	≤0.57	0	≤14.5	-18
	≤0.68	10	≤17.3	-12
	≤0.83	20	≤21.1	-7
	≤0.98	30	≤24.9	-1
	≤1.19	40	≤30.2	4
	≤1.47	50	≤37.3	10
	≤1.85	60	≤47.0	16
	≤2.4385	70	≤61.9	21
	≤3.25	80	≤82.6	27
	≤4.00	90	≤101.6	32
	>4.00	120	>101.6	49
CS C	≤0.65	-20	≤16.5	-29
	≤0.85	-10	≤21.6	-23
	≤1.08	0	≤27.4	-18
	≤1.38	10	≤35.1	-12
	≤1.75	20	≤44.5	-7
	≤2.25	30	≤57.2	-1
	≤2.94	40	≤74.7	4
	≤3.75	50	≤95.3	10
	≤4.00	52	≤101.6	11
	>4.00	120	>101.6	49
CS D	≤1.3	-20	≤33.0	-29
	≤1.6875	-10	≤42.9	-23
	≤2.25	0	≤57.2	-18
	≤2.9375	10	≤74.6	-12
	≤3.75	20	≤95.3	-7
	≤4.00	23	≤101.6	-5
	>4.00	120	>101.6	49

Table VIII-1 Low-Temperature Service Requirements by Material Group (Cont'd)

T-Number Group	Nominal Thickness, in.	Low-Temperature Service Limit, °F	Nominal Thickness, mm	Low-Temperature Service Limit, °C
Low Alloy Steels				
LA -320	...	-20	...	-29
LA -275	...	-20	...	-29
LA -150	...	-20	...	-29
LA -100	...	-20	...	-29
LA -75	...	-20	...	-29
LA -55	...	-20	...	-29
LA -40	...	-20	...	-29
LA -20	...	-20	...	-29
LA 0	...	0	...	-18
LA +20	...	20	...	-7
Stainless Steels				
SS -425	...	-20	...	-29
SS -325	...	-20	...	-29
SS -60	...	-20	...	-29
SS -20	...	-20	...	-29
Nickel Alloys				
NI -325	...	-325	...	-198
Cast Irons				
CI -20	...	-20	...	-29
CI -20(A)	...	-20	...	-29
Copper Alloys				
CU -452	...	-452	...	-269
CU -325	...	-325	...	-198
Aluminum Alloys				
AL -452	...	-452	...	-269
Titanium and Titanium Alloys				
TI -75	...	-75	...	-59
Zirconium and Zirconium Alloys				
ZI -75	...	-75	...	-59

Table VIII-2 Material Groupings by Material Specification

Spec. No.	Type/Grade/Class/ Condition/Temper/UNS No.	T-Number Group	Material Type	Product Form	Notes
A36	...	CS A	Carbon steels	PL	...
A47	Grade 32510	CI -20(A)	Cast irons	C	...
A48	Grade 20, 25, 30, 35, 40, 45, 50, 55, 60	CI -20	Cast irons	C	...
A53	Grade A (Type F)	CS +20(A)	Carbon steels	P	...
	Grade A (except Type F), B	CS B	Carbon steels	P	...
A105	...	CS -20	Carbon steels	FI & FO	...
A106	Grade A, B, C	CS B	Carbon steels	P	...
A126	Class A, B, C	CI -20	Cast irons	C	...
A134	Grade A283 Gr. A, A283 Gr. B	CS B	Carbon steels	P	...
	Grade A283 Gr. C, D	CS A	Carbon steels	P	...
	Grade A285 Gr. A, A285 Gr. B	CS B	Carbon steels	P	...
	Grade A285 Gr. C	CS A	Carbon steels	P	...
	Grade A36	CS A	Carbon steels	P	...
	Grade A570 Gr. 30, 33, 36, 40, 45, 50	CS A	Carbon steels	P	...
A135	Grade A, B	CS B	Carbon steels	P	...
A139	Grade A, B, C, D, E	CS A	Carbon steels	P	...
A167	Type 347, 348	SS -325	Stainless steels	PL	(1)
	Type 347, 348	SS -20	Stainless steels	PL	(2)
	Type 302B, 308	SS -325	Stainless steels	PL	(3)
	Type 302B, 308	SS -20	Stainless steels	PL	(4)
	Type 309, 310	SS -325	Stainless steels	PL	(1), (3), (5)
	Type 309, 310	SS -20	Stainless steels	PL	(2) or (4), (5)
A178	Grade A, C	CS -20	Carbon steels	T	...
A179	...	CS -20	Carbon steels	T	...
A181	Class 60, 70	CS A	Carbon steels	FI & FO	...
A182	Grade F1, F2, F5, F5a, F9, F11, F12, F21, F22, F91	LA -20	Low alloy steels	FI & FO	...
	Grade F10	SS -325	Stainless steels	FI & FO	(3)
	Grade F10	SS -20	Stainless steels	FI & FO	(4)
	Grade F304, F304L, F316, F316L	SS -425	Stainless steels	FI & FO	...
	Grade F304H, F316H, F317L, F321, F321H, F347, F347H, F348, F348H	SS -325	Stainless steels	FI & FO	...
	Grade F310	SS -325	Stainless steels	FI & FO	(3), (5)
	Grade F310	SS -20	Stainless steels	FI & FO	(4), (5)
	Grade F6a	SS -20	Stainless steels	FI & FO	(5)
	Grade F60 (S32205)	SS -20	Stainless steels	FI & FO	(5)
	Grade S32760	SS -60	Stainless steels	FI & FO	...
A192	...	CS -20	Carbon steels	T	...
A193	Grade B5 ≤4 in., B16 ≤4 in.	LA -20	Low alloy steels	B	...
	Grade B6	SS -20	Stainless steels	B	...
	Grade B7 ≤2½ in.	LA -55	Low alloy steels	B	...
	Grade B7 >2½ in., ≤4 in.	LA -40	Low alloy steels	B	...
	Grade B7M ≤4 in.	LA -55	Low alloy steels	B	...
	Grade B8 Cl. 2, B8C Cl. 1 and Cl. 2, B8M, B8T	SS -325	Stainless steels	B	(6)
	Grade 1	CS -20	Carbon steels	N	...
Grade 3	LA -20	Low alloy steels	N	...	
Grade 6	SS -20	Stainless steels	N	...	
Grade 2, 2H, 2HM	CS -55	Carbon steels	N	...	
Grade 4, 7, 7M	LA -150	Low alloy steels	N	...	
Grade 8, 8CA, 8FA, 8MA, 8TA	SS -325	Stainless steels	N	...	
Grade 8A	SS -425	Stainless steels	N	...	
A197	...	CI -20(A)	Cast Irons	C	...

Table VIII-2 Material Groupings by Material Specification (Cont'd)

Spec. No.	Type/Grade/Class/ Condition/Temper/UNS No.	T-Number Group	Material Type	Product Form	Notes
A202	Grade A, B	LA -20	Low alloy steels	PL	...
A203	Grade A, B, D, E	LA -20	Low alloy steels	PL	...
A204	Grade A, B, C	LA -20	Low alloy steels	PL	...
A210	Grade A-1	CS -20	Carbon steels	T	...
A214	...	CS -20	Carbon steels	T	...
A216	Grade WCA, WCB, WCC	CS -20	Carbon steels	C	...
A217	Grade C5, C12, WC1, WC4, WC5, WC6, WC9 Grade CA-15	LA -20 SS -20	Low alloy steels Stainless steels	C C	... (5)
A226	...	CS -20	Carbon steels	T	...
A234	Grade WP1, WP5, WP9, WP11, WP12, WP22, WP91 Grade WPB, WPC	LA -20 CS B	Low alloy steels Carbon steels	FI FI
A240	Type 305	SS -325	Stainless steels	PL	(1), (3)
	Type 305	SS -20	Stainless steels	PL	(2) or (4)
	Type 302, 317, 317L, 321, 321H, 347, 348	SS -325	Stainless steels	PL	(1)
	Type 302, 317, 317L, 321H, 348	SS -20	Stainless steels	PL	(2)
	Type 304, 304L, 316, 316L	SS -425	Stainless steels	PL	(1)
	Type 304, 304L, 316, 316L, 321, 347	SS -20	Stainless steels	PL	(2)
	Type 309S, 310S	SS -325	Stainless steels	PL	(1), (5)
	Type 309S, 310S	SS -20	Stainless steels	PL	(2), (5)
	Type 405, 410, 410S, 420, 429, X8M	SS -20	Stainless steels	PL	(5)
	UNS S32205	SS -20	Stainless steels	PL	(5)
	UNS S32760	SS -60	Stainless steels	PL	...
A268	Grade TP405, TP409, TP410, TP430, TP430Ti, TP433, TP436	SS -20	Stainless steels	T	(5)
A269	Grade TP304, TP304L, TP316, TP316L	SS -425	Stainless steels	P	(1)
	Grade TP304, TP304L, TP316, TP316L	SS -20	Stainless steels	P	(2)
A278	Class 20, 25, 30, 35, 40, 45, 50, 60	CI -20	Cast irons	C	...
A283	Grade A, B, C, D	CS A	Carbon steels	PL	...
A285	Grade A, B	CS B	Carbon steels	PL	...
	Grade C	CS A	Carbon steels	PL	...
A299	...	CS A	Carbon steels	PL	...
A302	Grade A, B, C, D	LA -20	Low alloy steels	PL	...
A307	Grade B	CS -20	Carbon steels	B	...
A312	Grade TP304, TP304L, TP316, TP316L	SS -425	Stainless steels	P	(1)
	Grade TP304, TP304L, TP316, TP316L	SS -20	Stainless steels	P	(2)
	Grade TP304H, TP316H, TP321H, TP347H, TP348H	SS -325	Stainless steels	P	...
	Grade TP309, TP310	SS -325	Stainless steels	P	(1), (3), (5)
	Grade TP309, TP310	SS -20	Stainless steels	P	(2) or (4), (5)
	Grade TP317, TP317L, TP321, TP347, TP348	SS -325	Stainless steels	P	(1)
	Grade TP317, TP317L, TP321, TP347, TP348	SS -20	Stainless steels	P	(2)
A320	Grade B8 Cl. 1	SS -425	Stainless steels	B	...
	Grade B8C Cl. 1, B8 Cl. 2, B8C Cl. 2, B8F, B8M, B8T	SS -325	Stainless steels	N	...
	Grade L7, L43	LA -150	Low alloy steels	B	(7)
	Grade L7A, L7B, L7C	LA -150	Low alloy steels	B	(7)
	Grade L7M	LA -100	Low alloy steels	B	(7)
A325	...	CS -20	Carbon steels	B	...
A333	Grade 8	LA -320	Low alloy steels	P	(7)
	Grade 1, 6	CS -50	Carbon steels	P	(7)
	Grade 3, 4	LA -150	Low alloy steels	P	(7)
	Grade 7, 9	LA -100	Low alloy steels	P	(7)

Table VIII-2 Material Groupings by Material Specification (Cont'd)

Spec. No.	Type/Grade/Class/ Condition/Temper/UNS No.	T-Number Group	Material Type	Product Form	Notes
A334	Grade 3	LA -150	Low alloy steels	T	(7)
	Grade 8	LA -320	Low alloy steels	T	(7)
	Grade 1, 6	CS -50	Carbon steels	T	(7)
	Grade 7, 9	LA -100	Low alloy steels	T	(7)
A335	Grade P1, P2, P5, P5b, P5c, P9, P11, P12, P15, P21, P22, P91	LA -20	Low alloy steels	P	...
A350	Grade LF1	CS -20	Carbon steels	FI & FO	(7)
	Grade LF2 Cl. 1	CS -50	Carbon steels	FI & FO	(7)
	Grade LF2 Cl. 2	CS 0	Carbon steels	FI & FO	(7)
	Grade LF3	LA -150	Low alloy steels	FI & FO	(7)
A351	Grade CE20N, CH10, CH20, CK20, HK30, HK40	SS -20	Stainless steels	C	(5)
	Grade CE8MN, CD3M-W-Cu-N, CF3, CF3A, CF3M, CF8, CF8A, CF8C, CF8M, CH8, CN7M, CF10MC, HT30	SS -20	Stainless steels	C	...
A352	Grade LC1	LA -75	Low alloy steels	C	(7)
	Grade LC2	LA -100	Low alloy steels	C	(7)
	Grade LC3	LA -150	Low alloy steels	C	(7)
	Grade LCB	CS -50	Carbon steels	C	(7)
A353	...	LA -320	Low alloy steels	PL	(7)
A354	Grade BC	LA 0	Low alloy steels	B	...
	Grade BD	LA +20	Low alloy steels	B	...
A358	Grade 304, 304L, 316, 316L	SS -425	Stainless steels	P	(1)
	Grade 304, 304L, 316, 316L	SS -20	Stainless steels	P	(2)
	Grade 309S, 310S	SS -325	Stainless steels	P	(1), (5)
	Grade 309S, 310S	SS -20	Stainless steels	P	(2), (5)
	Grade 321, 347, 348, S34565	SS -325	Stainless steels	P	(1)
	Grade 321, 347, 348, S34565	SS -20	Stainless steels	P	(2)
A369	Grade FP1, FP2, FP3b, FP5, FP9, FP11, FP12, FP21, FP22	LA -20	Low alloy steels	P	...
	Grade FPA	CS B	Carbon steels	P	...
	Grade FPB	CS -20	Carbon steels	P	...
A376	Grade 16-8-2H	SS -325	Stainless steels	P	(1), (5)
	Grade 16-8-2H	SS -20	Stainless steels	P	(2), (5)
	Grade TP304, TP316	SS -425	Stainless steels	P	(1)
	Grade TP304, TP316, TP321, TP347, TP348	SS -20	Stainless steels	P	(2)
	Grade TP304H, TP316H, TP321, TP321H, TP347, TP347H, TP348	SS -325	Stainless steels	P	(1)
	Grade TP304H, TP316H, TP321H, TP347H	SS -20	Stainless steels	P	(2)
A381	Class Y35, Y42, Y46, Y48, Y50, Y52, Y56, Y60	CS A	Carbon steels	P	...
A387	Grade 2, 5, 9, 11, 12, 21, 22, 91	LA -20	Low alloy steels	PL	...
A395	...	CI -20(A)	Cast irons	C	...
A403	Grade WP304, WP304L, WP316, WP316L	SS -425	Stainless steels	FI	...
	Grade WP304H, WP316H, WP317, WP317L, WP321, WP321H, WP347, WP347H, WP348	SS -325	Stainless steels	FI	...
	Grade WP309, WP310	SS -325	Stainless steels	FI	(3), (5)
	Grade WP309, WP310	SS -20	Stainless steels	FI	(4), (5)
A409	Grade TP304, TP316	SS -425	Stainless steels	P	(1)
	Grade TP304, TP316	SS -20	Stainless steels	P	(2)
	Grade TP309, TP310	SS -20	Stainless steels	P	(2) or (4), (5)
	Grade TP309, TP310	SS -325	Stainless steels	P	(1), (3), (5)
	Grade TP317, TP321, TP347, TP348	SS -325	Stainless steels	P	(1)
	Grade TP317, TP321, TP347, TP348	SS -20	Stainless steels	P	(2)

Table VIII-2 Material Groupings by Material Specification (Cont'd)

Spec. No.	Type/Grade/Class/ Condition/Temper/UNS No.	T-Number Group	Material Type	Product Form	Notes
A414	Grade A	CS B	Carbon steels	PL	...
	Grade B, C, D, E, F, G	CS A	Carbon steels	PL	...
A420	Grade WPL3	LA -150	Low alloy steels	FI	(7)
	Grade WPL6	CS -50	Carbon steels	FI	(7)
	Grade WPL8	LA -320	Low alloy steels	FI	(7)
A426	Grade CP1, CP2, CP5, CP5b, CP9, CP11, CP12, CP15, CP21, CP22	LA -20	Low alloy steels	P	...
	Grade CPCA-15	SS -20	Stainless steels	P	(5)
A437	Grade B4B, B4C	SS -20	Stainless steels	B	...
A451	Grade CPE20N, CPH8, CPH10, CPH20, CPK20	SS -20	Stainless steels	P	(5)
	Grade CPF8, CPF8C, CPF8M, CPF10MC	SS -20	Stainless steels	P	...
A453	Grade 651 Cl. A and Cl. B	SS -20	Stainless steels	B	...
A479	Type 304H, 316, 316H	SS -325	Stainless steels	PL	...
	Type 304, 304L, 316L	SS -425	Stainless steels	PL	...
A487	Grade CA6NM	SS -20	Stainless steels	C	(5)
A515	Grade 60	CS B	Carbon steels	PL	...
	Grade 65, 70	CS A	Carbon steels	PL	...
A516	Grade 55, 60 — not normalized	CS C	Carbon steels	PL	(8)
	Grade 55, 60, 65, 70 — normalized	CS D	Carbon steels	PL	(8)
	Grade 65, 70 — not normalized	CS B	Carbon steels	PL	(8)
A524	Grade I, II	CS -20	Carbon steels	P	...
A536	Grade 65-45-12, 60-40-18	CI -20	Cast irons	C	...
A537	Class 1	CS D	Carbon steels	PL	...
A553	Type 2	LA -275	Low alloy steels	PL	(7)
	Type 1	LA -320	Low alloy steels	PL	(7)
A563	Grade A	CS -20(A)	Carbon steels	N	...
A570	Grade 30, 36, 40, 45, 50	CS A	Carbon steels	PL	...
A571	Type D-2M, Cl. 1	CI -20	Cast irons	C	(9)
A587	...	CS -20	Carbon steels	P	...
A645	...	LA -275	Low alloy steels	PL	(7)
A671	Grade CA55 (A285 Gr. C), CB70 (A515 Gr. 70), CK75 (A299), CMS75 (A299)	CS A	Carbon steels	P	...
	Grade CB60 (A515 Gr. 60), CC65 (A516 Gr. 65), CC70 (A516 Gr. 70)	CS B	Carbon steels	P	...
	Grade CC60 (A516 Gr. 60)	CS C	Carbon steels	P	...
	Grade CD70 (A537 Cl. 1)	CS D	Carbon steels	P	...
	Grade CF70, CF71	LA -20	Low alloy steels	P	...
A672	Grade A45 (A285 Gr. A), A50 (A285 Gr. B), B60 (A515 Gr. 60), C65 (A516 Gr. 65), C70 (A516 Gr. 70)	CS B	Carbon steels	P	...
	Grade A55 (A285 Gr. C), B65 (A515 Gr. 65), B70 (A515 Gr. 70), N75 (A299)	CS A	Carbon steels	P	...
	Grade C55 (A516 Gr. 55), C60 (A516 Gr. 60)	CS C	Carbon steels	P	...
	Grade D70 (A537 Cl. 1)	CS D	Carbon steels	P	...
	Grade L65, L70, L75	LA -20	Low alloy steels	P	...
A675	Grade 45, 50, 55, 60, 65, 70, 80	CS -20	Carbon steels	B	(10)
A691	Grade 1/2Cr, 1Cr, 1 1/4Cr, 2 1/4Cr, 3Cr, 5Cr, 9Cr, CM-65, CM-70, CM-75, P91	LA -20	Low alloy steels	P	...
	Grade CMS-75 (A299)	CS A	Carbon steels	P	...
	Grade CMSH-70 (A537 Cl. 1)	CS D	Carbon steels	P	...

Table VIII-2 Material Groupings by Material Specification (Cont'd)

Spec. No.	Type/Grade/Class/ Condition/Temper/UNS No.	T-Number Group	Material Type	Product Form	Notes
A789	UNS S31803, S32304, S32750, S32760	SS -60	Stainless steels	T	...
	UNS S32205	SS -20	Stainless steels	P	(5)
	UNS S32900	SS -20	Stainless steels	T	...
A790	UNS S31803, S32304, S32750, S32760	SS -60	Stainless steels	P	...
	UNS S32205	SS -20	Stainless steels	P	(5)
	UNS S32900	SS -20	Stainless steels	P	...
A815	UNS S32205	SS -20	Stainless steels	FI & FO	(5)
	UNS S32760	SS -60	Stainless steels	FI & FO	...
API 5L	Grade A, A25 (smls. & ERW), B	CS B	Carbon steels	P	...
	Grade A25 (butt weld)	CS -20(A)	Carbon steels	P	...
	Grade X42, X46, X52, X56, X60, X65, X70, X80	CS A	Carbon steels	P	...
	Grade X42, X46, X52, X56, X60, X65, X70, X80	CS B	Carbon steels	P	(11)
B21	UNS C46400, C48200, C48500	CU -325	Copper alloys	B	(10)
B42	UNS C10200, C12000, C12200	CU -452	Copper alloys	P	...
B43	UNS C23000	CU -452	Copper alloys	P	...
B61	UNS C92200	CU -325	Copper alloys	C	...
B62	UNS C83600	CU -325	Copper alloys	C	...
B68	UNS C12200	CU -452	Copper alloys	T	...
B75	UNS C10200, C12000, C12200	CU -452	Copper alloys	T	...
B88	UNS C12200	CU -452	Copper alloys	T	...
B96	UNS C65500	CU -452	Copper alloys	PL	...
B98	UNS C65100, C65500, C66100	CU -325	Copper alloys	B	(10)
B148	UNS C95200, C95300, C95500	CU -452	Copper alloys	C	...
	UNS C95400, C95600	CU -325	Copper alloys	C	...
B150	UNS C61400, C63000, C64200	CU -325	Copper alloys	B	(10)
B152	UNS C10200, C10400, C10500, C10700, C12200, C12300	CU -452	Copper alloys	PL	...
B169	UNS C61400	CU -452	Copper alloys	PL	...
B171	UNS C70600, C71500	CU -452	Copper alloys	PL	...
B187	UNS C10200, C11000, C12000, C12200	CU -325	Copper alloys	B	(10)
B280	UNS C12200	CU -452	Copper alloys	T	...
B283	UNS C11000, C46400, C65500	CU -452	Copper alloys	FO	...
	UNS C37700, C48500, C67500	CU -325	Copper alloys	FO	...
B466	UNS C70600, C71000	CU -452	Copper alloys	P & T	...
B467	UNS C70600, C71500	CU -452	Copper alloys	P	...
B493	Grade R60702, R60705	ZI -75	Zirconium	FO	...
B523	Grade R60702, R60705	ZI -75	Zirconium	T	...
B550	Grade R60702, R60705	ZI -75	Zirconium	PL	...
B551	Grade R60702, R60705	ZI -75	Zirconium	PL	...
B584	UNS C86200, C86300, C86400, C86500, C86700, C90300, C90500, C92200, C92300, C97300, C97600, C97800	CU -325	Copper alloys	C	...
B658	Grade R60702, R60705	ZI -75	Zirconium	P	...
Various	Various	NI -325	Nickel alloys	Various	...
Various	Various	AL -452	Aluminum
Various	Various	TI -75	Titanium

Table VIII-2 Material Groupings by Material Specification (Cont'd)

GENERAL NOTE: The product form abbreviations are

B = bolts	N = nuts
C = castings	P = pipe
Fl = fittings	PL = plates, sheets, and bars
FO = forgings	T = tube

NOTES:

- (1) Solution heat treated after forming.
- (2) Not solution heat treated after forming.
- (3) Carbon content $\leq 0.10\%$.
- (4) Carbon content $> 0.10\%$.
- (5) This material may have low impact properties at room temperature after being exposed to high service temperatures.
- (6) Strain hardened varieties of this carbide solution treated bolting material can also be used at the low temperatures indicated.
- (7) Material specification requires impact testing.
- (8) These materials' group depends on whether they are normalized or not.
- (9) Min. temperature -320°F (-195°C) with impact testing.
- (10) Bar specification used for making bolting material.
- (11) T-Number Group CS-B may be used only when normalized or quenched and tempered.

INDEX

- acceptable materials
 - standards and specifications, 123.1, Table 126.1, Appendix F
- access holes, 114.2.2
- air and hydraulic distribution systems, 100.1.2(E)
- alignment, 127.3(C)
- allowable stresses, shear, 102.3.1(B)
- allowable stress values, 102.3.1(A), Appendix A
- aluminum pipe, 124.7(A)
- anchors, 119.7.1(A.3), 120.2.3
- anchors and guides, 120.2.3, 121.7.1
- annealing, definition, 100.2
- ANSI standards, Table 126.1, Appendix F
- API standards, Table 126.1, Appendix F
- arc welding, definition, 100.2
- ASME codes and standards, Table 126.1, Appendix F
- ASME SA and SB specifications, 123.1
- assembly, 135
- assembly, definition, 100.2
- ASTM specifications, Table 126.1, Appendix F
- ASTM standard test methods, Table 126.1, Appendix F
- attachments
 - design rules, 104.3.4
 - structural, 121.8
 - structural, definition, 100.2
- attachment welds, 127.4.9
- automatic welding, definition, 100.2
- AWS filler metal specifications, Table 126.1, Appendix F
- AWWA standards, Table 126.1, Appendix F

- backing ring, definition, 100.2
- backing rings, 111.2.2, 127.2.2
 - acceptable types, 127.2.2(A.1)
 - ferrous, 127.2.2(A)
 - longitudinal welded joints, 127.2.2(A.3)
 - nonferrous and nonmetallic, 127.2.2(B)
- ball joints, 101.7.2, 119.5.1
- base metal, definition, 100.2
- bell end joints, 116
- bending, 102.4.5, 129
 - heat treatment, 129.3
- bends, 119.5
- bend thinning allowance, Table 102.4.5
- blanks, pipe, 108.2
- blowdown valves for instruments, 122.3.2(B.2)
- blowoff and blowdown piping, 122.1.7, 122.2
- blowoff valves, 122.1.7(C)
- boiler drains, 122.1.5
- boiler external piping, 100.1.2(A), 122.1
 - authorized installation, 127.5.3(C)
 - carbon or alloy steel, 124.2(C)
 - cast iron, 124.4
 - ductile (nodular) iron, 124.6
 - malleable iron, 124.5
 - materials acceptable, 123.1, Table 126.1, Appendix F
 - miscellaneous systems, 122.1.6
 - specifications Table, 126.1, Appendix F
 - standards Table, 126.1, Appendix F
 - steel, carbon and alloy, 124.2
- bolting, metric, 108.6
- bolting, piping flange, 108.5, Table 112
- bolting procedure, 135.3
- bolts, 108.5
 - engagement, 135.3.4
- bolt studs, 108.5, Table 112
- bonnet joint, valve, 107.5
- branch connections, 127.4.8
 - definition, 100.2
 - design rules, 104.3.1
 - extrusions, 104.3.1(G)
 - multiple openings, 104.3.1(D.2.5)
 - subject to external pressure, 104.3.1(E)
 - weld design, 127.4.8
- brazed joints, 117
- braze welding definition, 100.2
- brazing, 128
 - alloy, 117.1
 - definition, 100.2
 - filler metal, 128.2.1
 - flux, 128.2.2
 - heating, 128.4.2
 - material, 128.2
 - preparation, 128.3
 - procedure, 128.4
 - qualification, 128.5
 - records, 128.6
- butt joint, definition, 100.2
- butt welds
 - alignment, 111.2.1, 127.3(C)
 - end preparation dimensions, 127.3(A.2)
- bypasses, valve, 107.6
- bypass valves, 122.5.2 and 122.5.3

- capacitor discharge welding (CDW), definition, 100.2
- carbon limitations
 - welded construction, 124.2(C)
- cast iron limitations, 124.4
- cast iron to steel flanged joints, 135.3.3

- central and district heating systems, 100.1.1, 100.1.2(B)
centrifugally cast pipe, definition, 100.2
cladding and lining materials, 124.8
cleaning, welding, 127.3(B)
cleaning fluid load, 101.6.3
cold bending, 129.3.1, 129.3.3(B)
cold spring, 119.2
columns, water, 122.1.6(C)
compression joints, 115
concavity, girth butt welds, 127.4.2(C.5)
condensing reservoirs, 122.3.2(C)
connection, equipment, definition, 100.2
connection branch, definition, 100.2
constant supports, 121.7.4
consumable inserts, 127.2.3
contraction, 101.7
control piping, 122.3.3
cooling effect, 101.4.1
copper pipe, 124.7(A)
corrosion allowance, 102.4.1
corrosion control, Appendix IV
corrosive liquids and gases, 122.9
corrugated pipe, 119.5
creep range, 119.3
curved pipe, 104.2
- dead load, 101.6.2
defect, definition, 100.2
definitions, 100.2
design
 cast iron, 124.4
 criteria, 102
 ductile (nodular) iron, 124.6
 malleable iron, 124.5
 nonferrous metals, 124.7
 nonmetallic pipe, 124.8
 steel, 124.2
design conditions, 101
design pressure, 104.1.2(A)
design temperature, 101.3.2
desuperheaters, 122.4
deterioration of materials, 124.10
discontinuity, definition, 100.2
dissimilar welds — backing, 127.2.2(A.2)
district heating systems, 100.1.1, 122.14
double submerged arc welded pipe, definition, 100.2
drain piping, 122.1.5(A)
drains, miniature boilers, valves, 122.1.5(C)
drains, valve, 122.1.5(B)
drip lines, 122.11.1
ductile iron bell end piping, 135.7
ductile (nodular) iron limitations, 124.6
ductile iron pipe thickness, 104.1.2(B)
ductility, 119.3
dynamic effects, 101.5
- earthquake loadings, 101.5.3
elbows, 104.2.2
electric flash welded pipe, definition, 100.2
electric fusion welded pipe, definition, 100.2
electric resistance welded pipe, definition, 100.2
end preparation, welding, 127.3(A)
ends, valve, 107.3
engineering design, definition, 100.2
entrapped pressure, valve, 107.1(C)
equipment connection, definition, 100.2
equivalent full temperature cycle, 102.3.2(C)
erection, definition, 100.2
erosion allowance, 102.4.1
erosion/corrosion, Appendix IV
examination, 136.3
 general, 136.3.1
 liquid penetrant, 136.4.4
 acceptance standards, 136.4.4(B)
 evaluation of indications, 136.4.4(A)
 magnetic particle, 136.4.3
 acceptance standards, 136.4.3(B)
 evaluation of indications, 136.4.3(A)
 mandatory minimum requirements, Table 136.4
 radiography, 136.4.5
 acceptance standards, 136.4.5(A)
 requirements, 136.4
 visual, 136.4.2
 acceptance standards, 136.4.2(A)
exhaust piping, 122.12
expanded joints, 113
expansion, 119
 joints, 101.7.2
 properties, 119.6
 stress, 102.3.2(C)
external design pressure, 101.2.4
extruded pipe, definition, 100.2
extrusion, 129.2
- fabrication, definition, 100.2
face of weld, definition, 100.2
facings, flange, 108.3, 108.5.2, Table 112
federal specifications, Table 126.1, Appendix F
feedwater piping, 122.1.3
feedwater valves, 122.1.7(B)
filler metal, 127.2.1
 brazing, 128.2.1
 definition, 100.2
fillet weld, definition, 100.2
fillet welds, 111.4
 welding, 127.4.4
fittings, 115
fittings and joints for instrument, control, and sampling piping, 122.3.6
fixtures, 121.2
flammable and toxic gases and liquids, 122.8
flammable fluids, 117.3(A)

- flange, material combinations, Table 112
- flange bolting, pipe, 108.5, Table 112
- flanged elbows, 104.2.2
- flanged joints, 112, 135.2.1
- flange facings, 108.3, 108.5.2, Table 112
- flange gaskets, 108.4, 108.5.2, Table 112
- flanges, pipe, 108.1
- flared joints, 115
- flareless joints, 115
- flattening, 104.2.1(C)
- flaw, definition, 100.2
- flexibility, 119
 - factors, 119.7.3, Appendix D
- flexible hose
 - metallic, 101.7.2, 106.4, 119.5, 121.7.1(C)
 - nonmetallic, 105.3(D)
- fluid expansion effects, 101.4.2
- flux, brazing, 128.2.2
- forged and bored pipe, definition, 100.2
- formed components, heat treatment, 129.3
- forming, 129.2
- full fillet weld, definition, 100.2
- furnace butt welded pipe, definition, 100.2
- fusion, definition, 100.2

- gage cocks, 122.1.6(C)
- gage glass, 122.1.6
 - connections, 122.1.6(A)
- galvanic corrosion, 124.7(B)
- gas blow, definition, 100.2
- gaskets, pipe flange, 108.4, 108.5.2, Table 112
- gas purge, definition, 100.2
- gas welding, definition, 100.2
- geothermal systems, 100.1.2(B)
- girth butt welds, 127.4.2
- graphitization, 124.2(A) and (B)
- grinding, girth butt welds, 127.4.2(C.4)
- groove weld, definition, 100.2

- hanger adjustments, 121.4
- hangers and supports, definitions, 100.2
- hanger spacing, 121.5
- heat affected zone, definition, 100.2
- heat exchanger piping, design temperature, 101.3.2(B)
- heating, brazing, 128.2.3
- heat treatment
 - austenitic stainless steel bends and formed components, 129.3.4
 - bends, 129.3
 - definition, 100.2
 - formed components, 129.3
 - heating and cooling requirements, 132.6, 132.7
 - welds, 127.4.10, 131, 132, Table 132

- impact, 101.5.1
- imperfection, definition, 100.2

- indication, definition, 100.2
- inert gas metal arc welding
 - definition, 100.2
- inquiries, Appendix H
- inspection
 - instrument, control, and sampling piping, 122.3.9(A)
 - requirements, 136.2
- inspection and examination, 136
 - general, 136.1.1
 - verification of compliance, 136.1.2
- inspectors
 - qualification of owner's, 136.1.4
 - rights of, 136.1.3
- instrument
 - piping, 122.3
 - valves, 122.3.2(B)
- integral type, 121.8.2
- internal design pressure, definition, 101.2.2
- internal pressure design, 104.1.2
- interruption of welding, 131.6
- intersections, 104.3
 - branch connections, 104.3.1
 - design rules, 104.3

- joint, butt, definition, 100.2
- joint, mechanical, definition, 100.2
- joint clearance, brazing, 128.3.2
- joint design, definition, 100.2
- joint efficiency, 102.3.2(C)
- joint penetration, definition, 100.2
- joints, valve bonnet, 107.5

- lapping, 129.2
- level indicators, 122.1.6
- limitations on materials, 123.2
- live load, 101.6.1
- loads and supporting structures, 121.4
- local overstrain, 119.3
- local postweld heat treatment, 132.7
- longitudinal welds, 127.4.3
- loops, 119.5
- low energy capacitor discharge welding, 127.4.9(A)

- main line shutoff valves, 122.3.2(A.1)
- malleable iron limitations, 124.5
- manual welding, definition, 100.2
- marking
 - materials, products, 123.1(E)
 - valve, 107.2
- materials
 - general requirements, 123
 - limitations, 124
 - miscellaneous parts, 125
 - bolting, 125.4
 - gaskets, 125.3
 - specifications and standards, 123.1, Table 126.1, Appendix F
 - stresses, 123.1

- maximum allowable internal pressure, 102.2.4
- maximum allowable temperature, 102.2.4
- maximum allowable working pressure, definition, 100.2
- may, definition, 100.2
- mechanical gland joints, 118
- mechanical joint, definition, 100.2
- mechanical strength, 102.4.4
- miniature electronic boiler, 122.1.4(A.1), 122.1.5(C)
- minimum wall thickness, 104.1.2(A)
- miscellaneous systems, 122.1.6
- miter, definition, 100.2
- miters, 104.3.3
- moduli of elasticity, Appendix C
- modulus of elasticity, 119.6.2, 119.6.4
- MSS standards, Table 126.1, Appendix F

- nomenclature, Appendix G
- nominal wall, 104.1.2(A)
- nonboiler external piping, 100.1.2(A)
- noncyclic service, 119.7(A.3)
- nonferrous material limitations, 123.2.7
- nonferrous pipe and tube, 104.1.2(C.3)
- nonintegral type, 121.8.1
- nonmetallic piping materials limitations, 124.9
- nonreclosing pressure relief devices, 107.8.3(C)
- normalizing, definitions, 100.2
- normal operating condition, 102.2.3
- nuts, 108.5.1, Table 112

- occasional loads, 102.2.4
- offsets, 119.5
- oil and flammable liquids, 122.7.1
- operation qualification
 - general, 127.5.1
 - responsibility, 127.5.3(B)
- operator, welding, definitions, 100.2
- other rigid types (fixtures), 121.7.2
- outside screw and yoke, valve, 107.4
- ovality, 104.2.1(B)
- overpressurization, Valve, 107.1(C)
- oxygen cutting, definition, 100.2
- oxygen gouging, definition, 100.2

- packaged equipment, definition, 100.2
- packaged equipment piping, 100.1.3(F)
- peening, 100.2
- penetration, root, definition, 100.2
- PFI standards, Table 126.1, Appendix F
- pilot-operated pressure relief valves, 107.8.3(B)
- pin pressure relief devices/valves, 107.8.3(C)
- pipe
 - attachments, design rules, 104.3.4
 - bends, 104.2.1
 - blanks, 108.2
 - definition, 100.2
 - flange bolting, 108.5, Table 108.5.2
 - flanges, 108.1
 - intersections, design rules, 104.3
 - supporting elements, definition, 100.2
 - supporting elements, design, 121
 - unions, 106.3, 115
- piping joints, 100
- plastic strain, 119.3
- Poisson's ratio, 119.6.3
- postweld heat treatment, 132
 - definition, 100.2
 - definition of thickness governing PWHT, 132.4
 - dissimilar metal welds, 132.2
 - exemptions, 132.3
 - furnace heating, 132.6
 - heating and cooling rates, 132.5
 - local heating, 132.7
 - mandatory requirements, Table 132
 - minimum holding temperature, Table 132
 - minimum holding time, Table 132
- power-actuated pressure-relieving valves, 122.1.7(D.1)
- preheating, 131
 - definition, 100.2
 - dissimilar metals, 131.2
 - temperature, 131.4
- preparation for welding, 127.3
- pressure
 - definition, 100.2
 - entrapped liquids, valve, 107.1(C)
 - gages, 122.1.6
 - reducing valves, 107.1(G), 122.5, 122.14
 - relief piping, 122.6
 - temperature ratings, 102.2
 - waves, 101.5.1
- pressure-relieving devices, 107.8.1, 107.8.3(C)
- pressure-relieving valves, 107.8.1, 107.8.2, 107.8.3(B)
- pressure tests
 - general requirements, 137.1
 - maximum stress during test, 137.1.4
 - personnel protection, 137.1.3
 - subassemblies, 137.1.1
 - temperature of test medium, 137.1.2
 - testing schedule, 137.1.5
 - hydrostatic, 137.4
 - equipment check, 137.4.4
 - material, 137.4.1
 - required pressure, 137.4.5
 - test medium, 137.4.3
 - venting, 137.4.2
- initial service, 137.7
- mass-spectrometer and halide, 137.6
- pneumatic, 137.5
 - equipment check, 137.5.3
 - general, 137.5.1
 - preliminary test, 137.5.4

- required pressure, 137.5.5
- test medium, 137.5.2
- preparation for test, 137.2
 - expansion joints, 137.2.3
 - flanged joints containing blanks, 137.2.5
 - isolation of piping and equipment, 137.2.4
 - joint exposure, 137.2.1
 - temporary supports, 137.2.2
 - test medium expansion, 137.2.6
- retesting, 137.8
- specific piping systems, 137.3
 - boiler external piping, 137.3.1
 - nonboiler external piping, 137.3.2
- procedures, welding, definitions, 100.2
- proprietary joints, 118
- pump discharge piping, 122.13
- pump suction piping, 122.12

- qualification, brazing, 128.5
- qualification, welding, 127.5
 - procedure responsibility, 127.5.3(A)
 - responsibility, 127.5.2
 - welder and welding operation responsibility, 127.5.3(B)
- quality control requirements for boiler external piping (BEP), App. J

- ratings
 - at transitions, 102.2.5
 - variation from normal operation, 102.2.4
- records, brazing, 128.6
- records, welding, 127.6
- reducers, 104.6
- reinforcement
 - branch connections, 104.3.1(D)
 - of weld, definitions, 100.2
 - of welds, Table 127.4.2
 - zone, 104.3.1(D.2.4)
- relief valves, 107.8.3(B)
- repair, weld defects, 127.4.11
- restraints, 119.5, 119.7.3
- reversed stress, 119.2
- ring, backing, definition, 100.2
- rolled joints, 113
- rolled pipe, definition, 100.2
- root opening, definitions, 100.2
- rupture disks, 107.8.3(C)

- safety and safety-relief valves, 107.8.3, 122.1.7(D.1), 122.8.1(D)
- sampling piping, 122.3.5(C)
- scope, 100.1
- seal weld
 - definition, 100.2
 - welds, 111.5
 - thread joints, 127.4.5, 135.5.2
- seamless pipe, definition, 100.2
- self-springing, 119.2
- semiautomatic arc welding, definition, 100.2
- shall, definition, 100.2
- shielded metal arc welding, definition, 100.2
- shock, 117.3(C)
- should, definition, 100.2
- size of weld, definition, 100.2
- slag inclusion, definition, 100.2
- sleeve coupled joints, 118
- snow and ice load, 101.6.1
- socket — type joints, 117
- socket welds, 111.3
 - assembly, 127.3(E)
- soldering
 - definition, 100.2
 - filler metal, 128.2.1
 - flux, 128.2.2
 - flux removal, 128.4.3
 - heating, 128.4.2
 - material, 128.2
 - preparation, 128.3
 - procedure, 128.1.2
 - soft soldered joints, 117.2, 117.3
 - soldered joints, 117
- spacing, welding, 127.3(D)
- special safety provisions — instrument, control, and sampling piping, 122.3.7
- specifications, valve, 107.1(A)
- specifications and standards organizations, Table 126.1, Appendix F
- specific piping systems, design, 122
- springs, 121.6
- spring-loaded nonreclosing pressure relief devices, 107.8.3(C)
- stamping, 133
- standards
 - acceptable, 123.1, Table 126.1, Appendix F
 - valve, 107.1(A)
- standard welding procedure specifications, 127.5.4
- statically cast pipe, definition, 100.2
- steam distribution systems, 122.14
- steam hammer, 101.5.1
- steam jet cooling systems, 100.1.2(D)
- steam piping, 122.1.2
- steam retention, 107.1(D)
- steam stop valves, 122.1.7(A)
- steam trap piping, 122.11
- steel
 - unassigned stress values, 102.3.1(D)
 - unknown specification, 102.3.1(C)
- steel casting quality factor, 102.4.6
- steel limitations
 - carbon content, 124.2(D)
 - graphitization, 124.2(A) and (B)
 - welding, 124.2(C)

- stem threads, valve, 107.4
- strain, 119
 - concentration, 119.3
 - distribution, 119.3
 - range, 119.2
- stress, 119.6.4
 - analysis, 119.7
 - bearing, 121.2(F)
 - compressive, 121.2(E)
 - concentration, 119.3
 - external pressure, 102.3.2(B)
 - intensification, 119.7.1(D)
 - factors, 111.2.1, 119.7.3
 - internal pressure, 102.3.2(A)
 - limitations on materials, 123.2, Appendix A
 - limits, 102.3
 - occasional loads, 102.3.3
 - longitudinal pressure, 102.3.2(D)
 - raisers, 119.3
 - range, 102.3.2(C), 119.2
 - reduction, 119.2
 - relaxation, 119.2
 - relieving, definition, 100.2
 - shear, 121.2(D)
 - tension, 121.2
- structural attachments, 121.8
 - definitions, 100.2
- submerged arc welding, definitions, 100.2
- supports, design, 119.5, 121
 - instrument, control, and sampling piping, 122.3.8
- surface condition, girth butt welds, 127.4.2(C)
- surface preparation, brazing, 128.3.1
- sway braces, 121.7.5
- swedging, 129.2
- swivel joints, 101.7.2, 119.5

- tack weld, definitions, 100.2
- tack welds, 127.4.1(C)
- take-off connections, 122.3.2
- temperature, 101.3.1
 - graphitization, 124.2
 - limitations
 - cast iron, 124.4
 - ductile (nodular) iron, 124.6
 - low, 124.1.2, Appendix VIII
 - malleable iron, 124.5
 - stress values, 124.1
- temporary piping, 122.10
- terminal points, boiler external piping, 100.1.2(A)
- testing — instrument, control, and sampling piping, 122.3.9(A)
- test load, 101.6.3
- thermal contraction, 119.1
- thermal expansion, 101.7, 119, Appendix B
 - analysis, 119.7.1
 - range, 119.6.1
- threaded brass pipe, 104.1.2(C.2)
- threaded connections
 - aluminum pipe, 124.7(C)
- threaded copper pipe, 104.1.2(C.2)
- threaded joints, 114
 - lubricant, 135.5.1
 - seal welded, 135.5.2
- threaded piping, 135.5
- threaded steel pipe, 104.1.2(C.1)
- threading and grooving allowance, 102.4.2
- threads, valve stem, 107.4
- throat of fillet weld, definitions, 100.2
- T-number, 124.1.2, Appendix VIII
- toe of weld, definitions, 100.2
- toughness, 124.1.2
- toxic fluids, 117.3(A)
- transients
 - pressure, 102.2.4
 - temperature, 102.2.4
- transitions, local pressure, 102.2.5
- transitions, O.D., 127.4.2(B)
- trap discharge piping, 122.11.2
- treatment, heat, definitions, 100.2
- tungsten electrode, definitions, 100.2

- undercut, definitions, 100.2
- undercuts, girth butt welds, 127.4.2(C.3)
- unit expansion, 119.6.1
- upsetting, pipe ends, 129.2

- vacuum, 101.4.1
- valves, 107
 - blowoff, 122.1.7(C)
 - bonnet joint, 107.5
 - bypasses, 107.6
 - diaphragm, 107.1(F)
 - drains, 107.1(C), 122.1.5
 - ends, 107.3
 - feedwater, 122.1.7(B)
 - and fittings, 122.1.7
 - flanged ends, 107.3
 - general, 107.1
 - marking, 107.2
 - miniature boilers, 122.1.7(A.1.B)
 - noncomplying designs, 107.1(B)
 - pressure regulator, 107.1(G)
 - pressure-relieving, 107.8.1, 107.8.2, 107.8.3(B)
 - relief, 107.8.3(B)
 - safety and safety-relief, 107.8.3, 122.1.7(D.1), 122.8.1(D)
 - specifications, 107.1(A)
 - standards, 107.1(A)
 - steam stop, 122.1.7(A)
 - threaded ends, 107.3
 - welding ends, 107.3
- variable supports, 121.7.3

- variations from normal operation, 102.2.4
- vibration, 101.5.4, 117.3(C)

- washers, 108.5.1
- water
 - columns, 122.1.6
 - hammer, 101.5.1
 - level indicators, 122.1.6
- weight effects, 101.6
- weld
 - concavity, 127.4.2(C.5)
 - definitions, 100.2
- weld, fillet, definition, 100.2
- weld, seal, definition, 100.2
- weld, tack, definition, 100.2
- weld defect repair, 127.4.11
- welded branch connections, 127.4.8
 - construction, carbon limitation, 124.2(C)
- welded joints, 111
- welder, definitions, 100.2
- welding, 127
 - arc, definition, 100.2
 - automatic, definition, 100.2
 - braze, definition, 100.2
 - end transition, Fig. 127.4.2
 - filler metal, 127.2.1
 - general, 127.1
 - gun, definition, 100.2
 - low energy capacitor discharge,
 - definition, 100.2
 - manual, definition, 100.2
 - material, 127.2
 - operator, definitions, 100.2
 - preparation, 127.3
 - procedure, 127.4
 - process qualification, 127.1.1
 - records, 127.6
 - responsibility, 127.5.2
- weld joint efficiency factor, longitudinal, 102.4.3
- weldment, definitions, 100.2
- weld reinforcement heights, Table 127.4.2
- weld surface preparation, 127.4.2(C)
- wind loadings, 101.5.2
- WPS, qualification, 127.5.1

INTENTIONALLY LEFT BLANK

ASME CODE FOR PRESSURE PIPING, B31

Power Piping	B31.1-2016
Process Piping	B31.3-2014
Tuberías de Proceso	B31.3-2010
Pipeline Transportation Systems for Liquids and Slurries.....	B31.4-2016
Refrigeration Piping and Heat Transfer Components.....	B31.5-2016
Gas Transmission and Distribution Piping Systems	B31.8-2014
Managing System Integrity of Gas Pipelines	B31.8S-2014
Gestión de Integridad de Sistemas de Gasoductos	B31.8S-2010
Building Services Piping	B31.9-2014
Hydrogen Piping and Pipelines.....	B31.12-2014
Standard for the Seismic Design and Retrofit of Above-Ground Piping Systems	B31E-2008
Manual for Determining the Remaining Strength of Corroded Pipelines: Supplement to ASME B31 Code for Pressure Piping.	B31G-2012
Manual para la determinación de la resistencia remanente de tuberías corroídas	B31G-2012
Standard Test Method for Determining Stress Intensification Factors (<i>i</i> -Factors) for Metallic Piping Components	B31J-2008 (R2013)
Método de prueba estándar para determinar factores de intensificación de esfuerzo (Factores <i>i</i>) para componentes de tuberías metálicas	B31J-2008 (R2013)
Pipeline Personnel Qualification.....	B31Q-2014
Calificación del personal de líneas de tuberías.....	B31Q-2010
Standard Toughness Requirements for Piping.....	B31T-2010

The ASME Publications Catalog shows a complete list of all the Standards published by the Society. For a complimentary catalog, or the latest information about our publications, call 1-800-THE-ASME (1-800-843-2763).

ASME Services

ASME is committed to developing and delivering technical information. At ASME's Customer Care, we make every effort to answer your questions and expedite your orders. Our representatives are ready to assist you in the following areas:

ASME Press
Codes & Standards
Credit Card Orders
IMEchE Publications
Meetings & Conferences
Member Dues Status

Member Services & Benefits
Other ASME Programs
Payment Inquiries
Professional Development
Short Courses
Publications

Public Information
Self-Study Courses
Shipping Information
Subscriptions/Journals/Magazines
Symposia Volumes
Technical Papers

How can you reach us? It's easier than ever!

There are four options for making inquiries* or placing orders. Simply mail, phone, fax, or E-mail us and a Customer Care representative will handle your request.

Mail
ASME
150 Clove Road, 6th Floor
Little Falls, New Jersey
07424-2138

Call Toll Free
US & Canada: 800-THE-ASME
(800-843-2763)
Mexico: 95-800-THE-ASME
(95-800-843-2763)

Fax—24 hours
973-882-1717
973-882-5155

E-Mail—24 hours
customer care@asme.org

* Customer Care staff are not permitted to answer inquiries about the technical content of this code or standard. Information as to whether or not technical inquiries are issued to this code or standard is shown on the copyright page. All technical inquiries must be submitted in writing to the staff secretary. Additional procedures for inquiries may be listed within.

ASME B31.1-2016

ISBN 978-0-7918-7072-3



9 7 8 0 7 9 1 8 7 0 7 2 3



A 0 5 8 1 6